

THIS DRAWING IS THE PROPERTY OF SQ SPADINA QUEEN TRIDEL. IT IS TO BE USED FOR THE PROJECT AND SITE SPECIFICALLY IDENTIFIED HEREIN. IT IS NOT TO BE REPRODUCED, COPIED, OR TRANSMITTED IN ANY FORM OR BY ANY MEANS, ELECTRONIC OR MECHANICAL, INCLUDING PHOTOCOPYING, RECORDING, OR BY ANY INFORMATION STORAGE AND RETRIEVAL SYSTEM, WITHOUT THE WRITTEN PERMISSION OF SQ SPADINA QUEEN TRIDEL. THE CONTRACTOR SHALL BE RESPONSIBLE FOR OBTAINING ALL NECESSARY PERMITS AND APPROVALS FROM THE APPLICABLE AUTHORITIES. THE CONTRACTOR SHALL BE RESPONSIBLE FOR OBTAINING ALL NECESSARY PERMITS AND APPROVALS FROM THE APPLICABLE AUTHORITIES. THE CONTRACTOR SHALL BE RESPONSIBLE FOR OBTAINING ALL NECESSARY PERMITS AND APPROVALS FROM THE APPLICABLE AUTHORITIES.

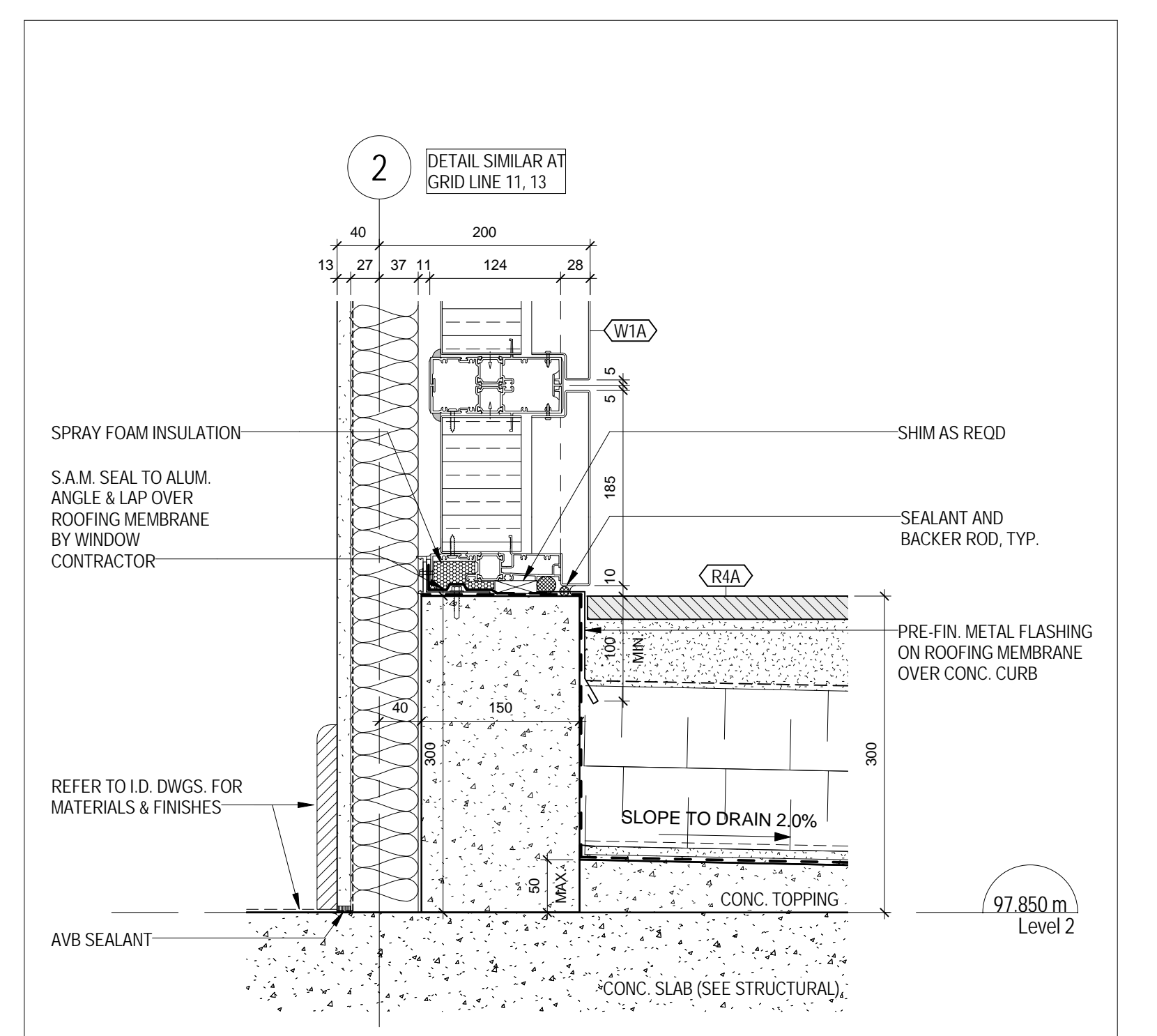

METRIC SCALE DRAWING
FIRST FLOOR ELEV. +93.60m

No.	ISSUED/REVISION FOR	DATE
1	Issued for Permit	2014-06-22
2	Issued for Tender	2014-08-26
3	Issued for Tender	2014-09-22
4	Issued for Tender	2015-05-05
5	Issued for Special Tender	2015-08-19



12 TYPICAL WINDOW WALL AT 2F TERRACE CONC. CURB
A 613 1:5

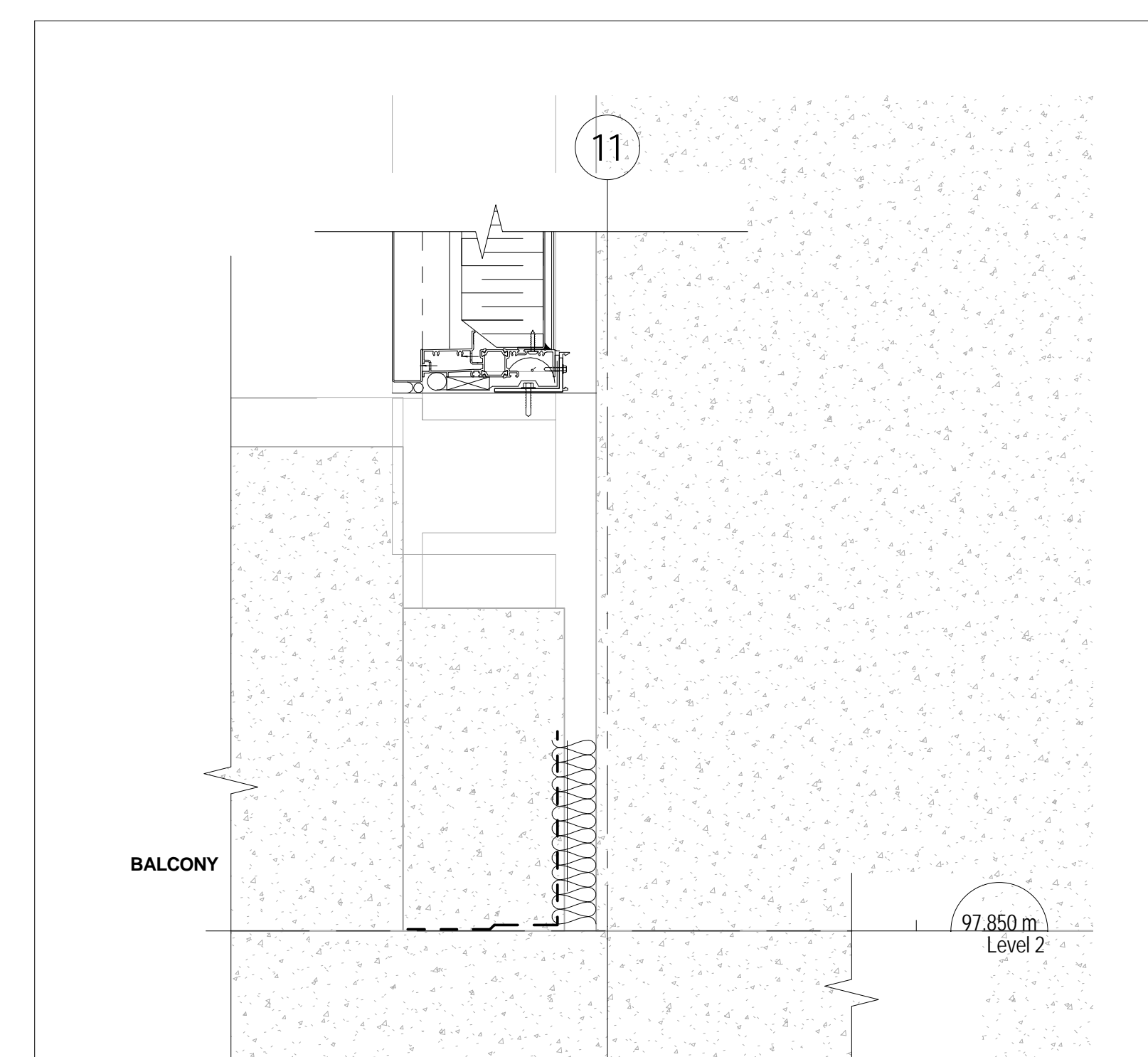

11 TYPICAL TERRACE PARAPET TO BUILDING CORNER
A 613 1:5

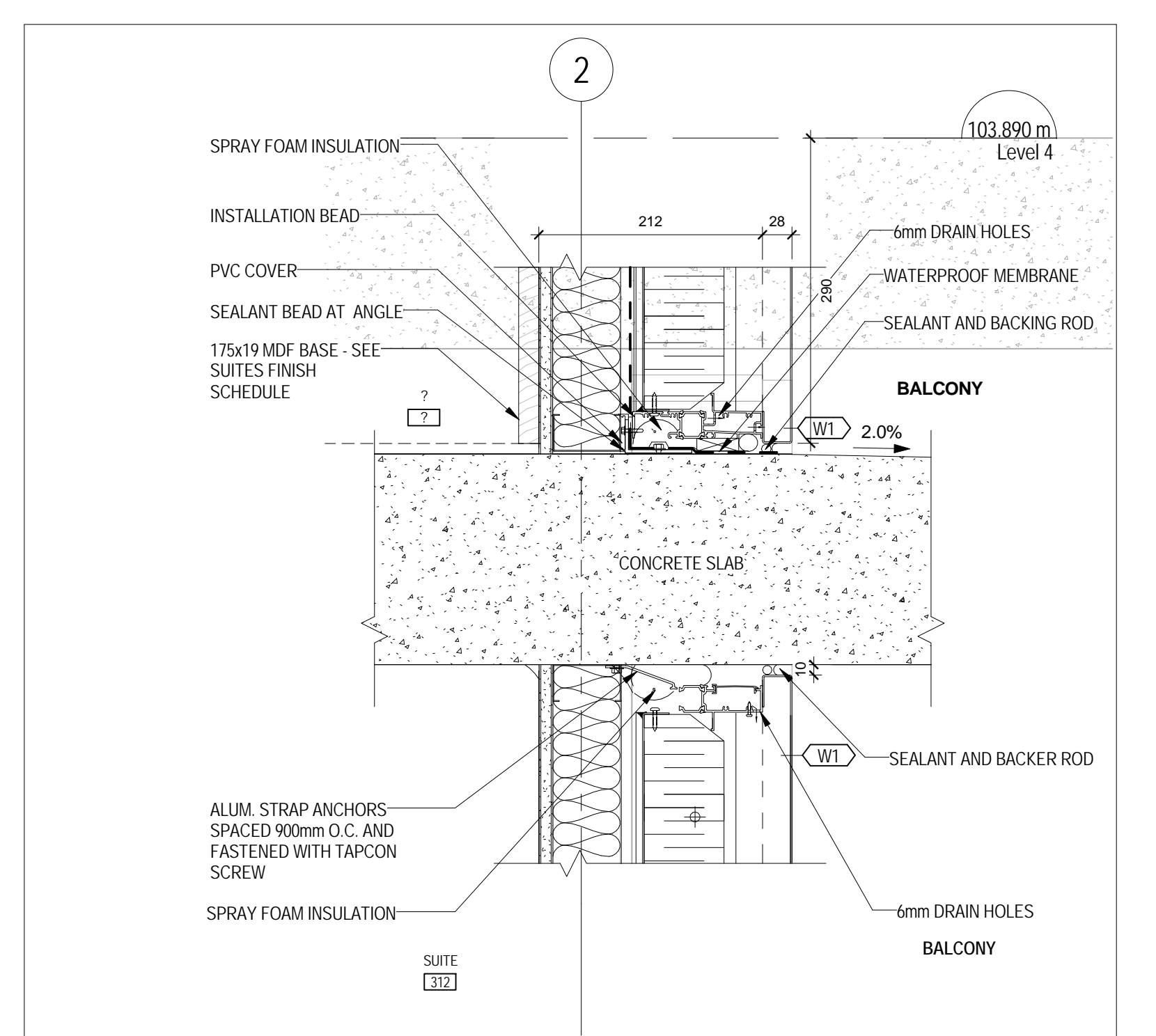

3 TYPICAL PROJECTED PANEL AT STRUCTURE
A 613 1:5

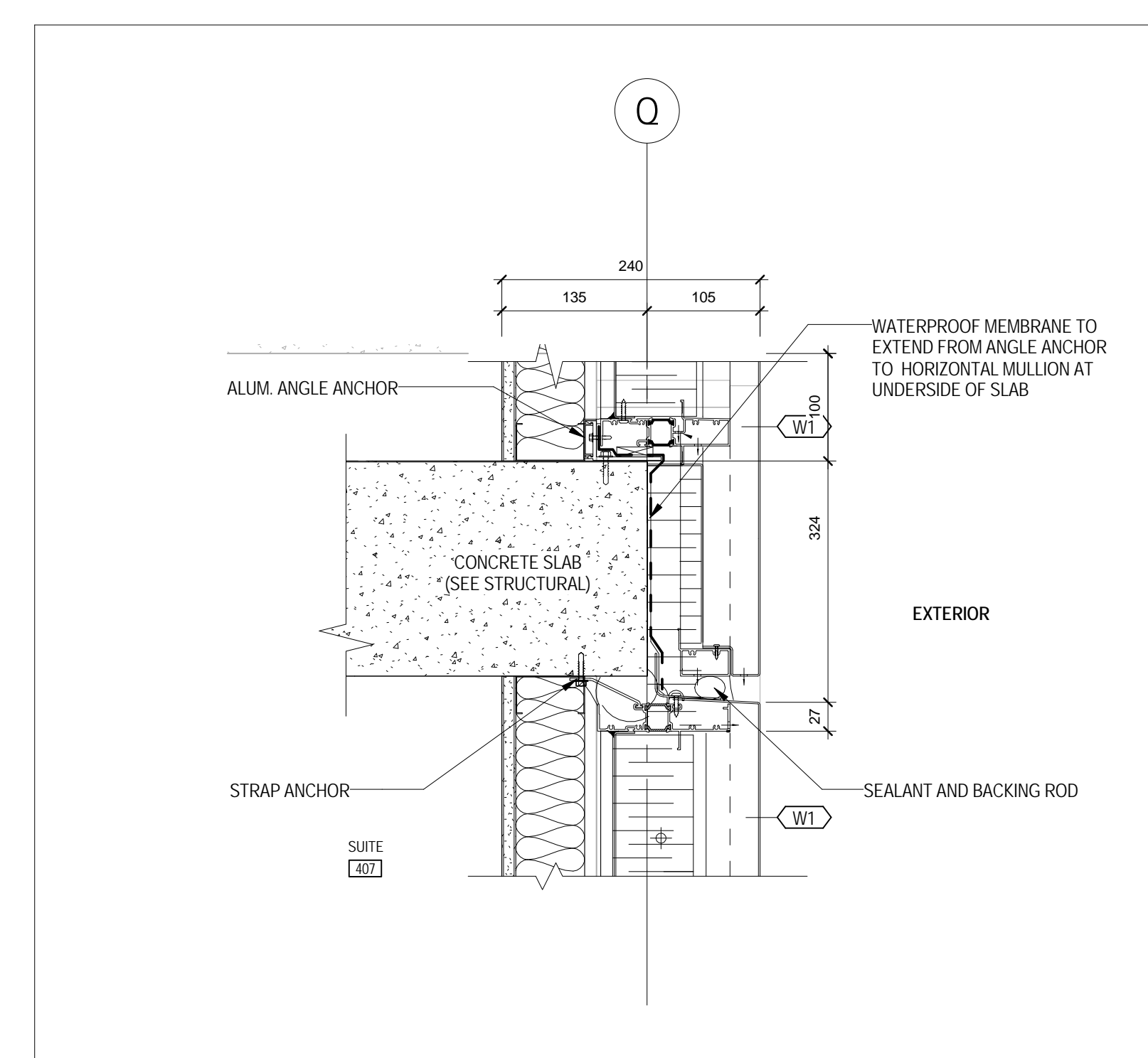

6 TYPICAL BYPASS - METAL PANEL TO METAL PANEL
A 613 1:5

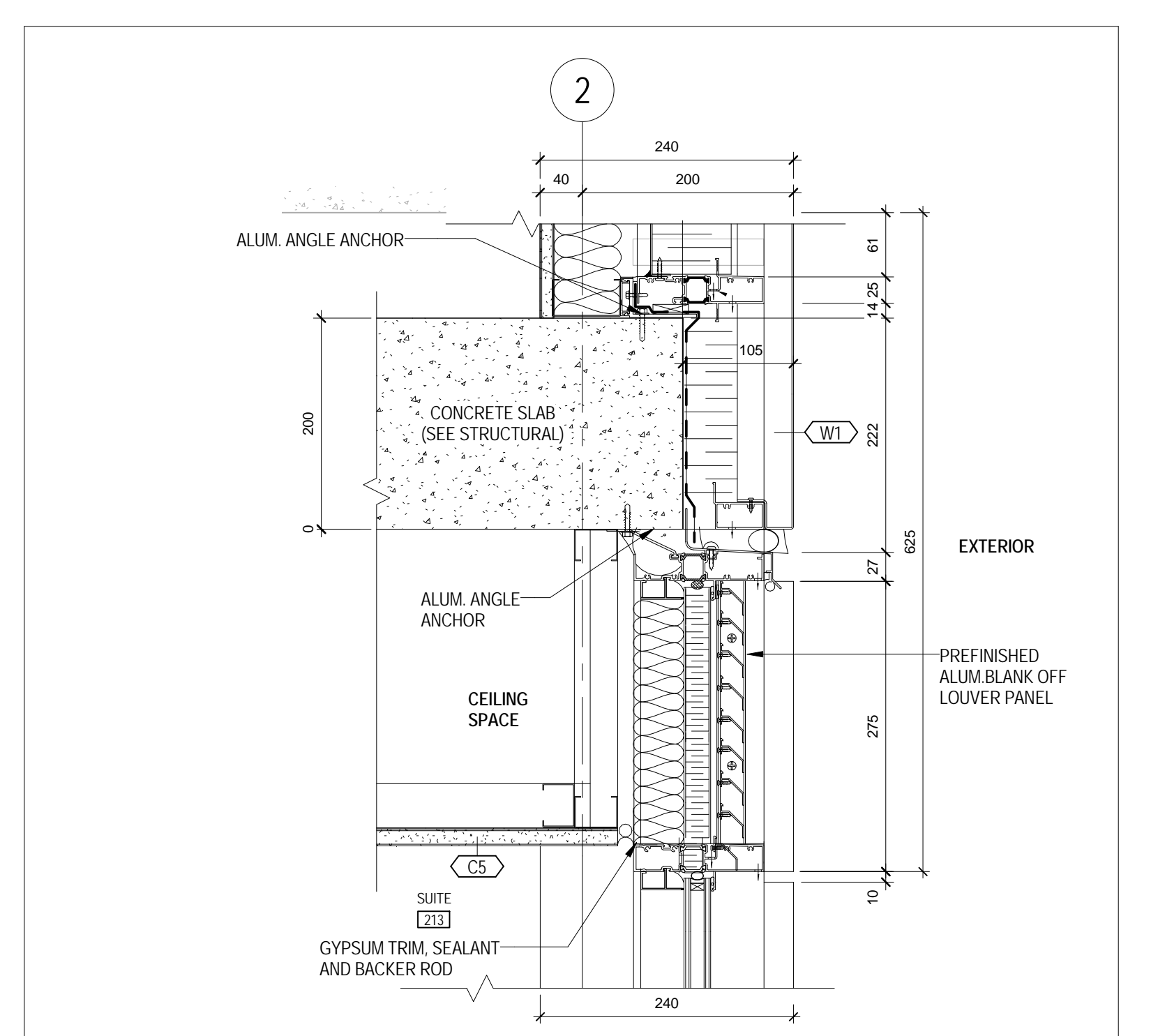

2 TYPICAL LOUVER TO METAL PANEL
A 613 1:5

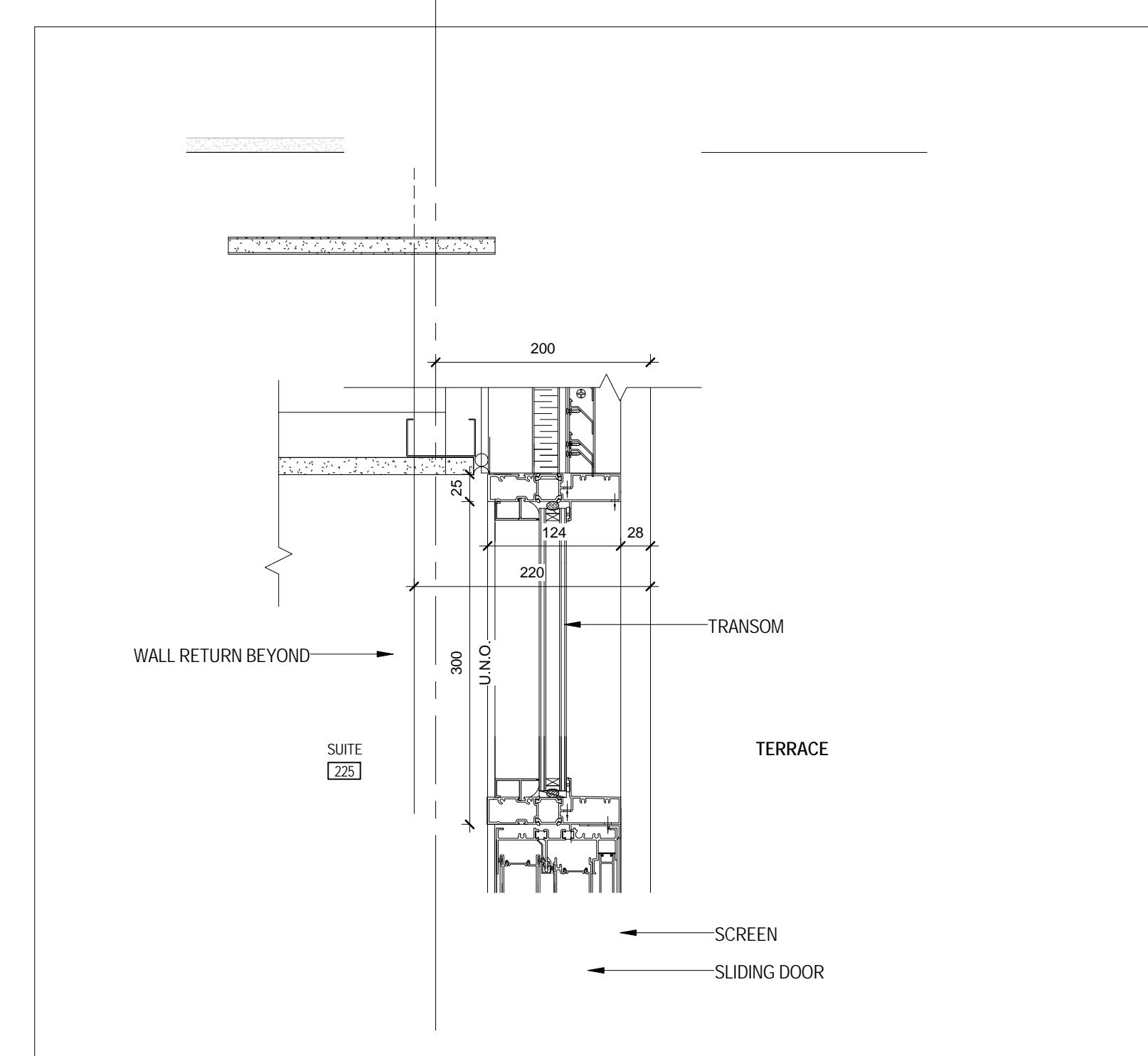

5 TYPICAL SLIDING DOOR HEAD
A 613 1:5

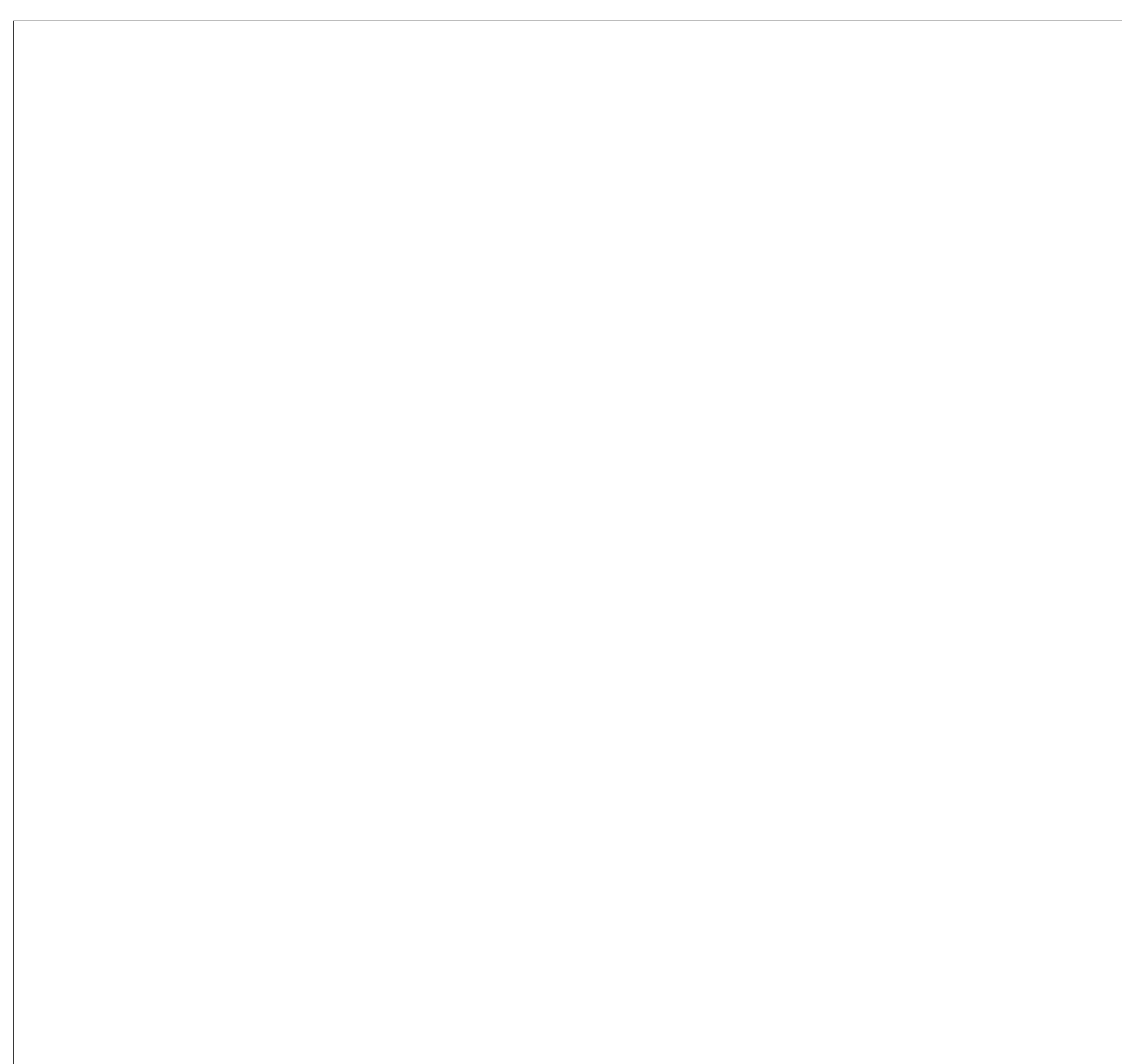

8 TYPICAL ACTIVE LOUVER
A 613 1:5

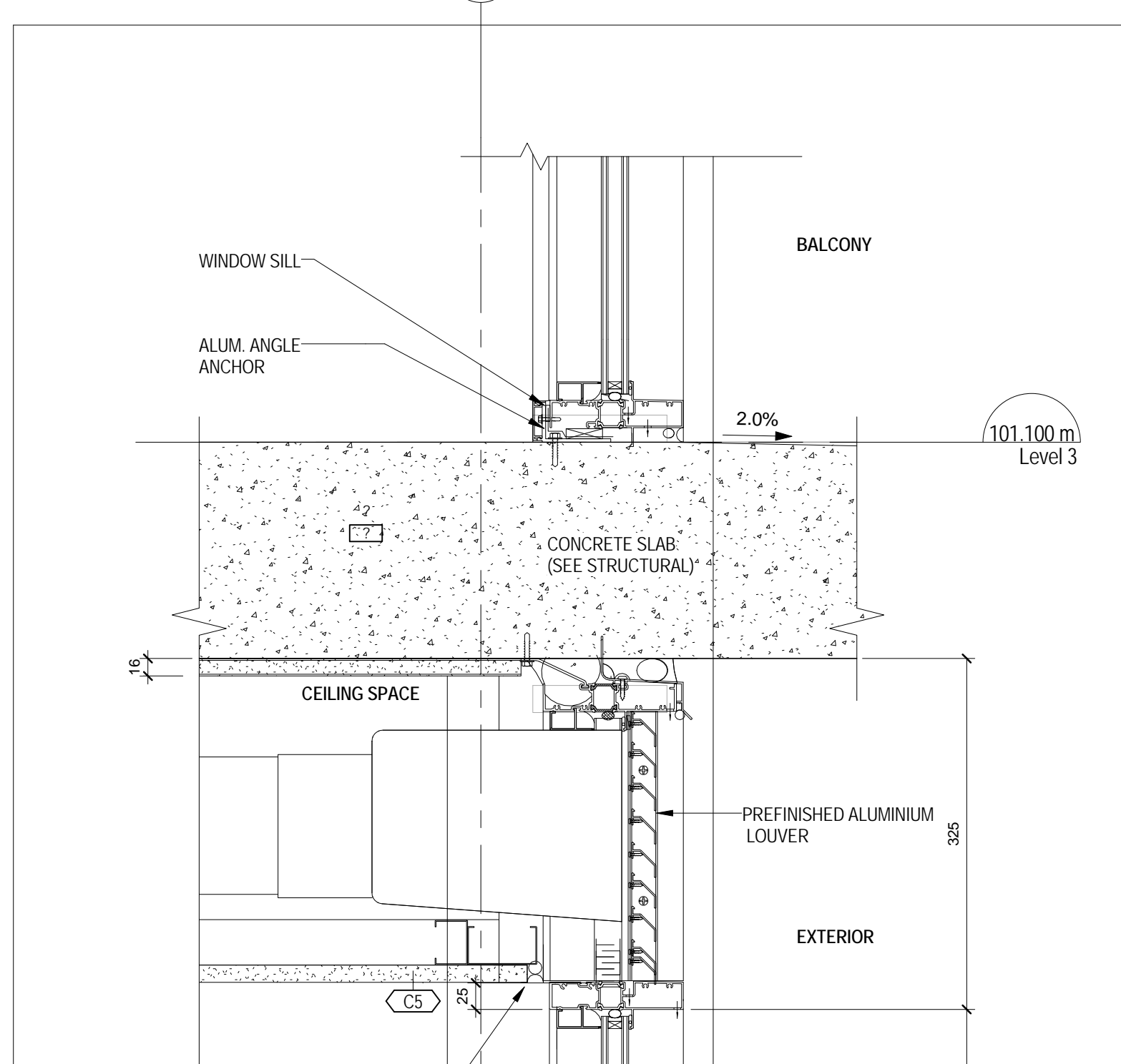

10 TYPICAL BLANK OFF LOUVER
A 613 1:5

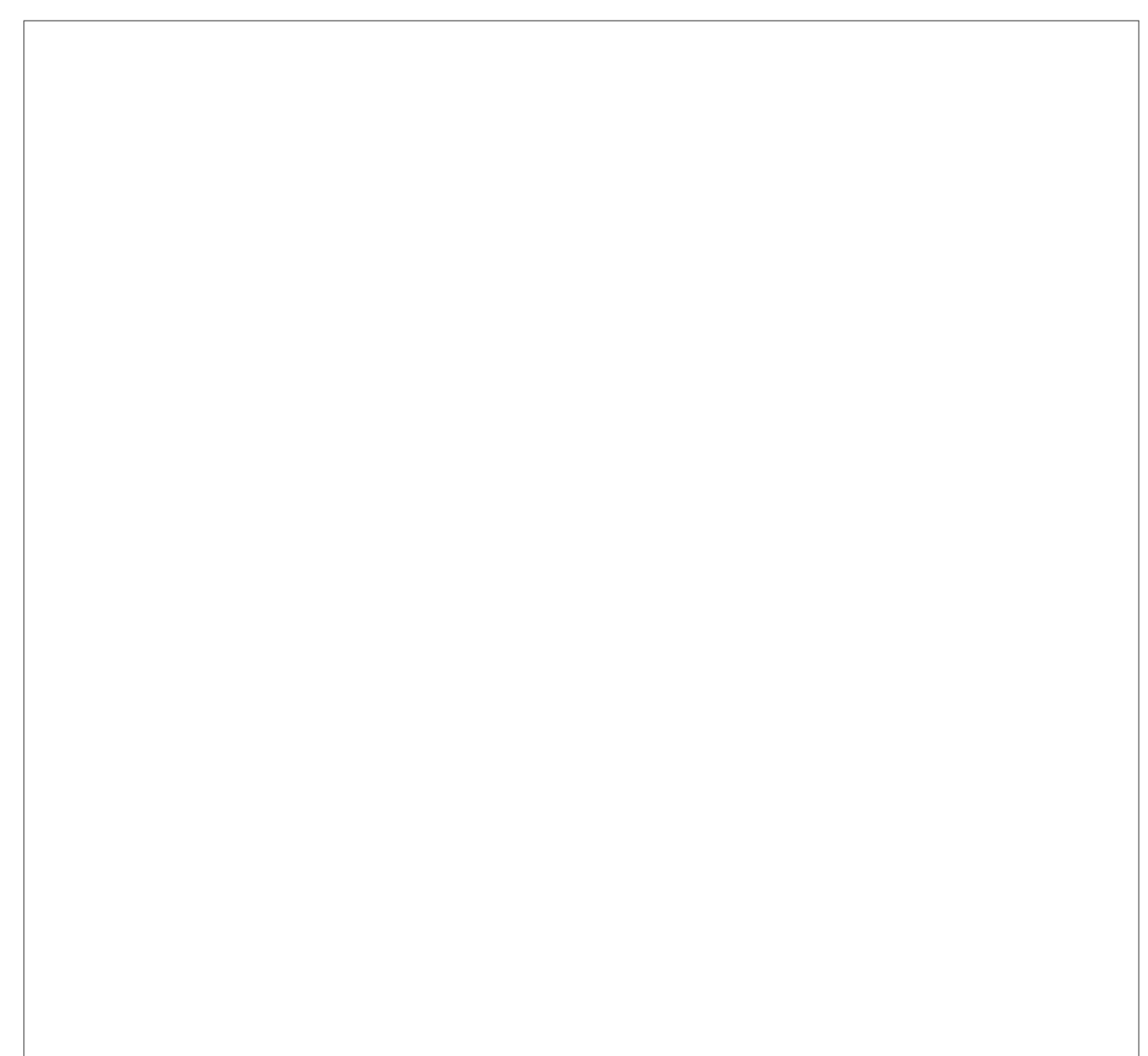

10 TYPICAL BLANK OFF LOUVER
A 613 1:5

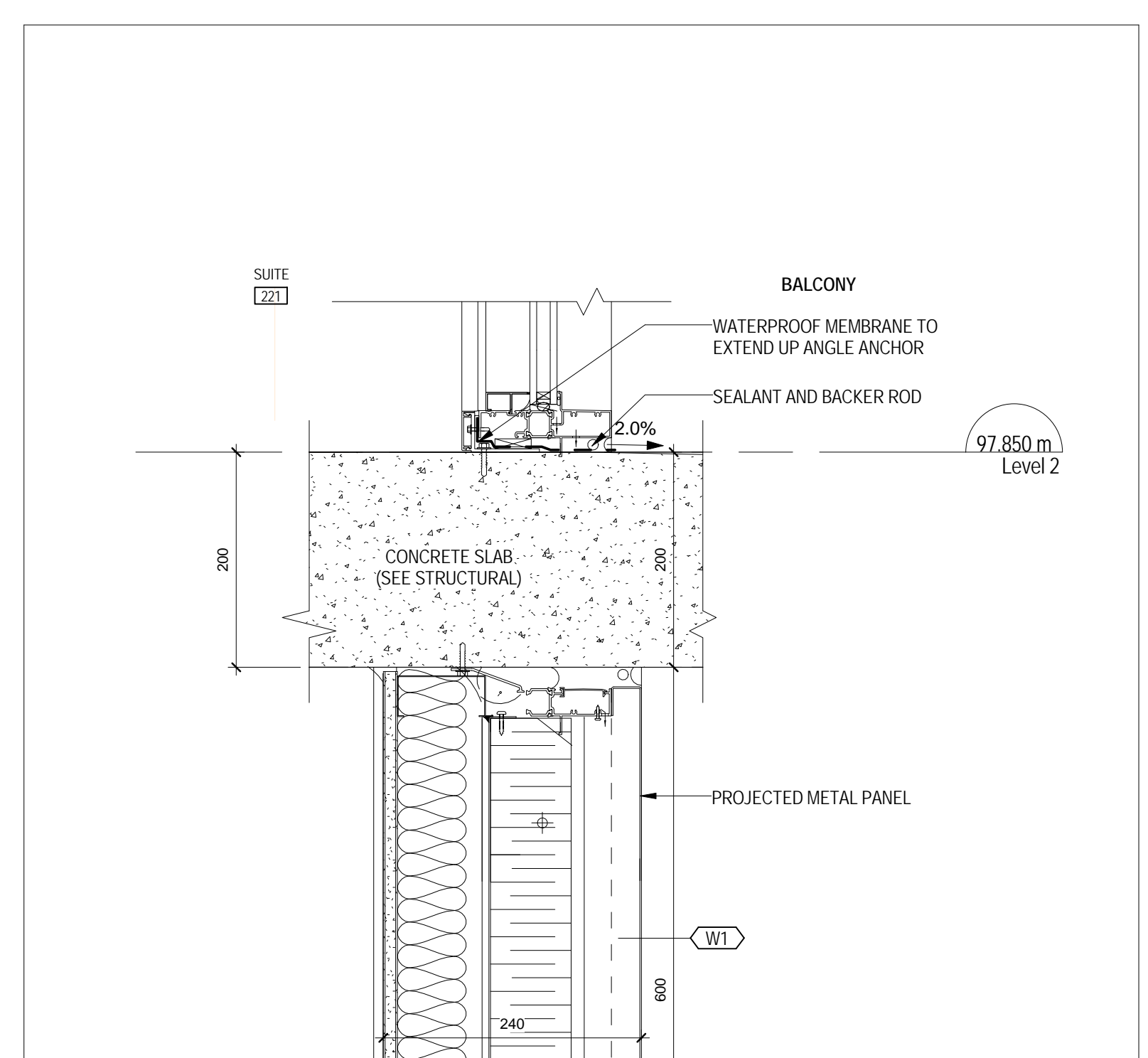

10 TYPICAL BLANK OFF LOUVER
A 613 1:5

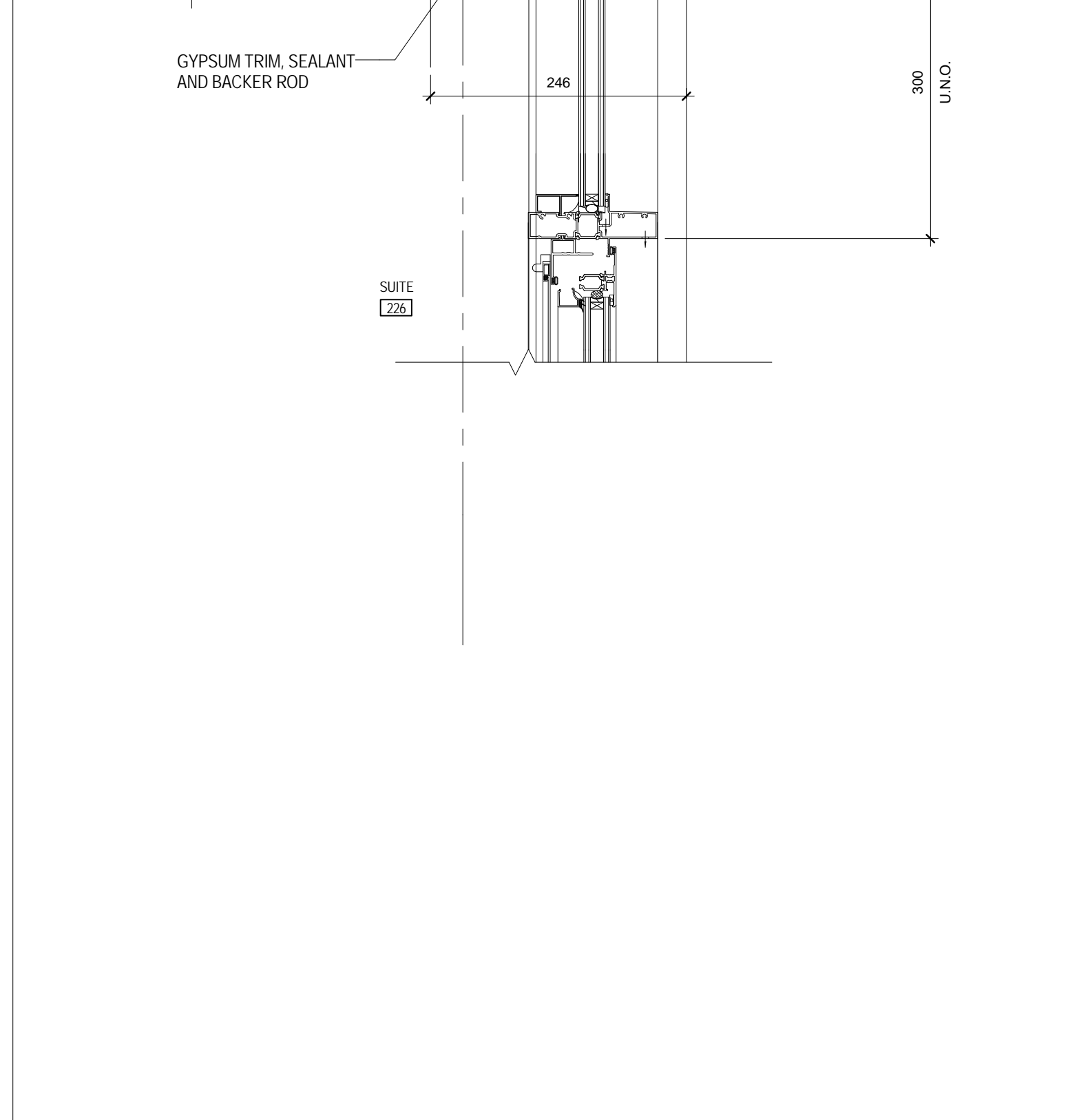

7 TYPICAL DOOR SILL AT BALCONY
A 613 1:5

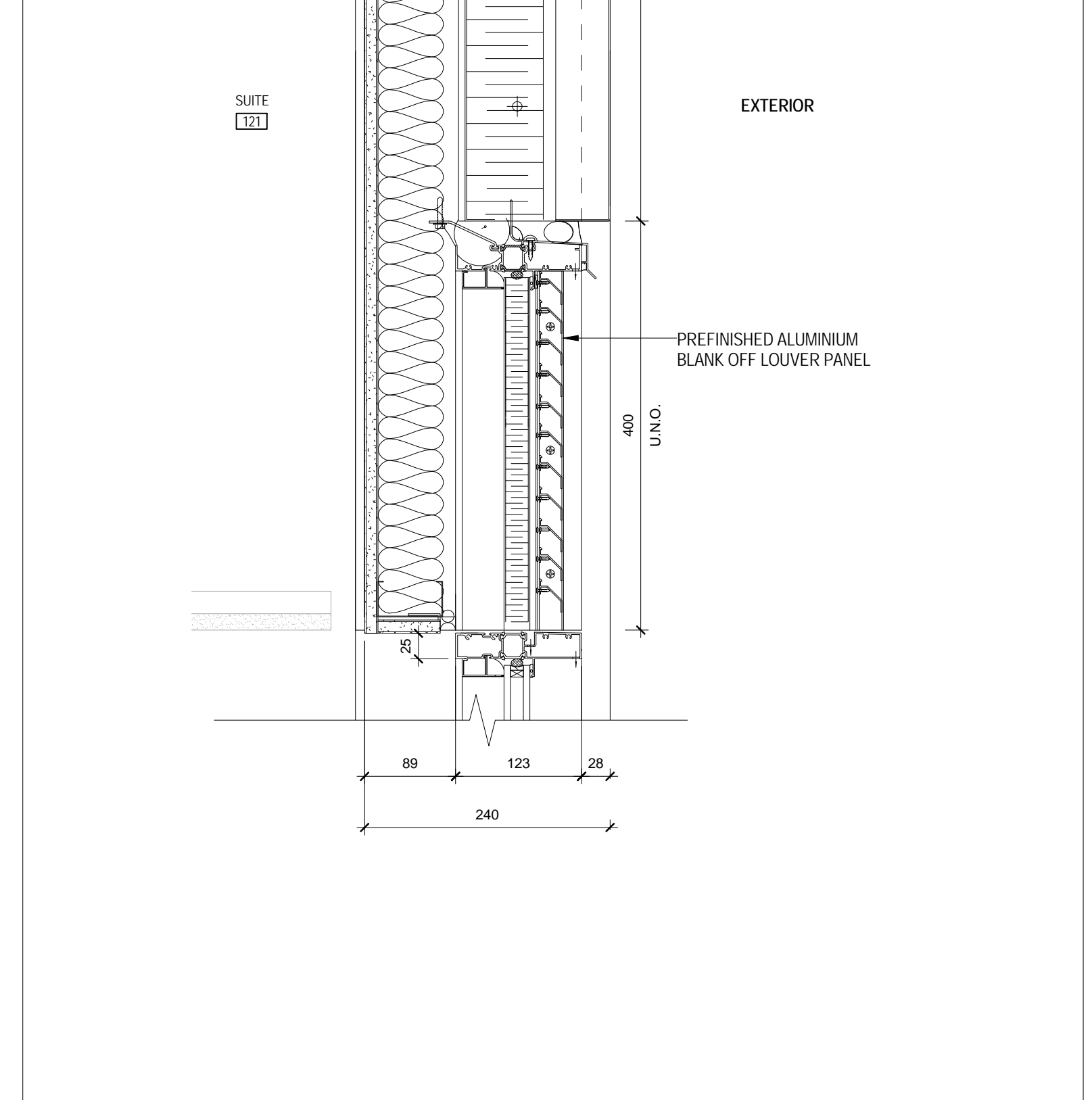

9 TYPICAL AWNING VENT
A 613 1:5

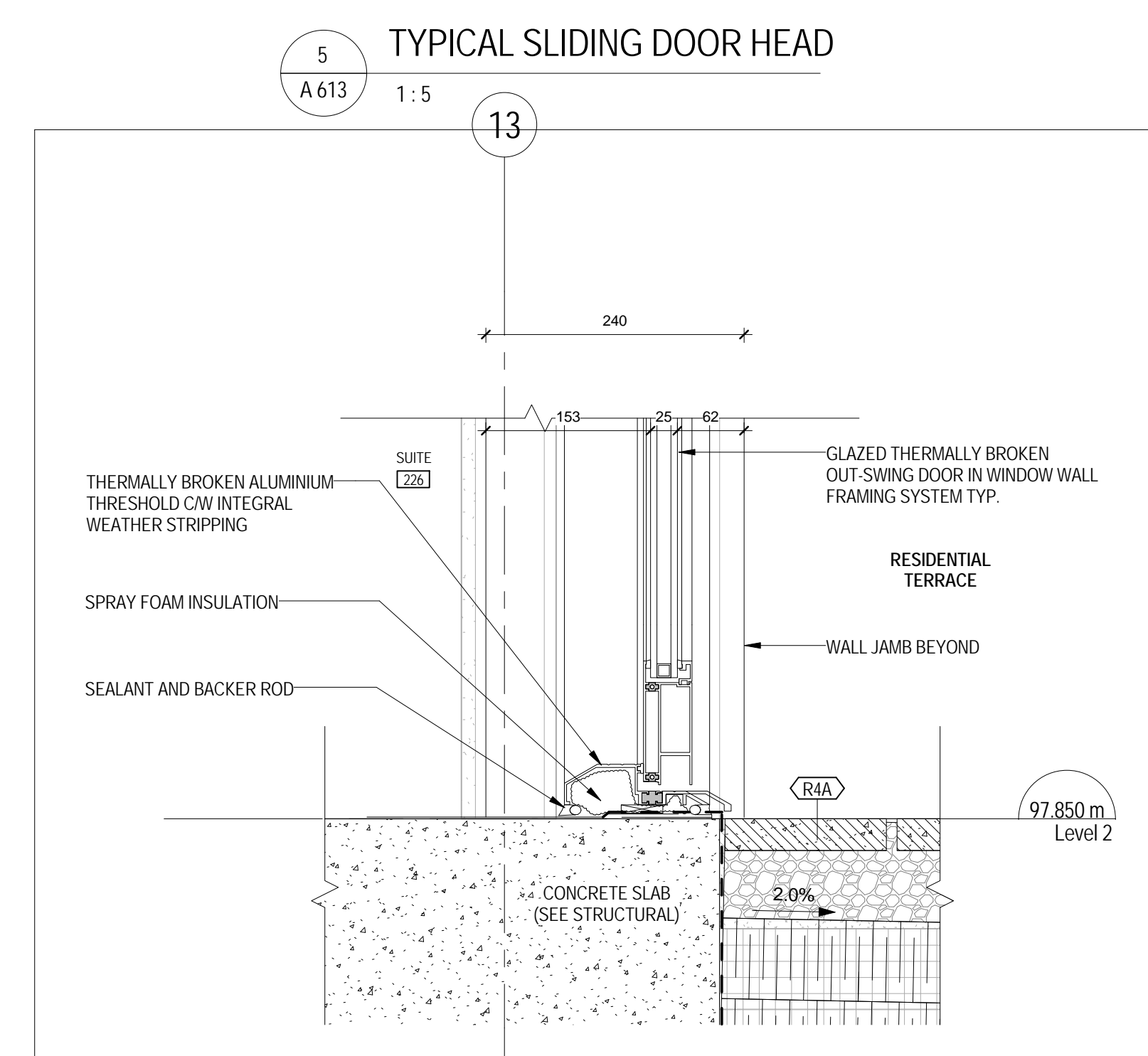

4 TYPICAL SWING DOOR AT SUITE TERRACE
A 613 1:5

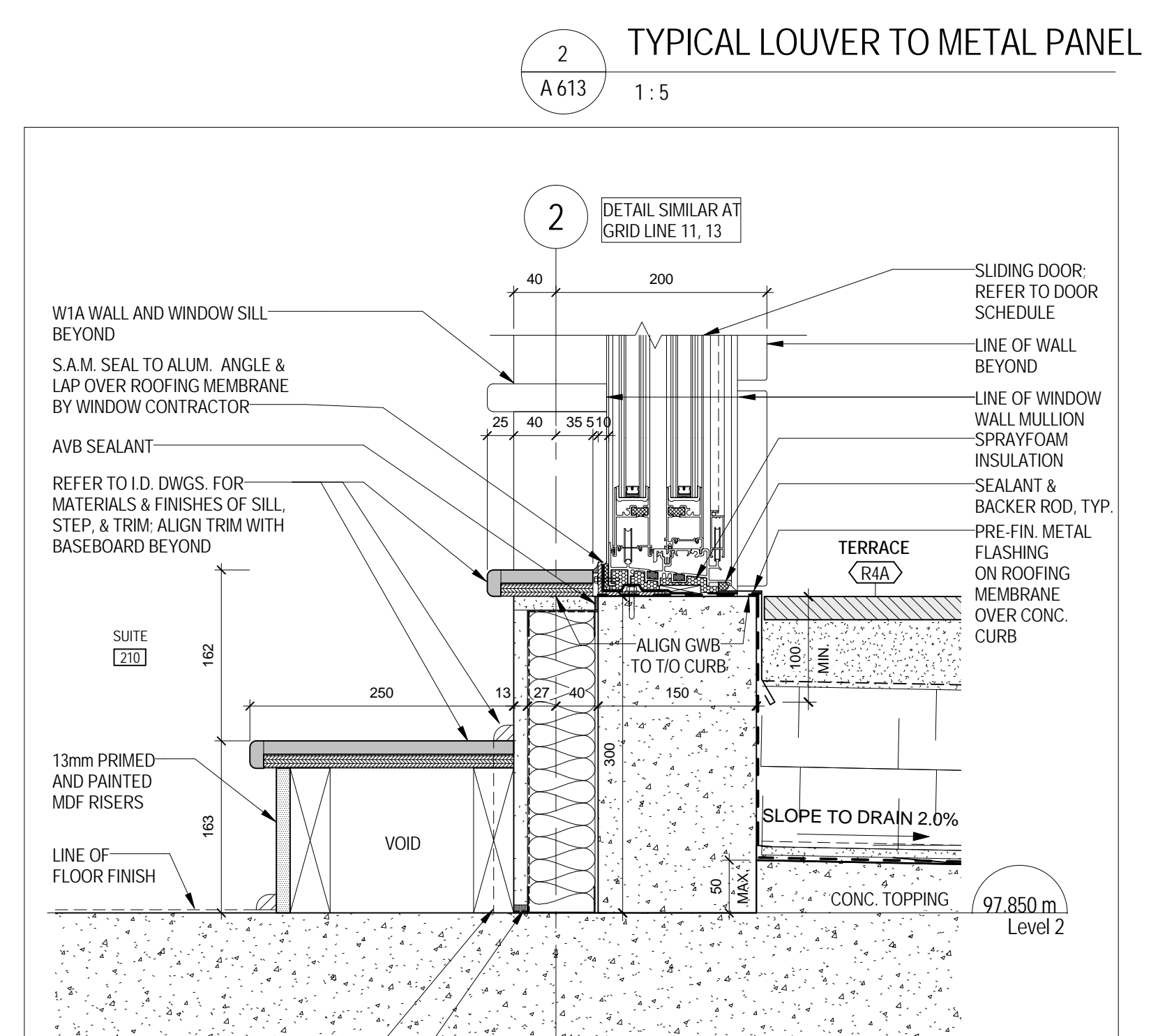

1 TYPICAL SLIDING DOOR AT 2F RAISED TERRACE
A 613 1:5

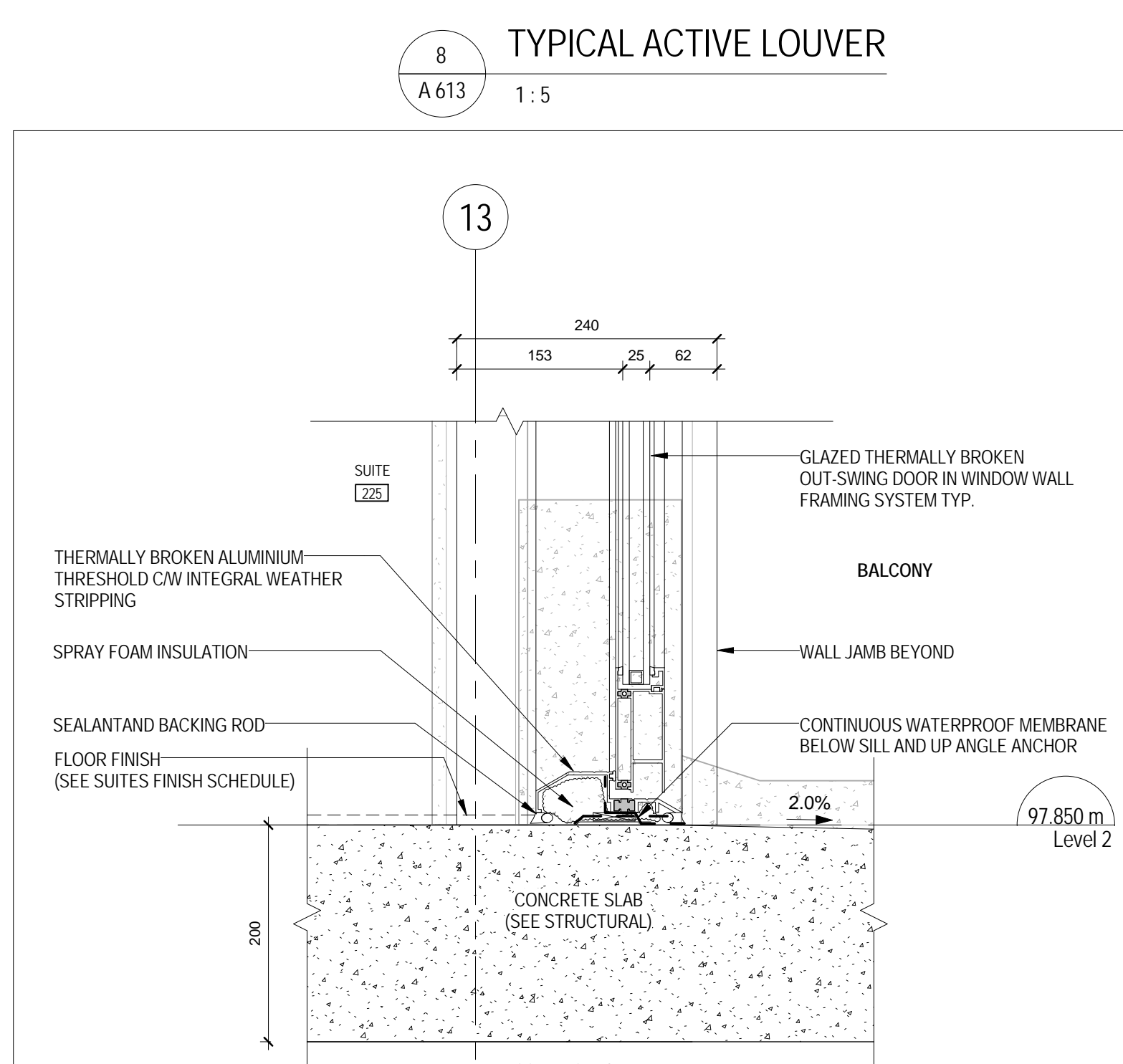

7 TYPICAL DOOR SILL AT BALCONY
A 613 1:5

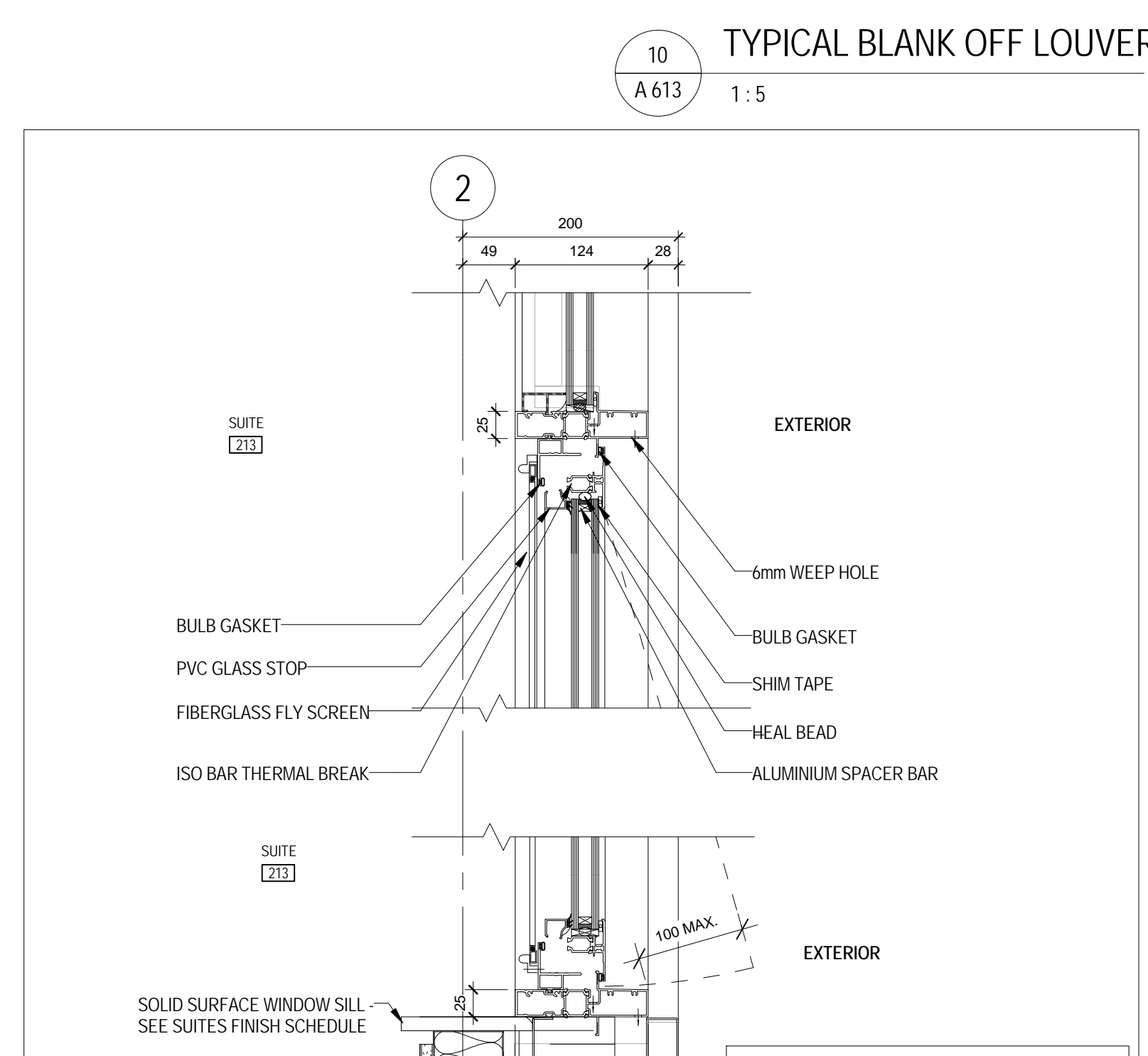

9 TYPICAL AWNING VENT
A 613 1:5

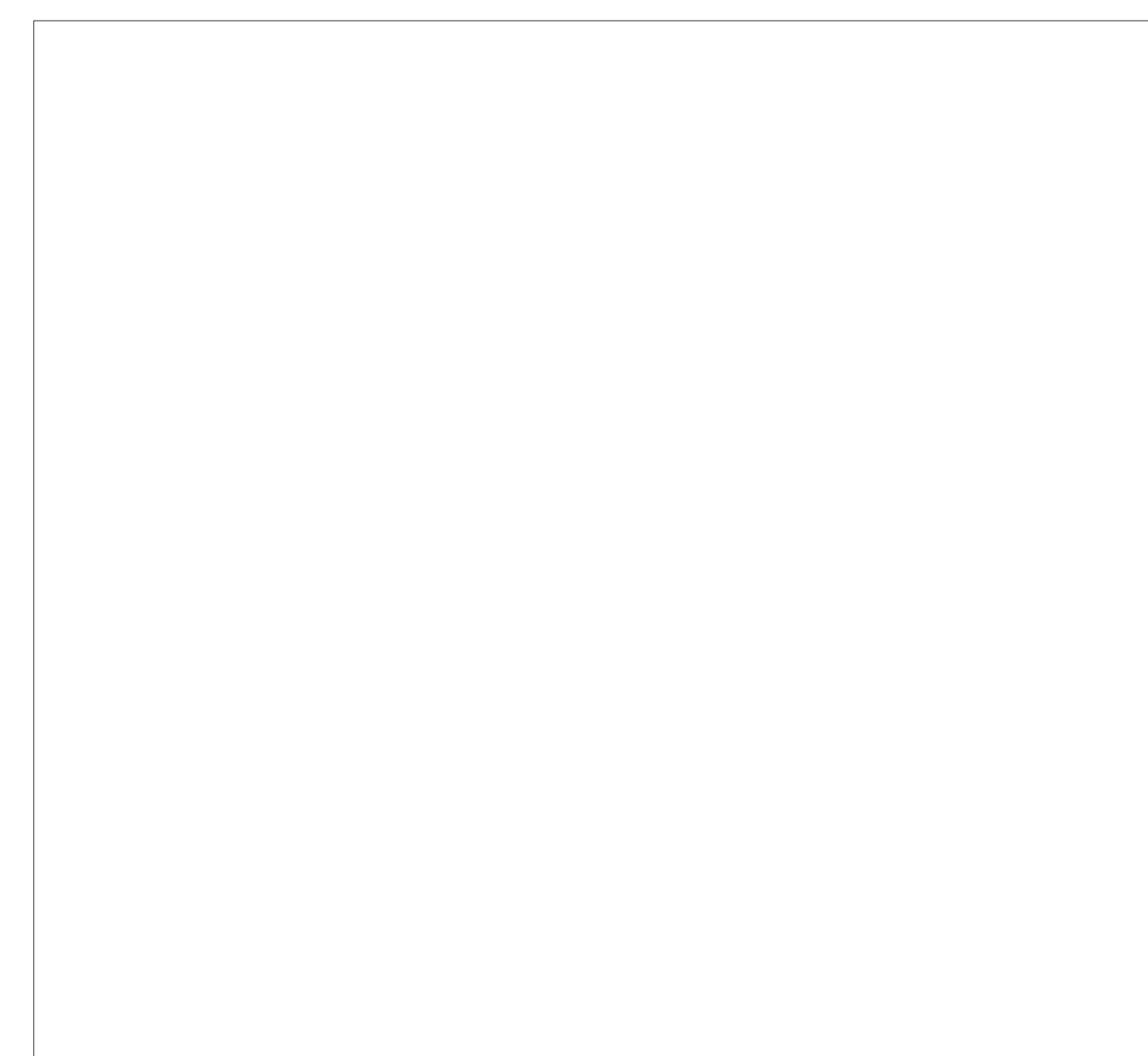

11 PARAPET AT GREEN ROOF
A 613 1:5

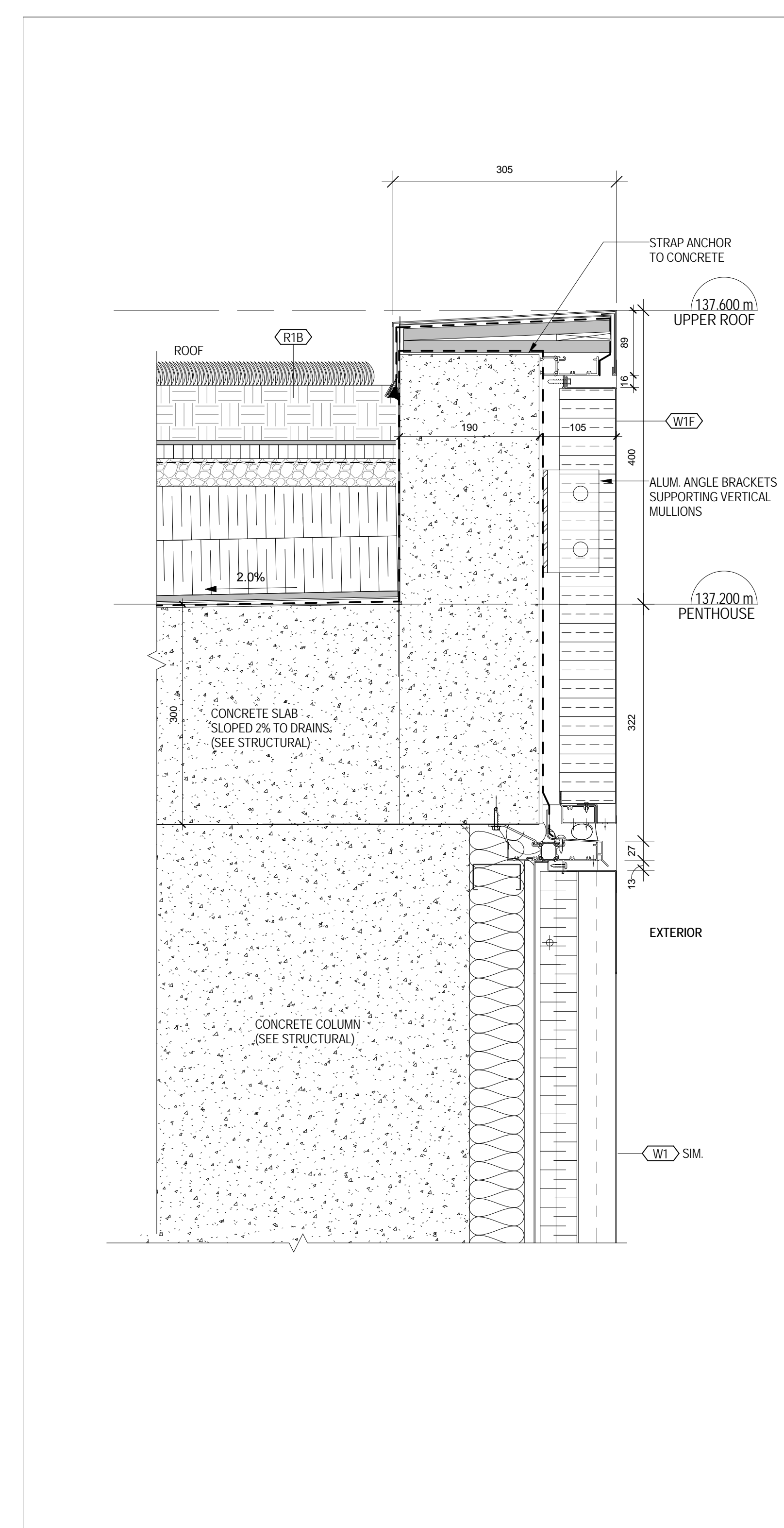

11 PARAPET AT GREEN ROOF
A 613 1:5

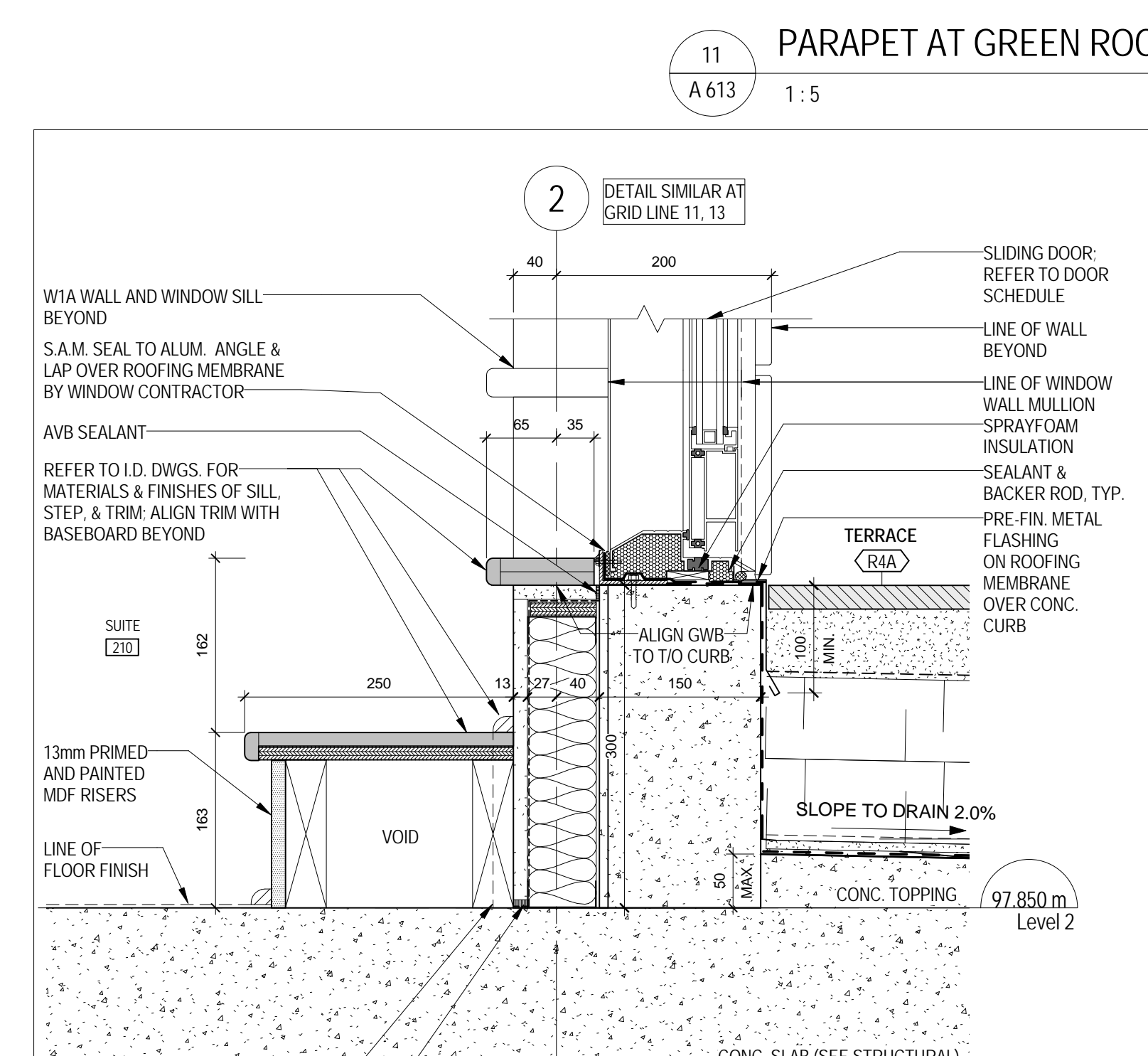

14 TYPICAL SWING DOOR AT 2F RAISED TERRACE
A 613 1:5

SQ ALEXANDRA PARK - BLOCK 11
38 CAMERON ST., TORONTO, ONTARIO M5T 2H2

project no. 12-115
scale: 1:5
drawn by: Author
checked by: Checker
date: 2014-09-22

Teepie Architects

SECTION DETAILS -
TYPICAL WALL
SECTIONS
A 613