

1 FLOOR FINISHES PLAN  
3RD FLOOR SCALE 1:50  
ID1.3.1

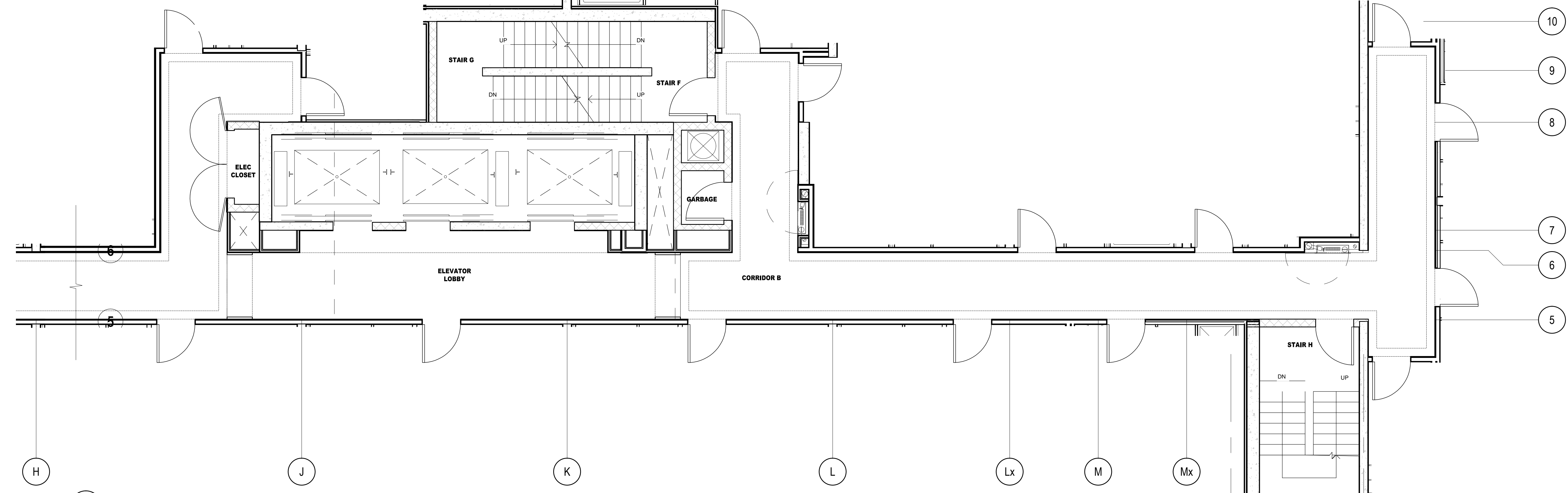

2 FLOOR FINISHES PLAN  
3RD FLOOR SCALE 1:50  
ID1.3.1

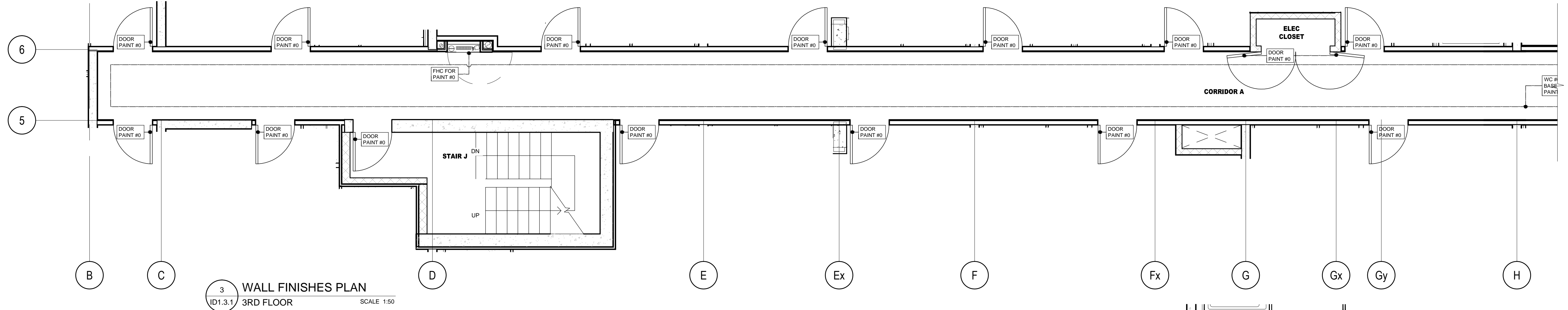

3 WALL FINISHES PLAN  
3RD FLOOR SCALE 1:50  
ID1.3.1

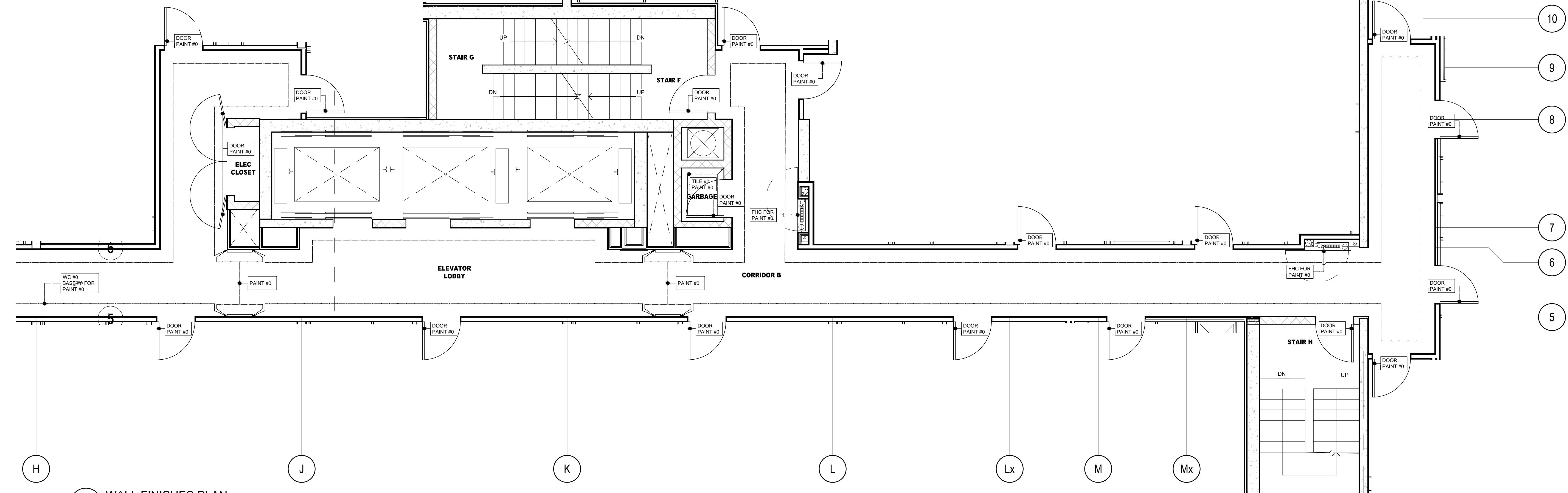

4 WALL FINISHES PLAN  
3RD FLOOR SCALE 1:50  
ID1.3.1

**DO NOT SCALE DRAWINGS.**  
CONTRACTOR MUST VERIFY ALL DRAWINGS, DIMENSIONS, DETAILS AND SPECIFICATIONS, AND REPORT ANY DISCREPANCIES TO UNIOB1 INC. BEFORE PROCEEDING WITH WORK. MATERIALS MAY NOT BE SUBSTITUTED WITHOUT WRITTEN APPROVAL FROM UNIOB1 INC.  
ALL DRAWINGS AND SPECIFICATIONS ARE INSTRUMENTS OF SERVICE AND THE PROPERTY OF UNIOB1 INC. WHICH MUST BE RETURNED AT THE COMPLETION OF THE WORK.

PRINTED: 10-Jun-14

NO.	DATE	COMMENTS	INI

UNIOB1

**UNIOB1 INC.**  
183 BATHURST STREET, STE. 201  
TORONTO, ON, M5T 2R7, CANADA  
TEL: 416-597-1576 FAX: 416-597-2139

PROJECT NAME:		<b>ALEXANDRA PARK MAIN BUILDING</b>	
BLOCK 11 ON, Canada			
PROJECT NO.:	13-949	DATE STARTED:	07 AUG / 13
DRAWINGS:		SCALE:	1 : 50
3RD FLOOR FLOOR FINISHES PLAN & WALL FINISHES PLAN		DRAWN BY:	AP
		APPROVED BY:	KC
		DRAWING NO.:	<b>ID 1.3.1</b>