

DO NOT SCALE DRAWINGS.

CONTRACTOR MUST VERIFY ALL DRAWINGS, DIMENSIONS, DETAILS AND SPECIFICATIONS, AND REPORT ANY DISCREPANCIES TO UNION 31 INC. BEFORE PROCEEDING WITH WORK. MATERIALS MAY NOT BE SUBSTITUTED WITHOUT WRITTEN APPROVAL FROM UNION 31 INC.
ALL DRAWINGS AND SPECIFICATIONS ARE INSTRUMENTS OF SERVICE AND THE PROPERTY OF UNION 31 INC. WHICH MUST BE RETURNED AT THE COMPLETION OF THE WORK.

PRINTED: 23-Aug-14

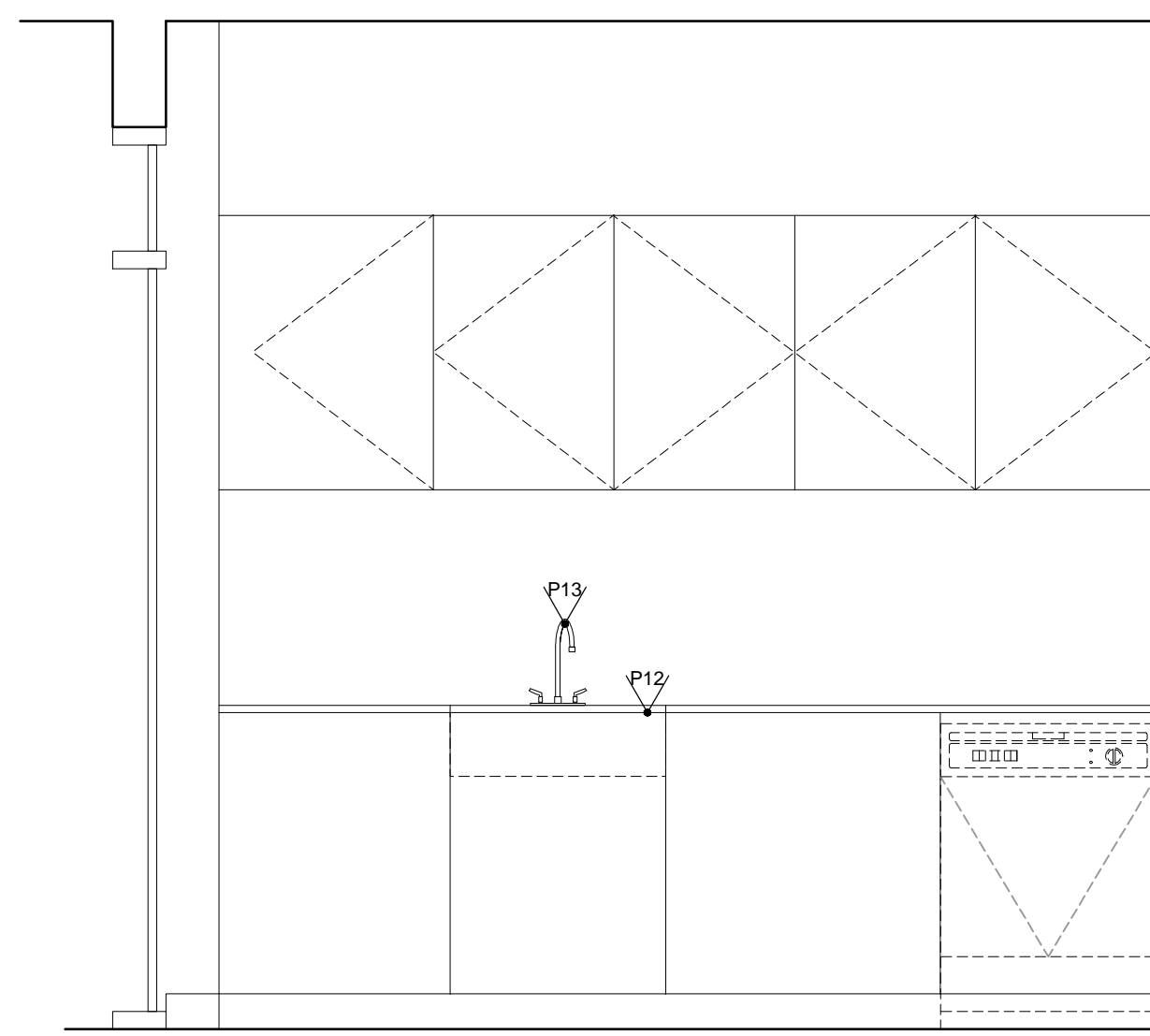

1 ELEVATION
ID2.0.2 P1 LEVEL STAFF LUNCH ROOM SCALE 1:20

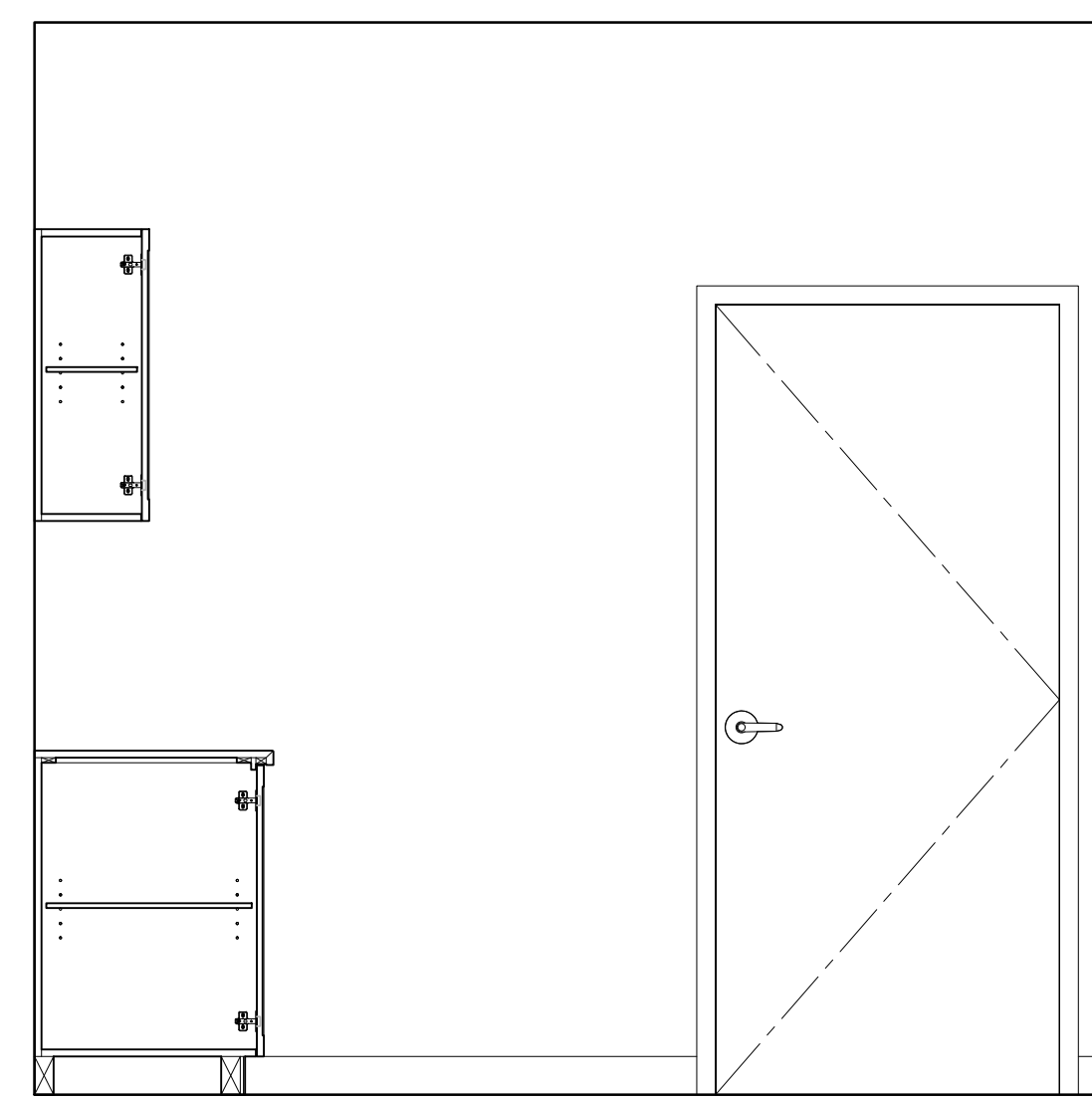

2 ELEVATION
ID2.0.2 P1 LEVEL STAFF LUNCH ROOM SCALE 1:20

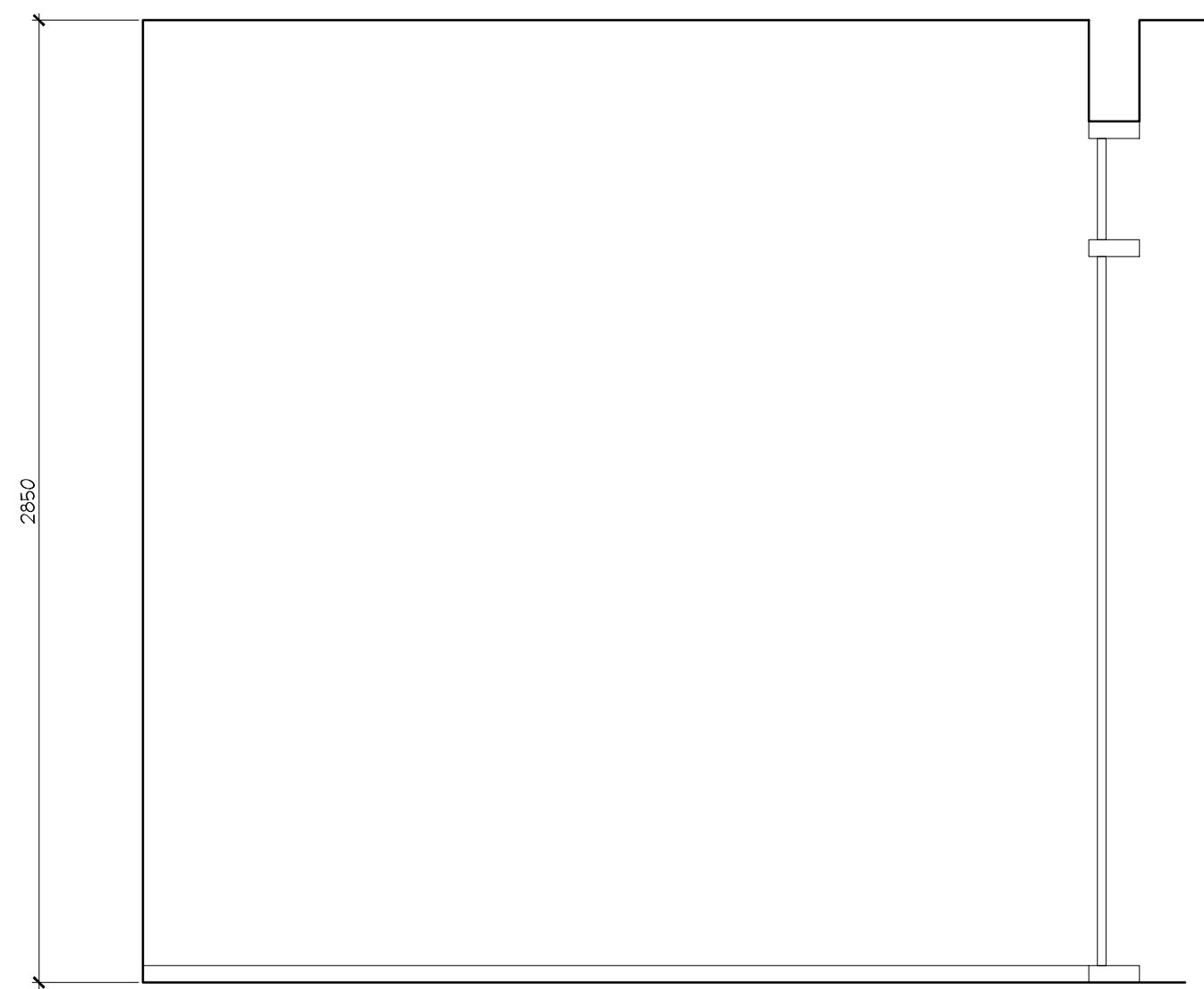

3 ELEVATION
ID2.0.2 P1 LEVEL STAFF LUNCH ROOM SCALE 1:20

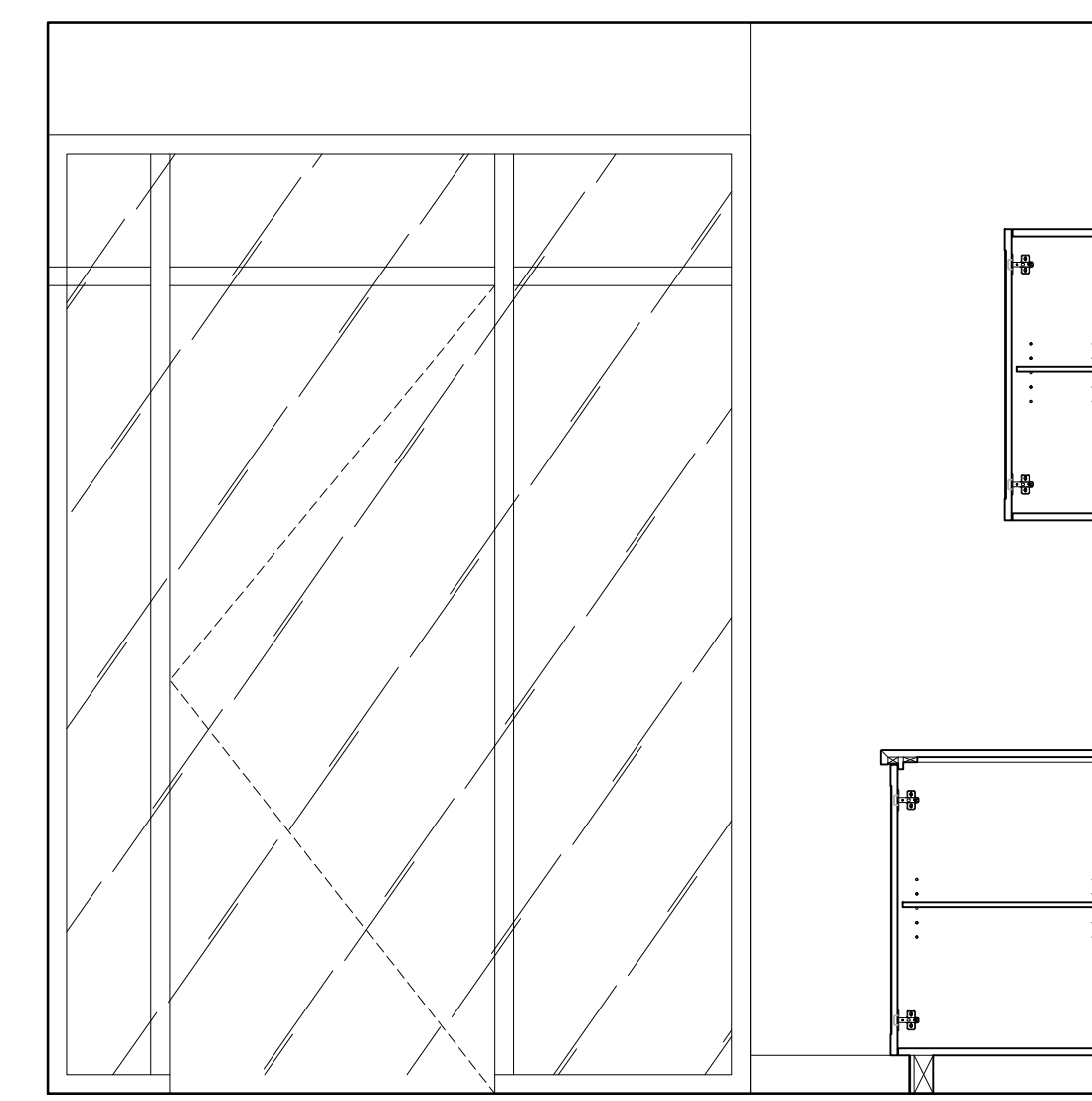

4 ELEVATION
ID2.0.2 P1 LEVEL STAFF LUNCH ROOM SCALE 1:20

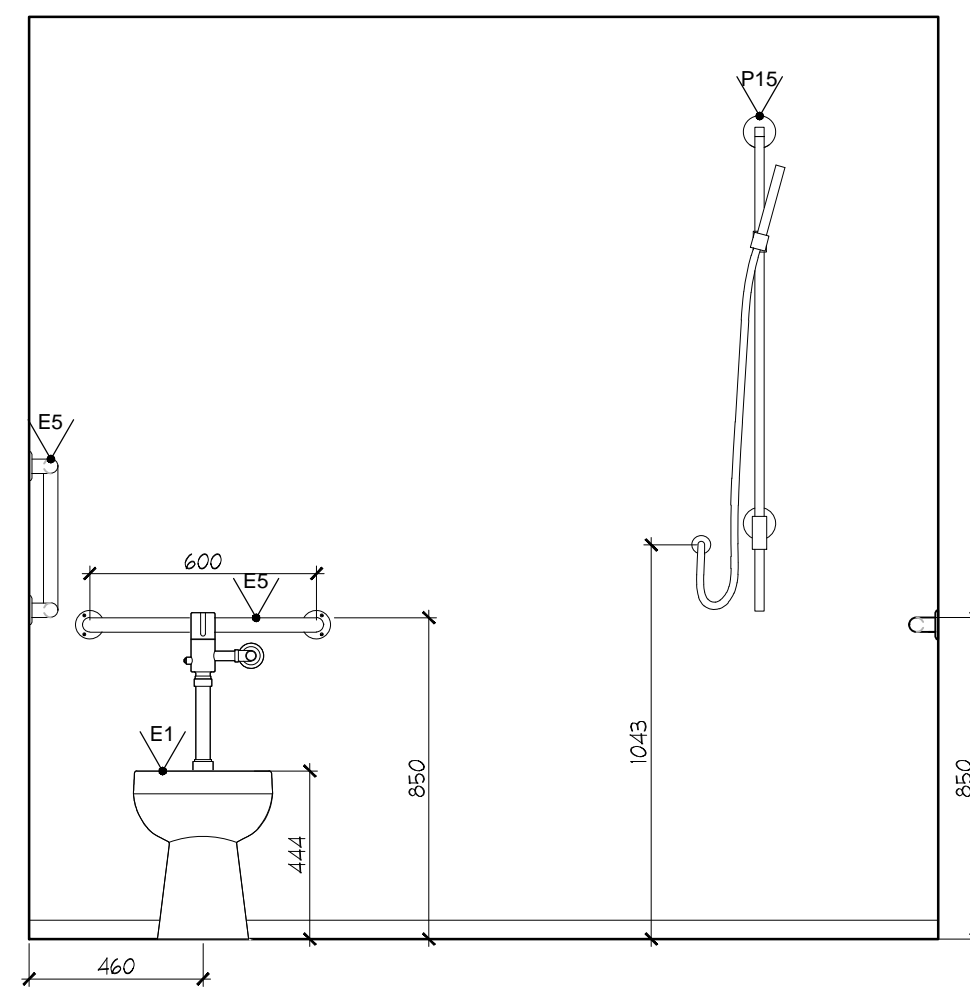

5 ELEVATION
ID2.0.2 P1 LEVEL STAFF W/ CH/ SHOWER ROOM SCALE 1:20

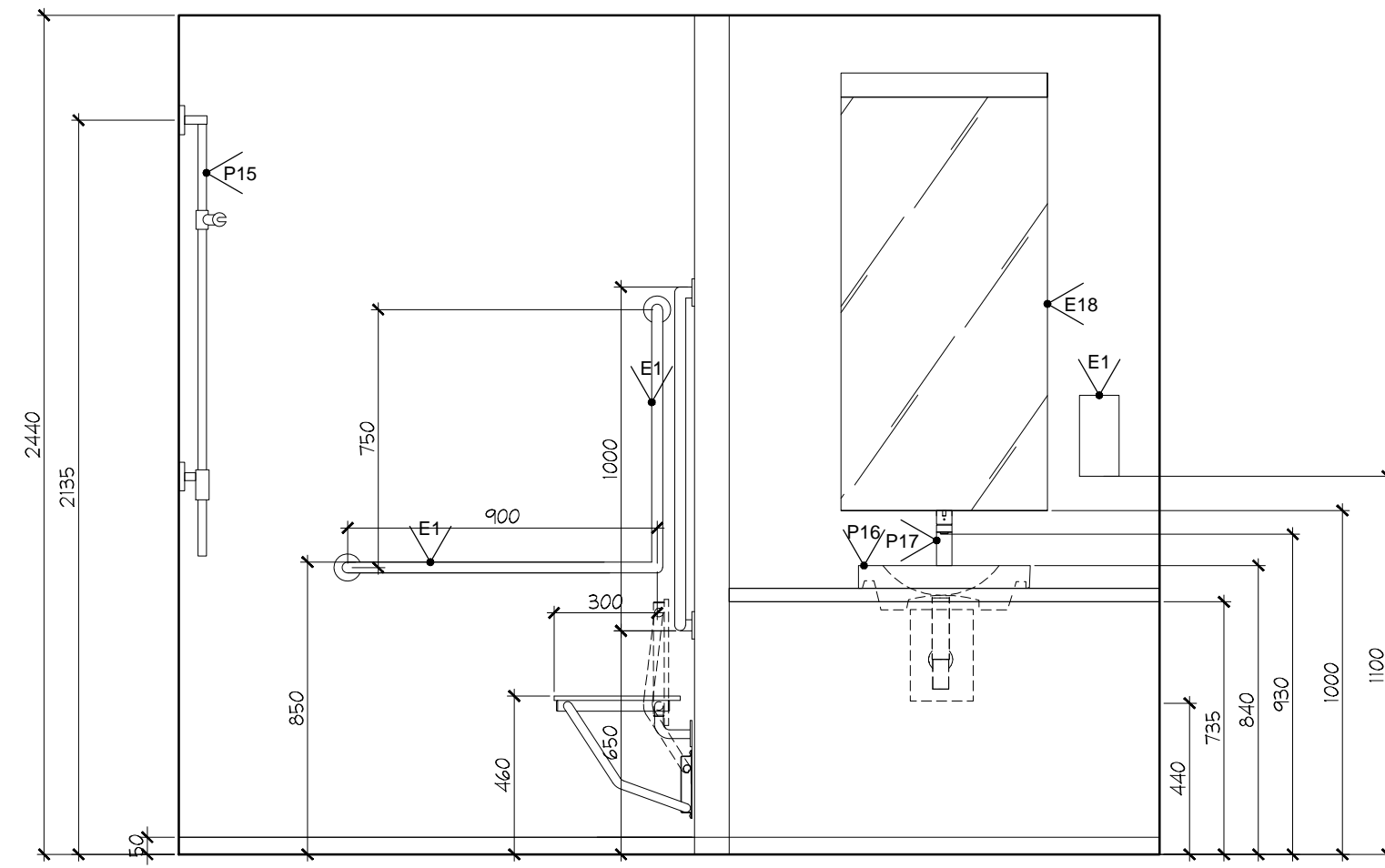

6 ELEVATION
ID2.0.2 P1 LEVEL STAFF W/ CH/ SHOWER ROOM SCALE 1:20

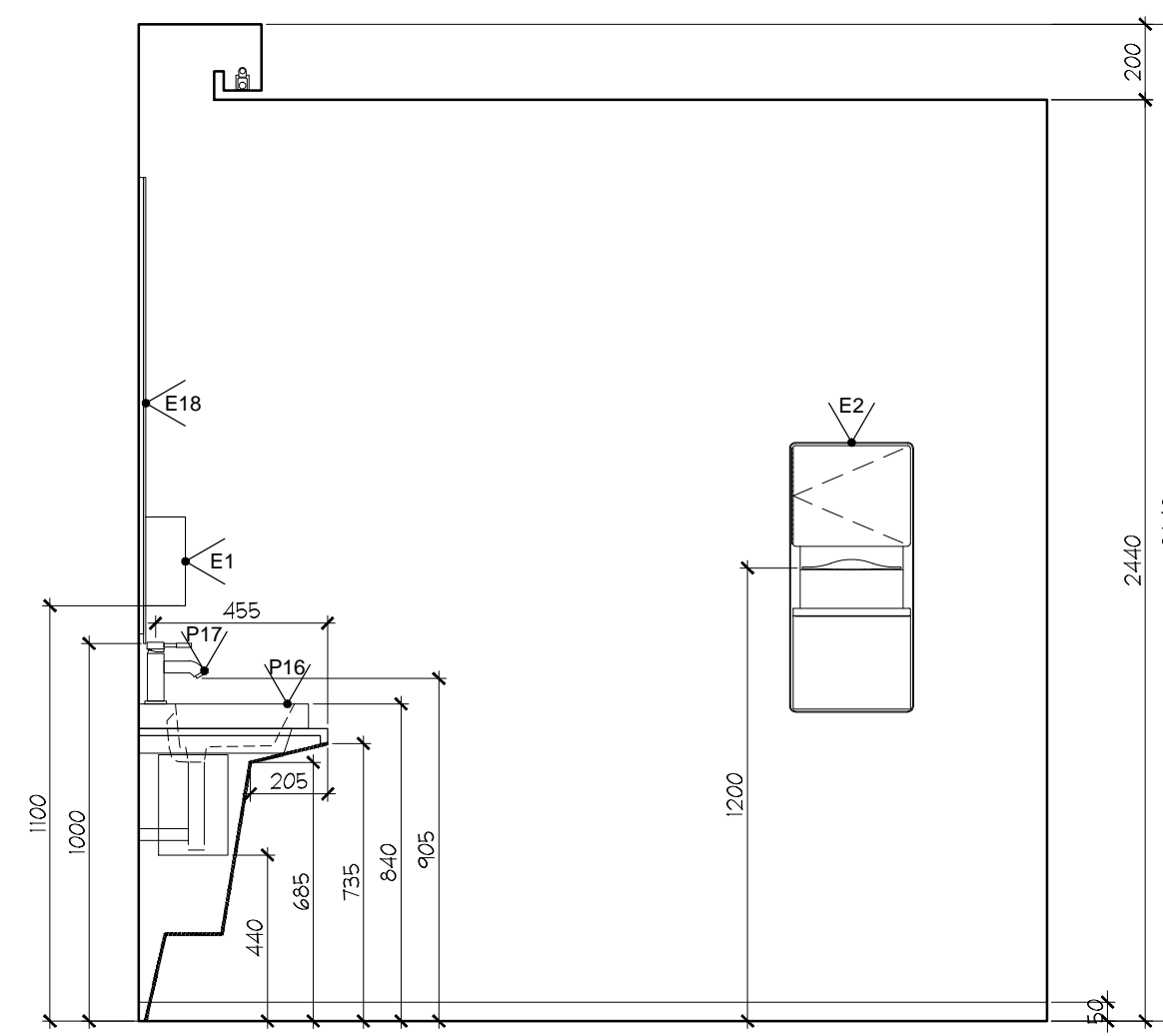

7 ELEVATION
ID2.0.2 P1 LEVEL STAFF W/ CH/ SHOWER ROOM SCALE 1:20

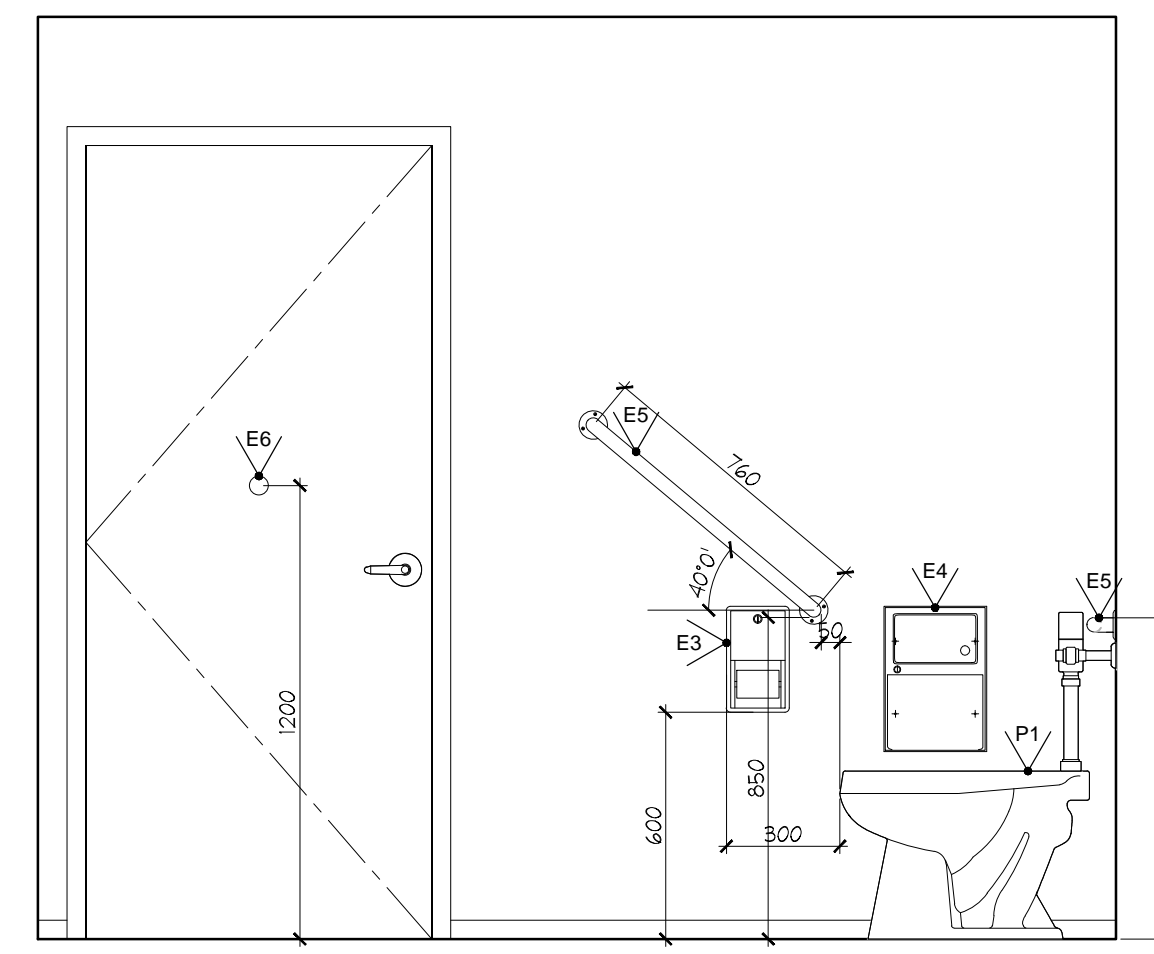

8 ELEVATION
ID2.0.2 P1 LEVEL STAFF W/ CH/ SHOWER ROOM SCALE 1:20

NOTE:
INSTALL ALL BARRIER FREE
WASHROOM COMPONENTS
ACCORDING TO CBC
REQUIREMENTS

02	22 AUG / 14	ISSUED FOR PERMIT	AP
01	15 AUG / 14	ISSUED FOR PERMIT	AP
NO.	DATE	COMMENTS	INI
REVISIONS:			

UNION31

UNION31 INC.
183 BATHURST STREET, STE. 201
TORONTO, ON, M5T 2R7, CANADA
TEL: 416-597-1576 FAX: 416-597-2139

PROJECT NAME:
**ALEXANDRA PARK
MAIN BUILDING**
BLOCK 11
ON, Canada

PROJECT NO.: 13-949

DRAWINGS:
**PARKING LEVEL
ELEVATIONS**

DATE STARTED: 07 AUG / 13 DRAWING NO.:
SCALE: 1:20 ID
DRAWN BY: AP
APPROVED BY: KC 2.0.2