

DO NOT SCALE DRAWINGS.

CONTRACTOR MUST VERIFY ALL DRAWINGS, DIMENSIONS, DETAILS AND SPECIFICATIONS, AND REPORT ANY DISCREPANCIES TO UNION 31 INC. BEFORE PROCEEDING WITH WORK. MATERIALS MAY NOT BE SUBSTITUTED WITHOUT WRITTEN APPROVAL FROM UNION 31 INC.
ALL DRAWINGS AND SPECIFICATIONS ARE INSTRUMENTS OF SERVICE AND THE PROPERTY OF UNION 31 INC. WHICH MUST BE RETURNED AT THE COMPLETION OF THE WORK.

PRINTED: 26-Jan-15

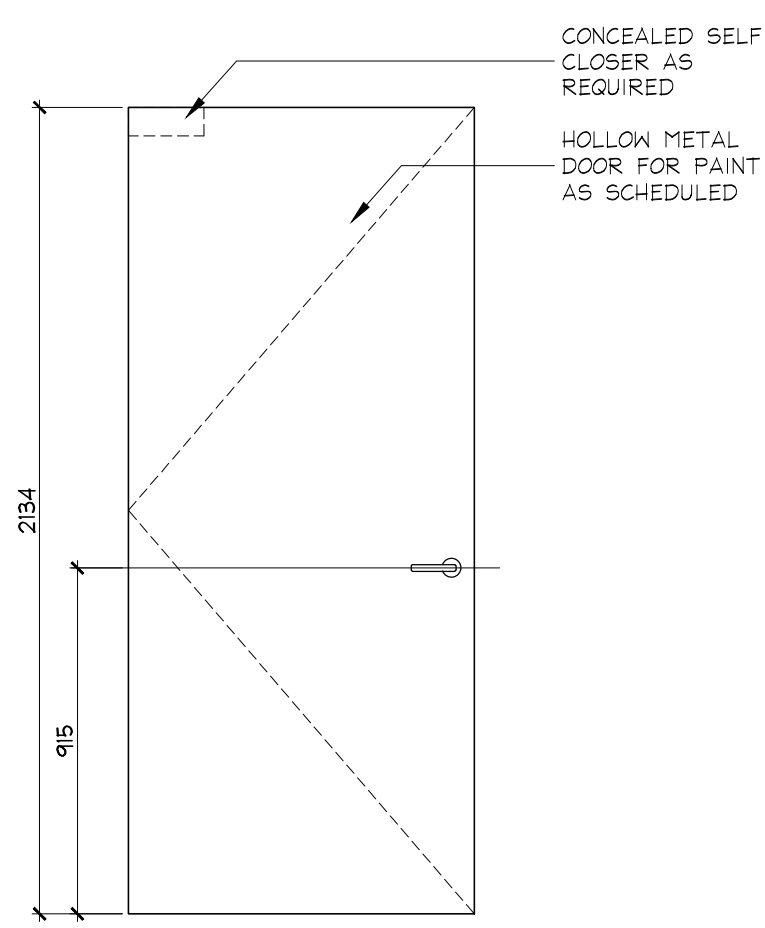

TYPICAL TYPE "TYP.1" LOCKER DOORS

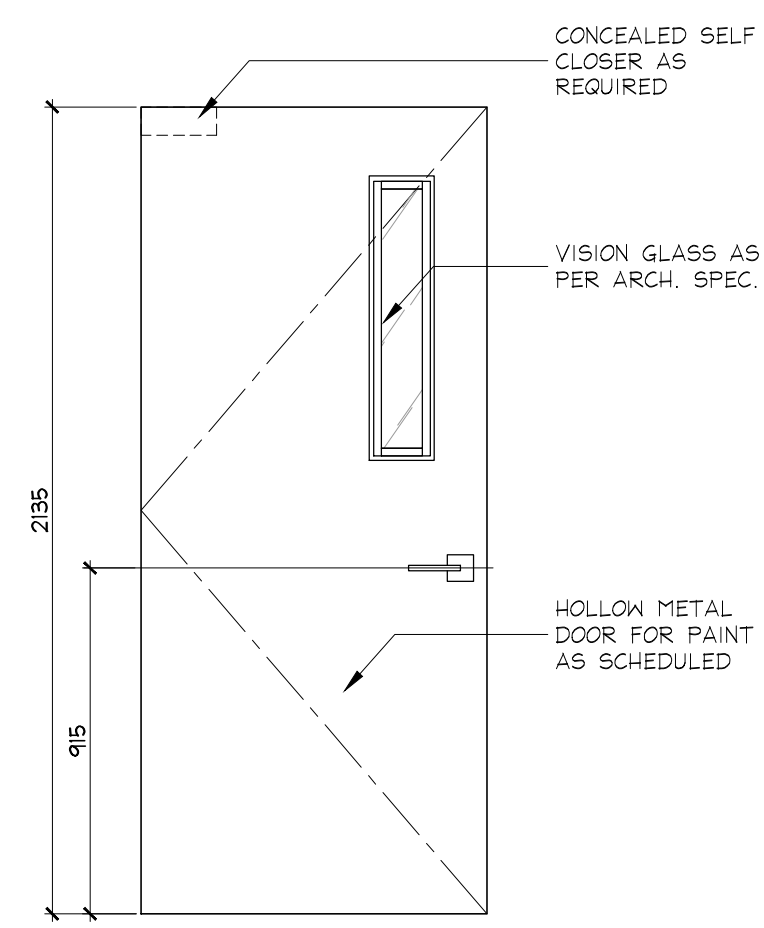

TYP. EXIT STAIR DOORS "TYP.2"

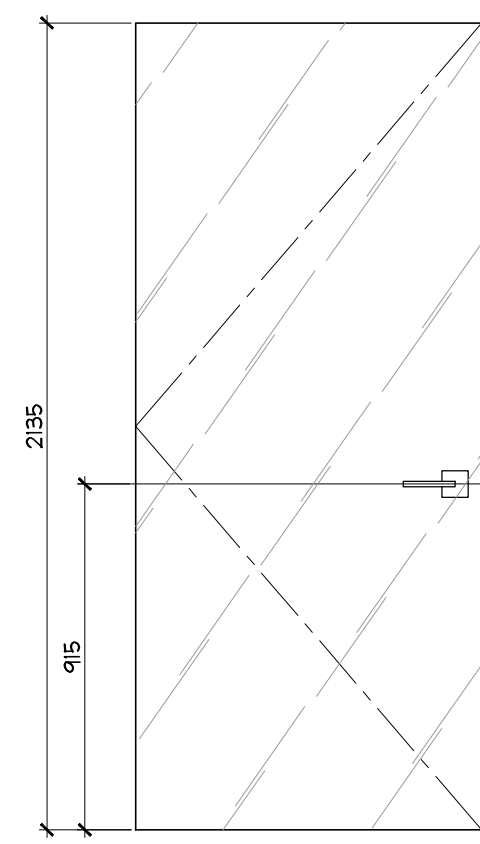

PARKING LEVEL 2 DOORS P201.1, P201.X, P201.3

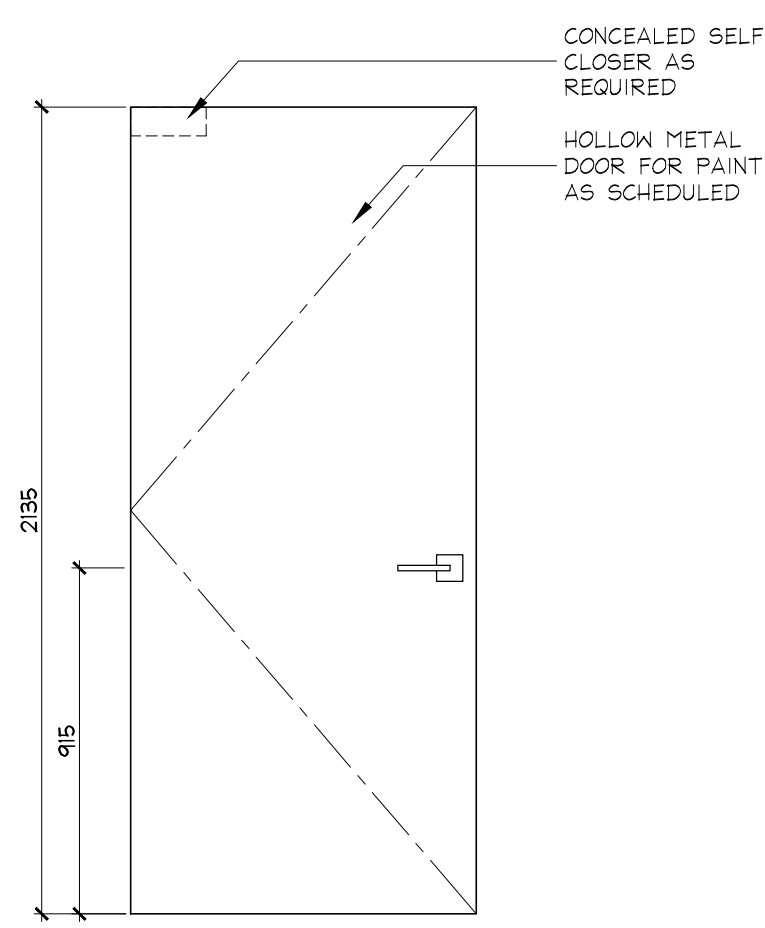

PARKING LEVEL 2 DOOR P201.2

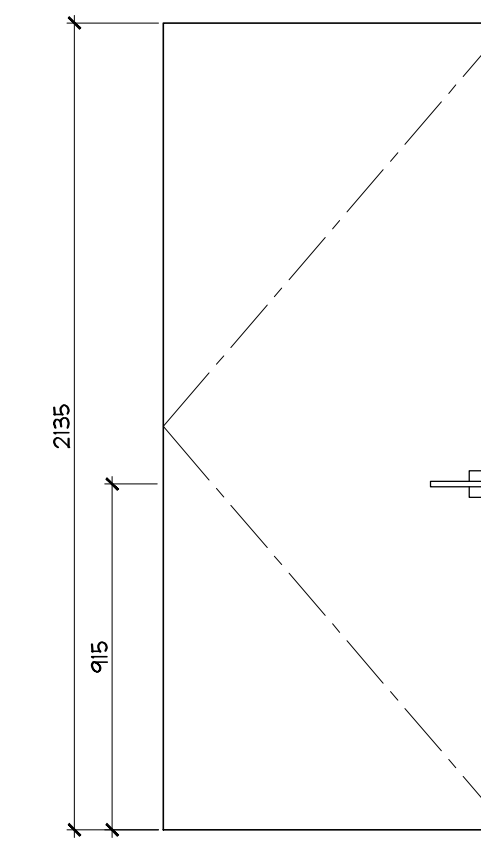

PARKING LEVEL 1 DOORS P110.1, P101

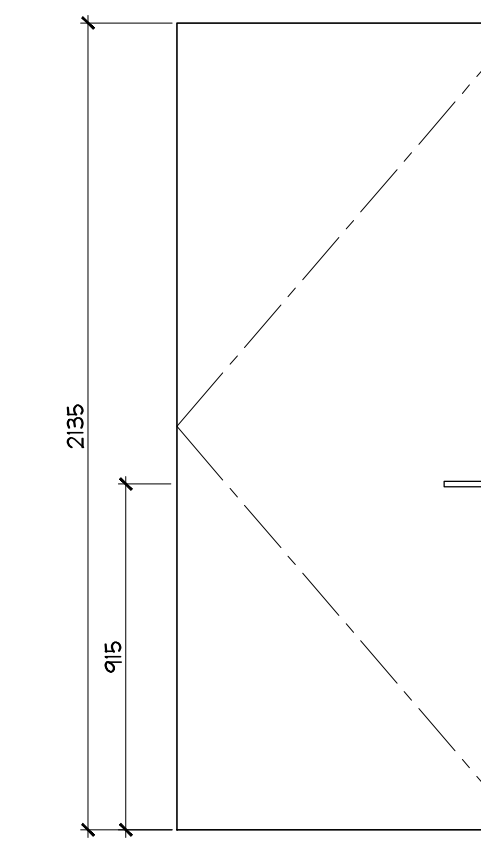

PARKING LEVEL 1 DOORS P110.1, P110

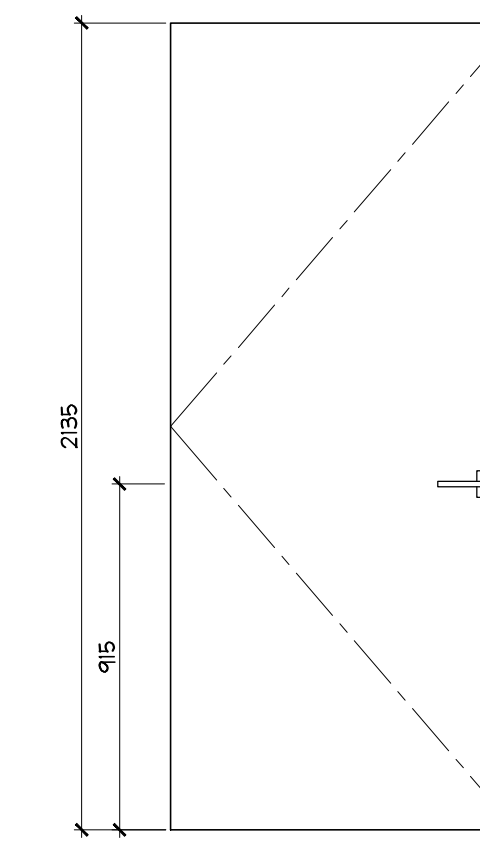

PARKING LEVEL 1 DOOR P117

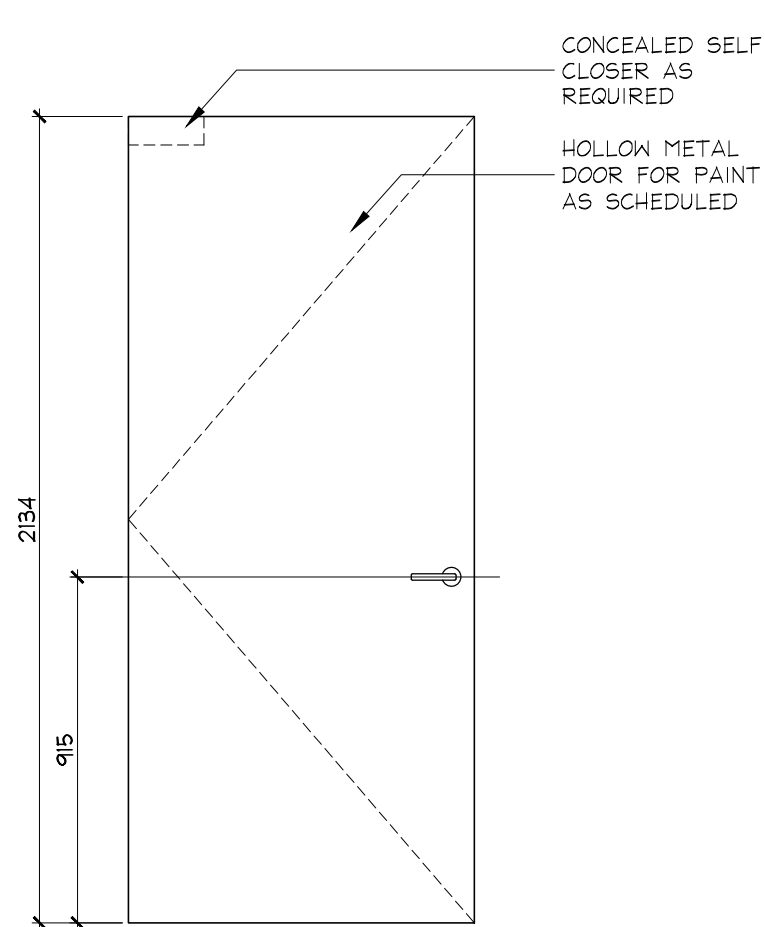

GROUND FLOOR DOOR 1-SA.3

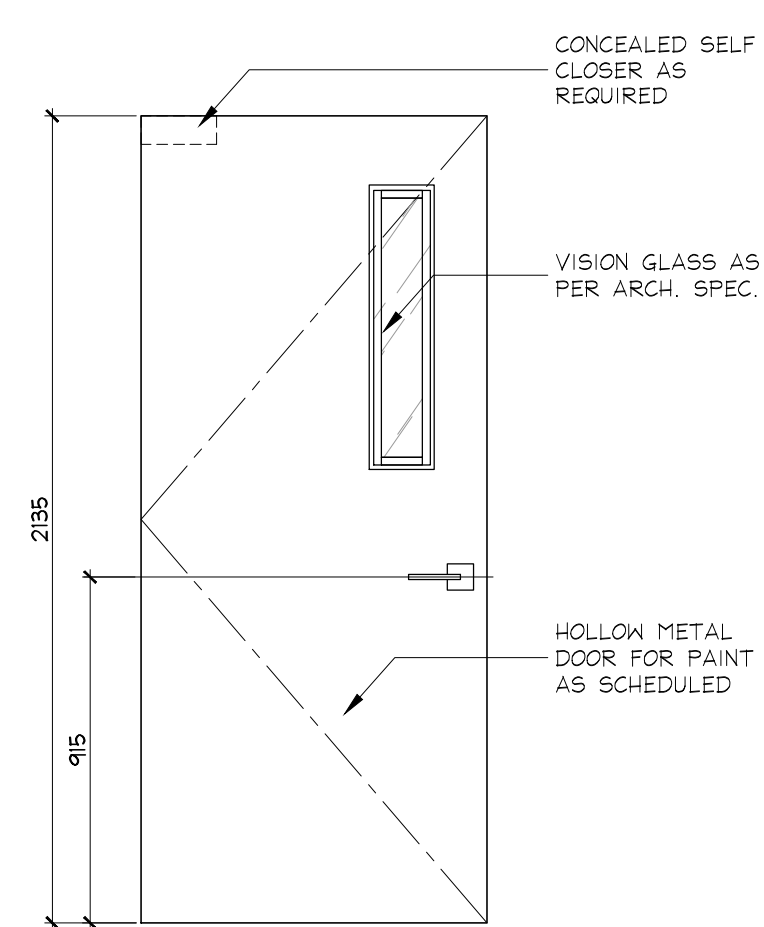

GROUND FLOOR DOORS 131.1, 133, 144, 145.2

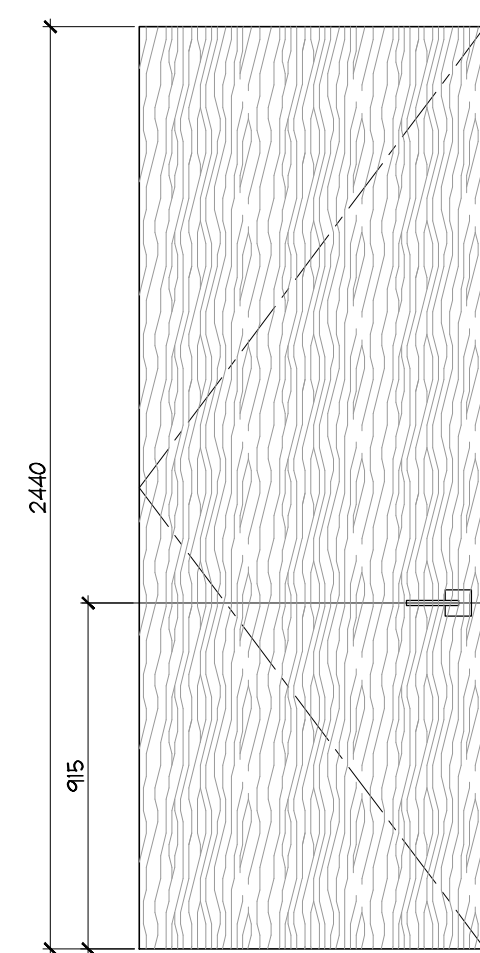

GROUND FLOOR DOOR 138 MAIL SORTING

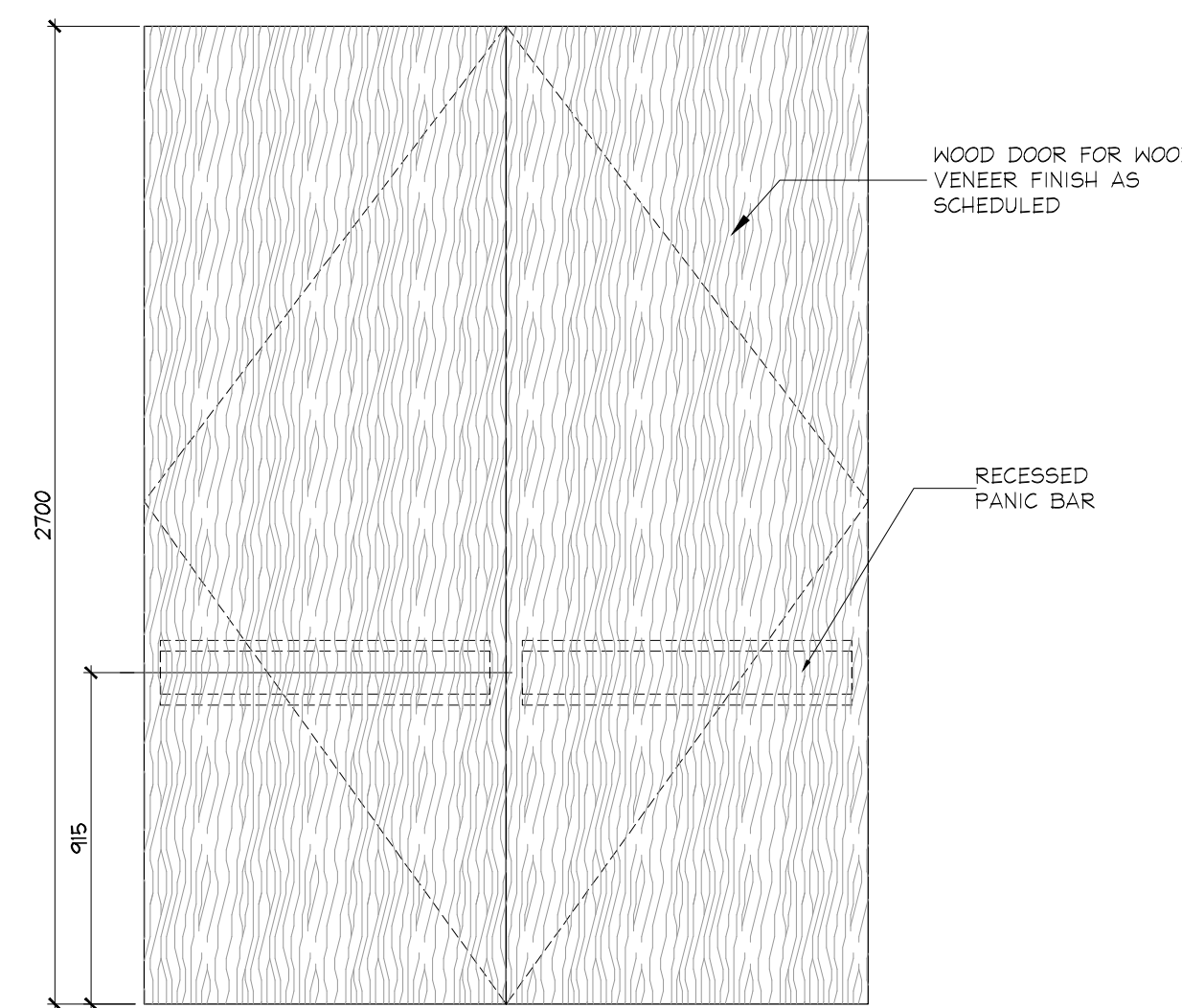

GROUND FLOOR DOOR 140.1 ELEVATOR LOBBY

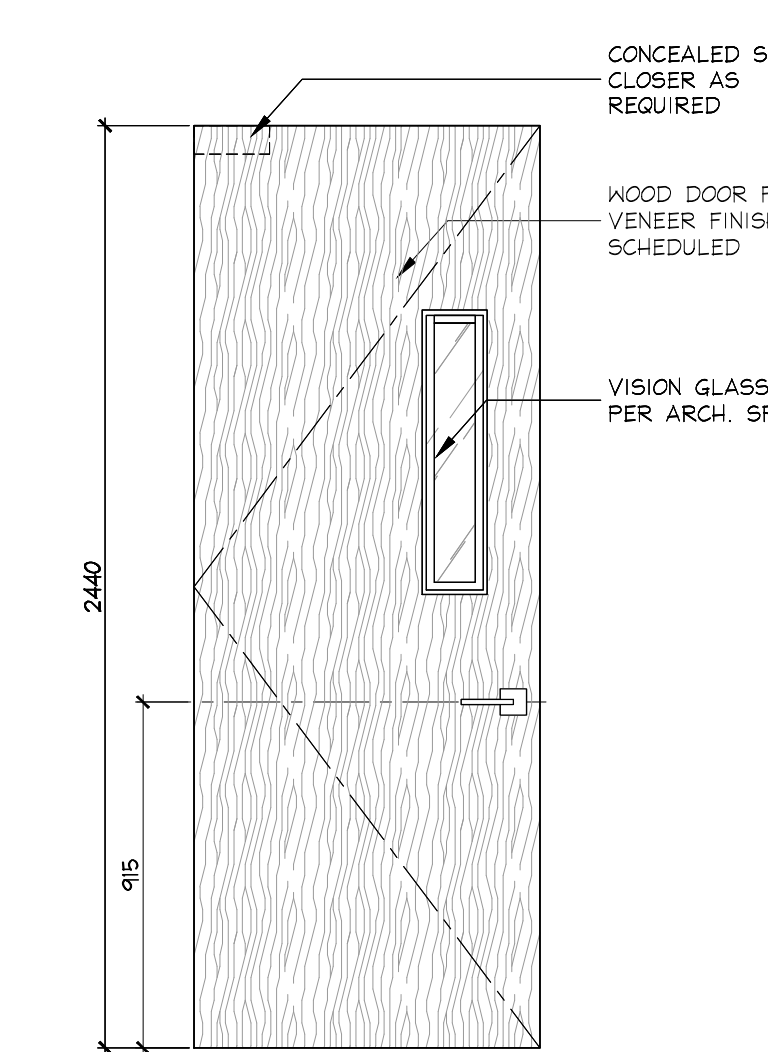

GROUND FLOOR DOOR 140.2 CORRIDOR B TO LOBBY

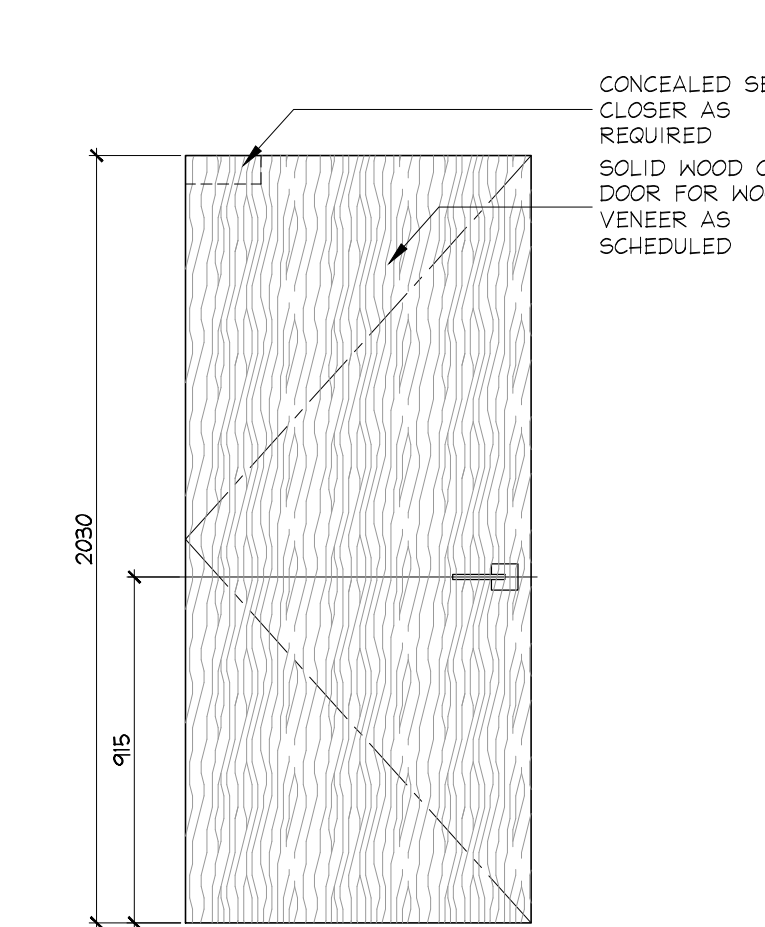

GROUND FLOOR DOORS 143B, 143C, 161A, 163A VFCU ACCESS PANEL

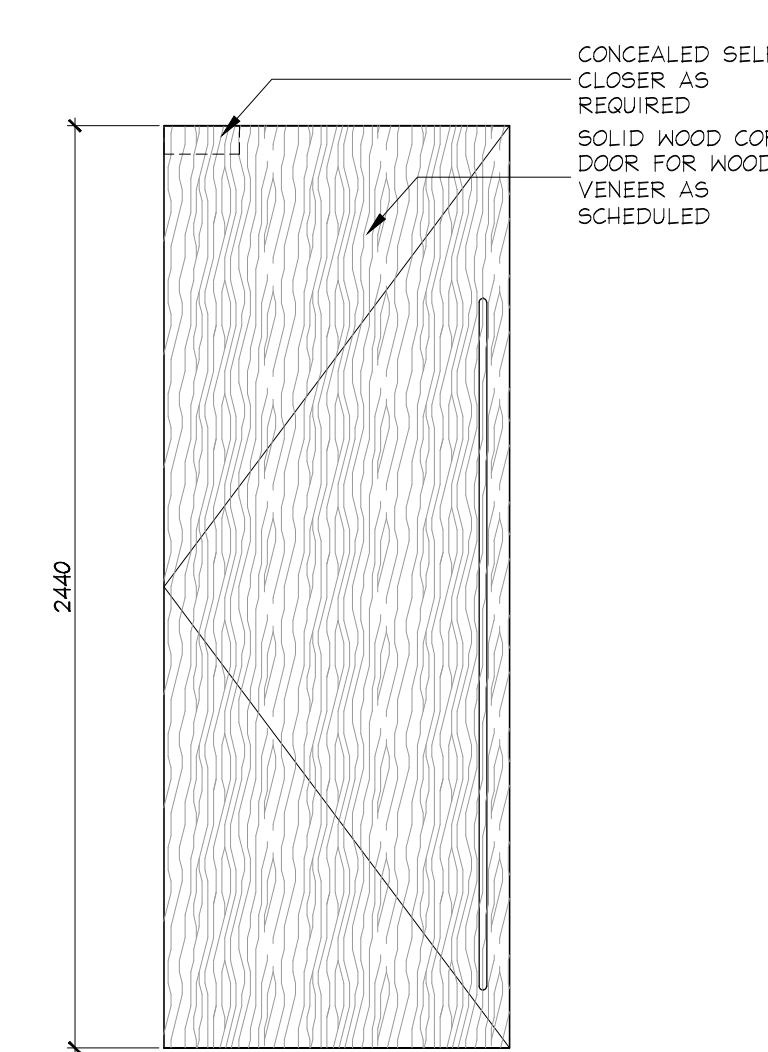

GROUND FLOOR DOORS 146A/B, 151A/B, 147, 148, 153 MEN'S / WOMEN'S CHANGEROOM VESTIBULE AMENITY KITCHENETTE

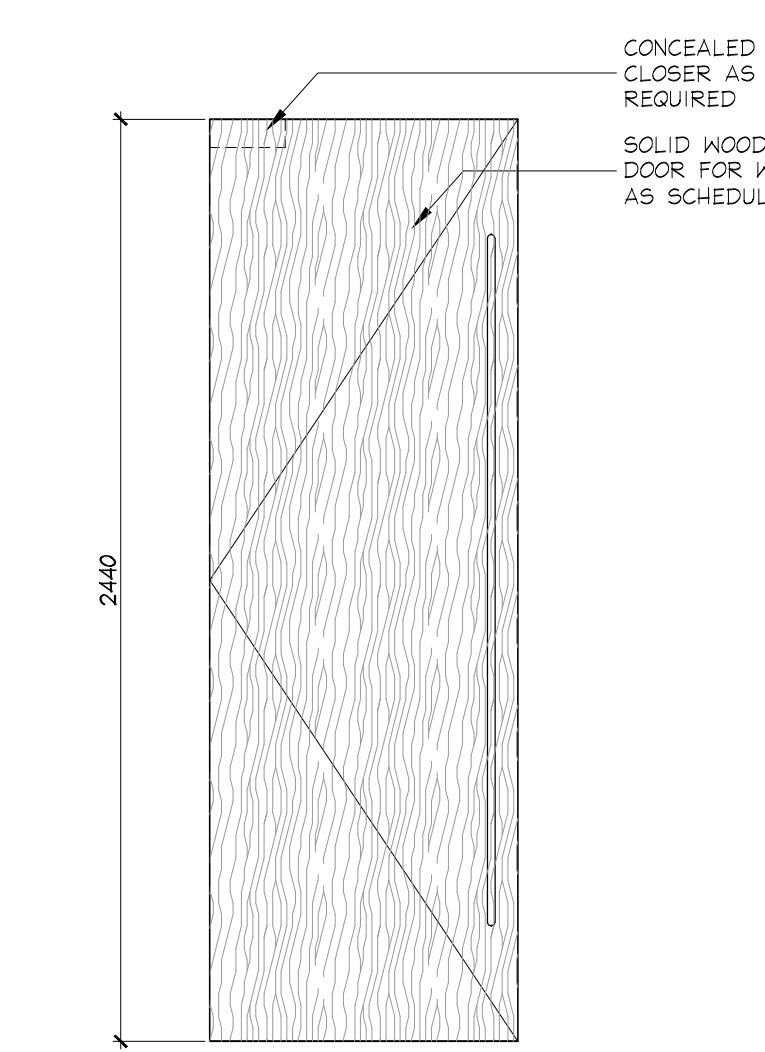

GROUND FLOOR DOORS 152, 162 MEN'S / WOMEN'S WC

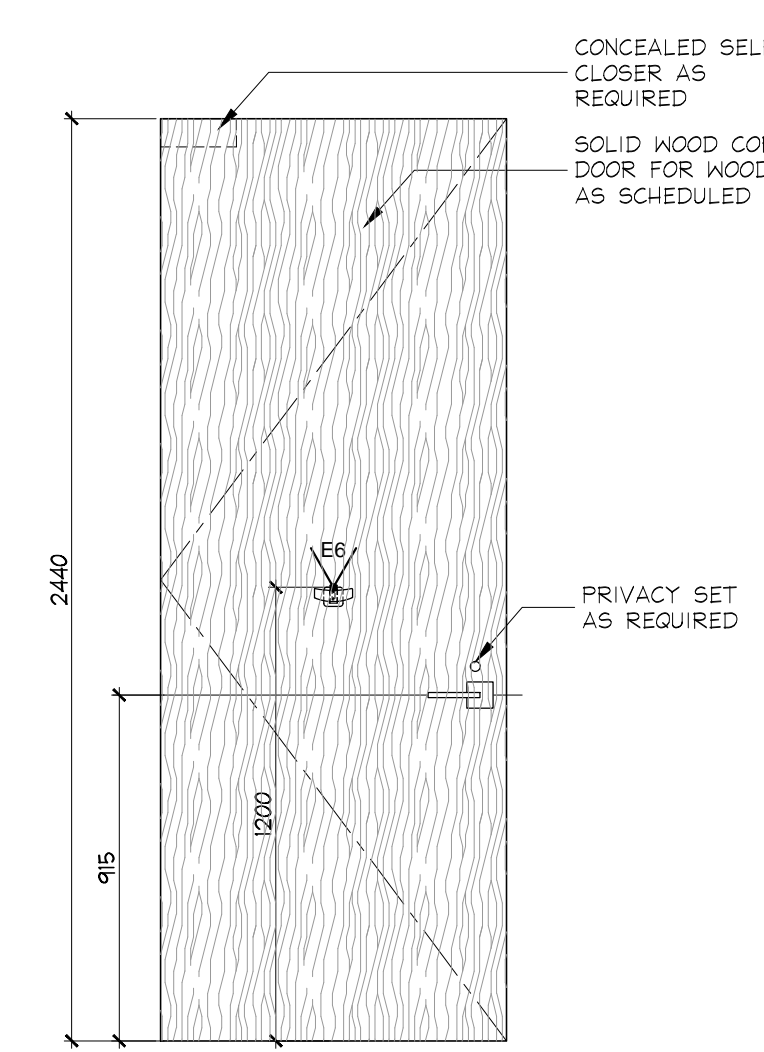

GROUND FLOOR DOORS 148, 153 (INTERIOR) MEN'S / WOMEN'S WC BF

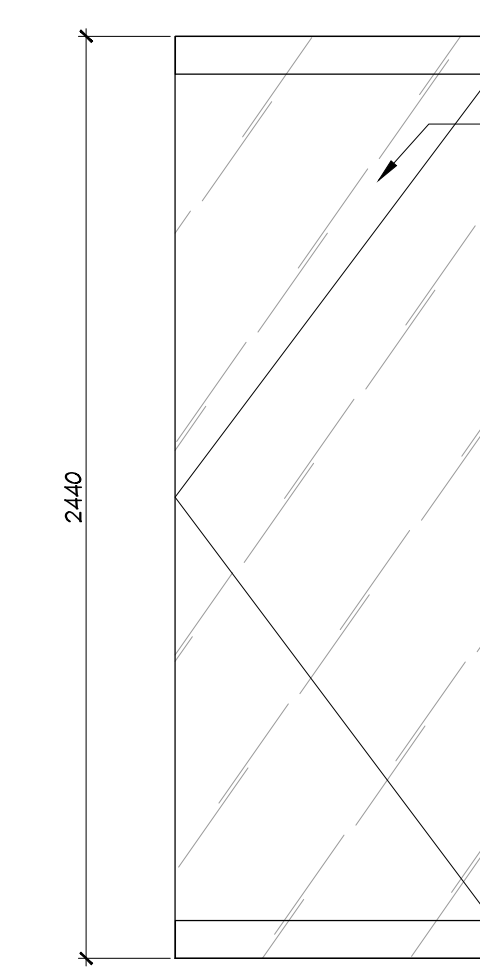

GROUND FLOOR DOORS 149.1, 149.2 MEN'S / WOMEN'S CHANGEROOM TO WHIRLPOOL SPA

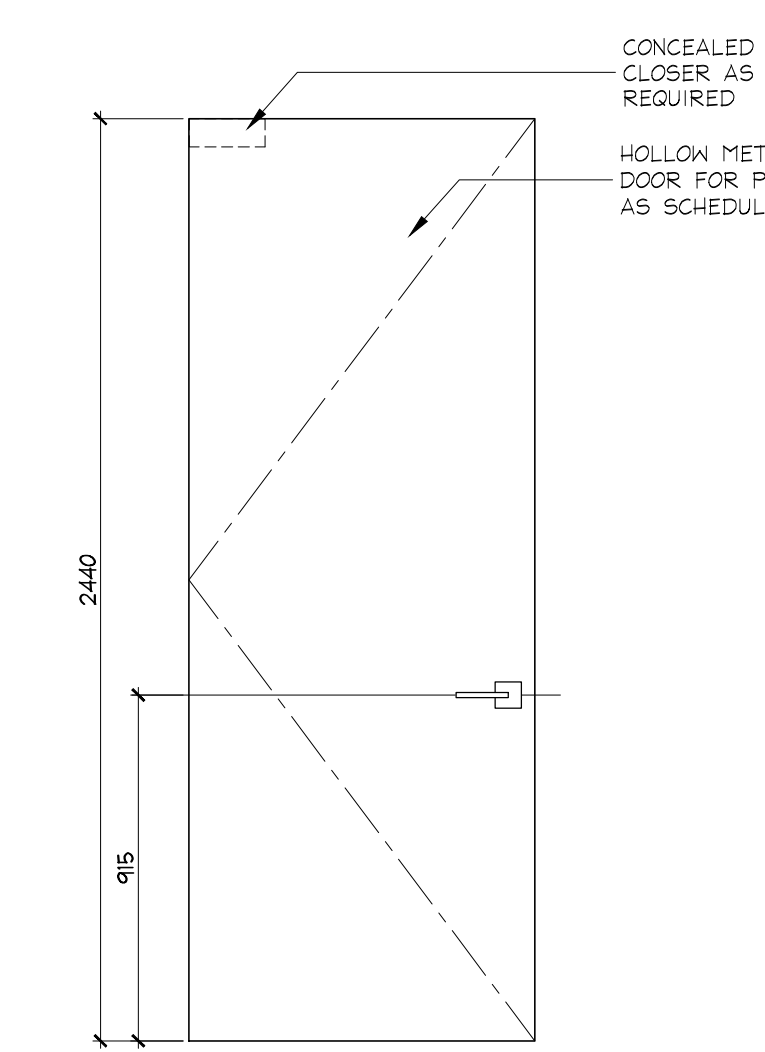

GROUND FLOOR DOOR 150 JANITOR CLOSET IN WOMEN'S CHANGEROOM

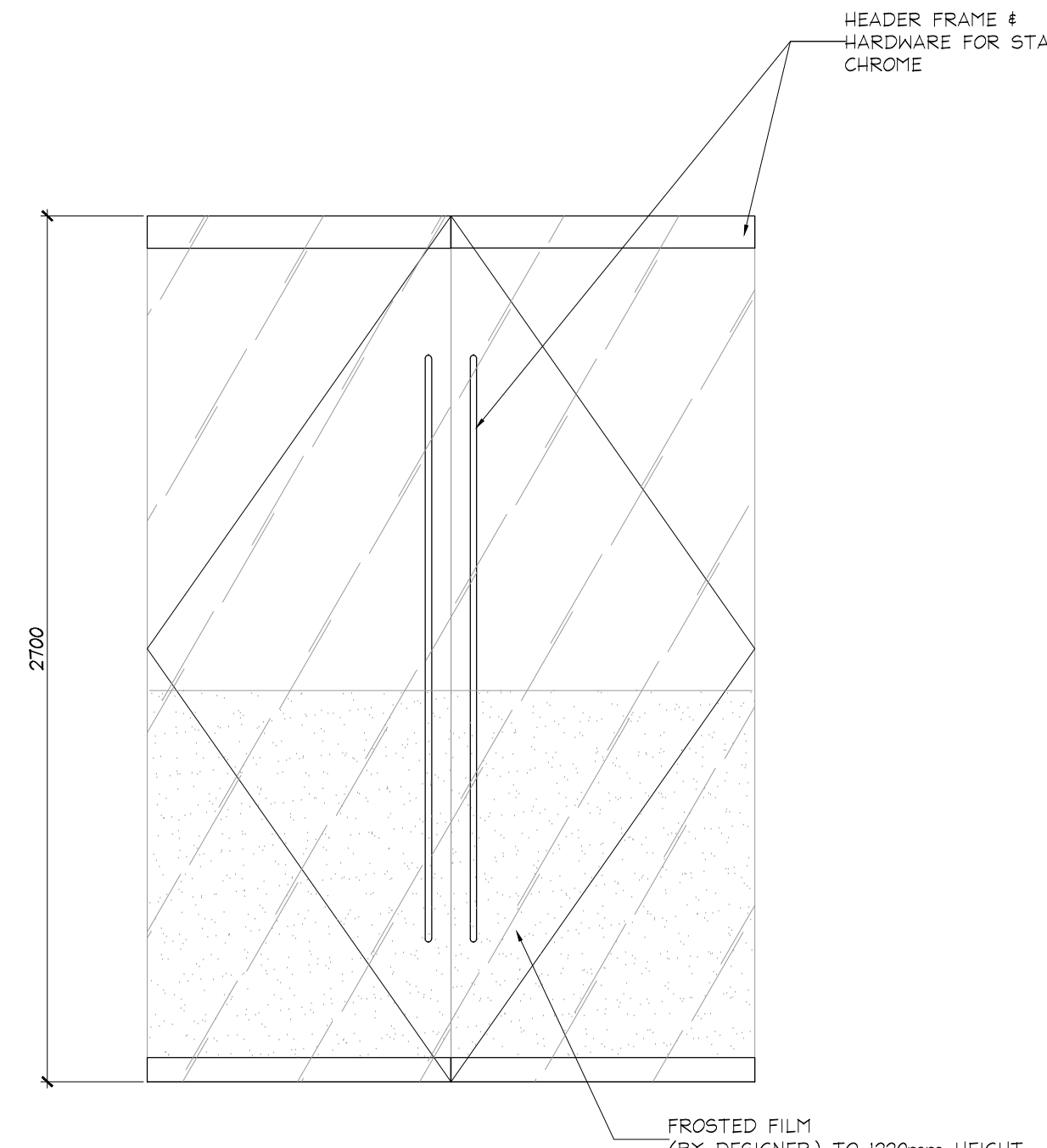

GROUND FLOOR DOOR 154 CORRIDOR D TO FITNESS AREA

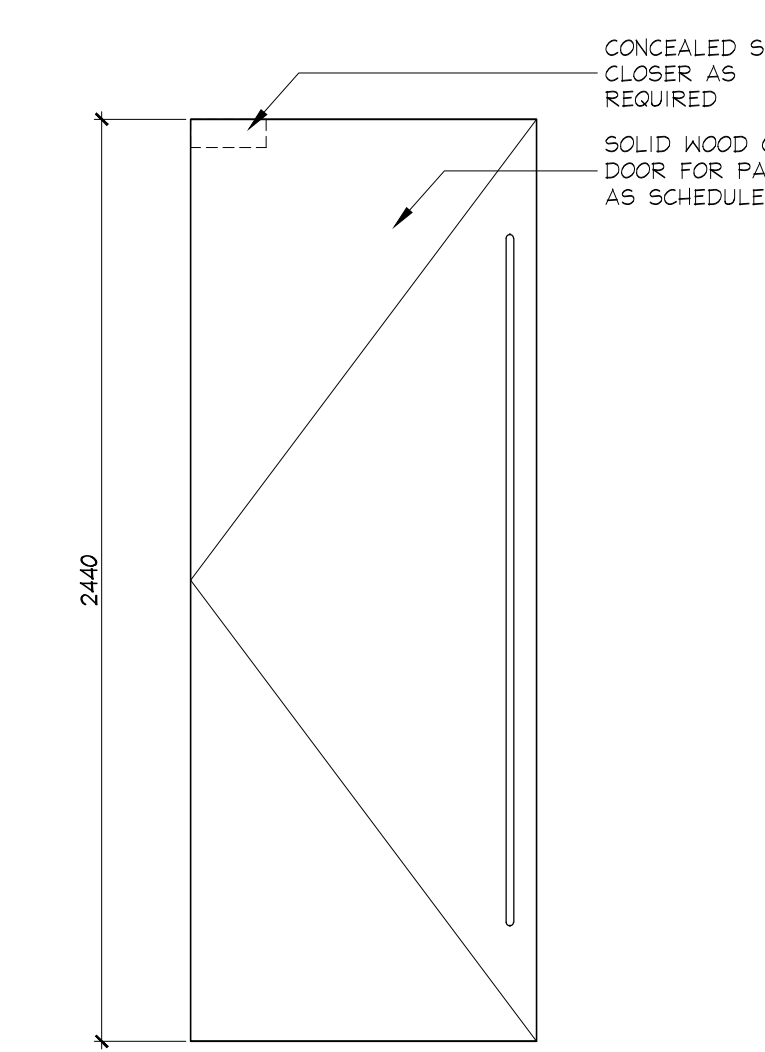

GROUND FLOOR DOORS 156, 157 BARRIER FREE WC

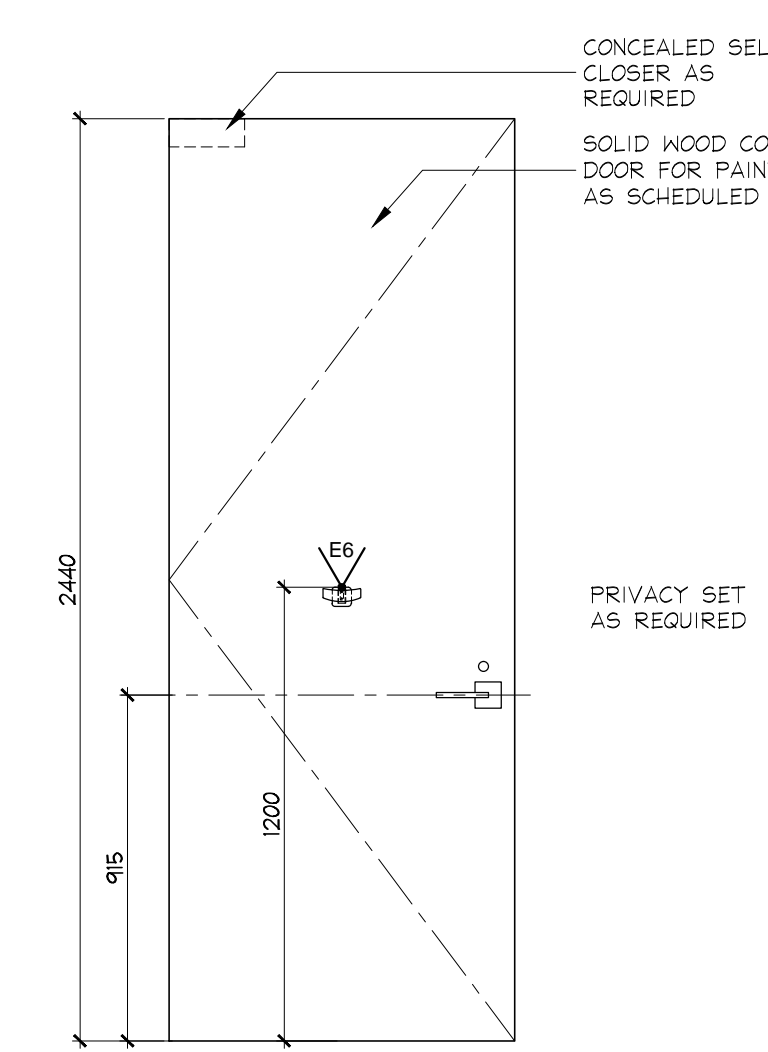

GROUND FLOOR DOORS 156, 157 (INTERIOR) BARRIER FREE WC

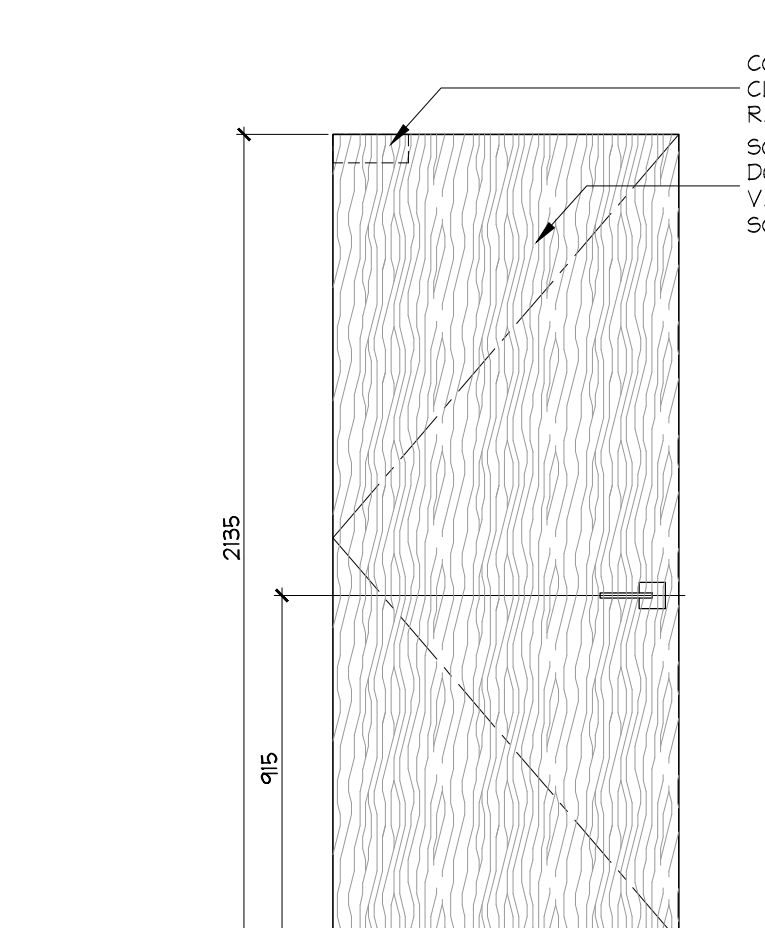

GROUND FLOOR DOOR 158, 158C THEATRE

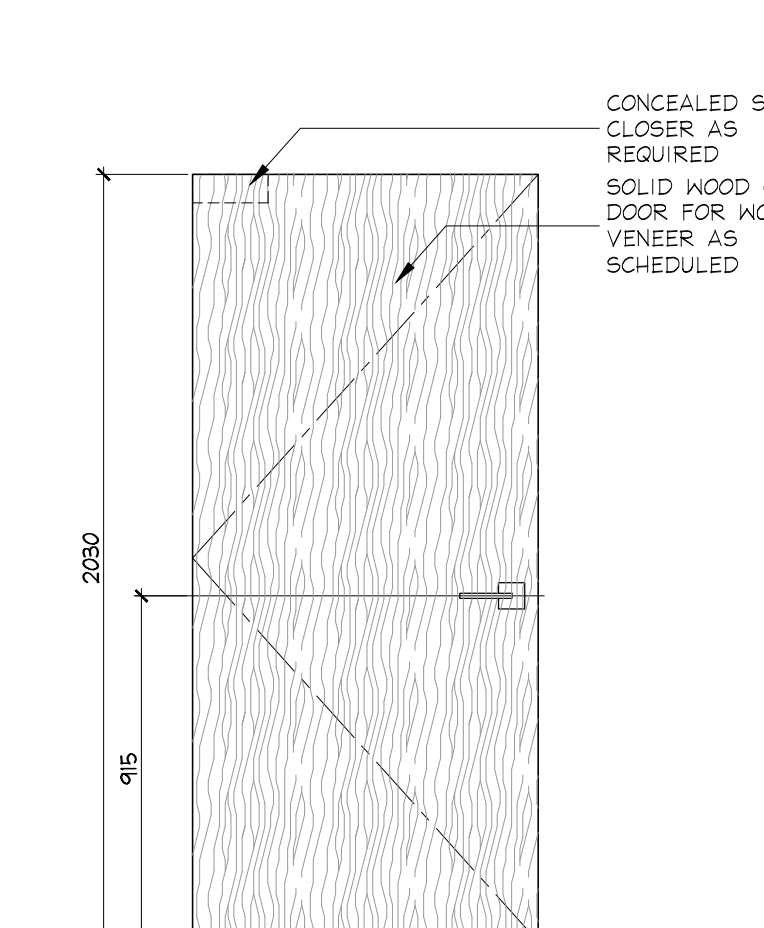

GROUND FLOOR DOORS 153A, 153B, 163A THEATRE / PARTY ROOM VFCU ACCESS PANEL

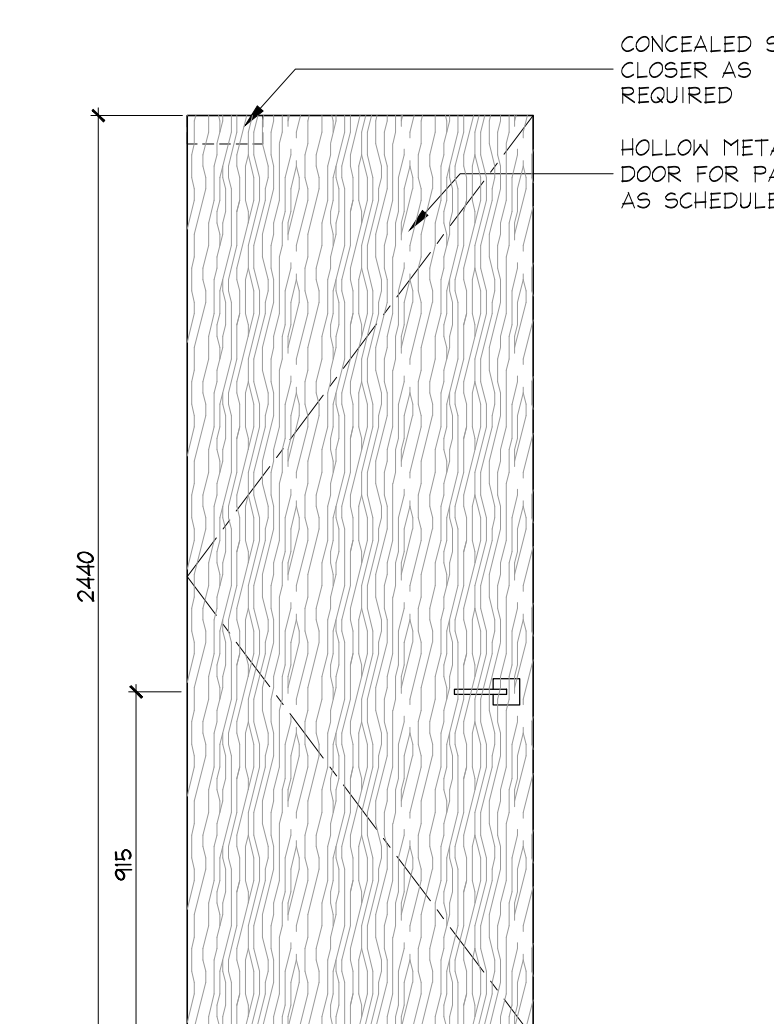

GROUND FLOOR DOOR 159 CORRIDOR D ELECTRICAL CLOSET

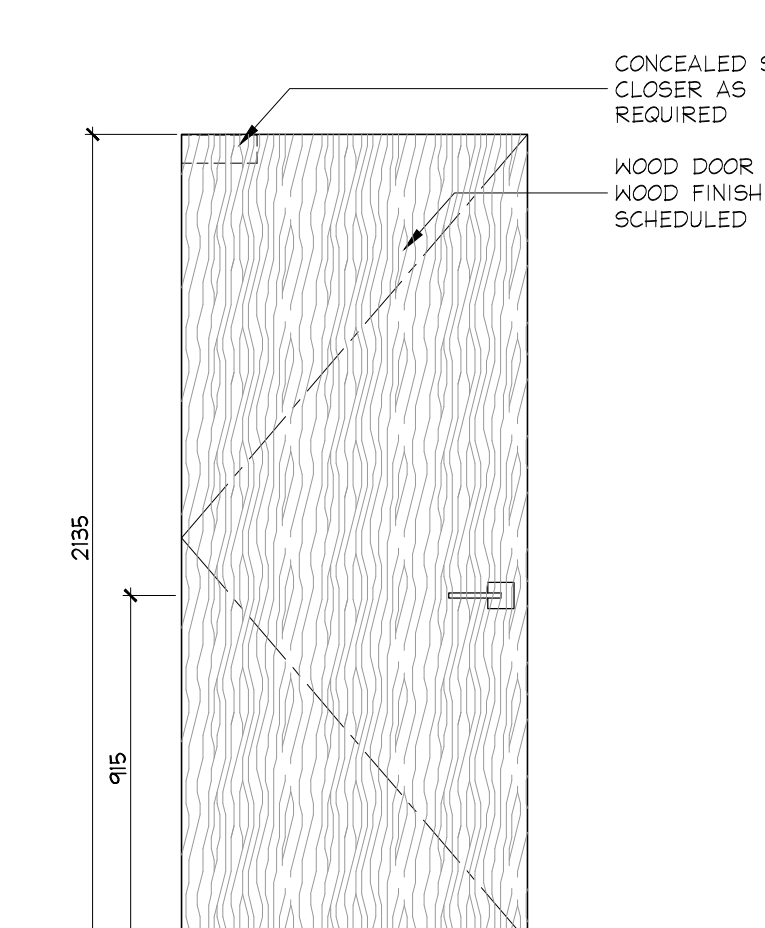

GROUND FLOOR DOOR 160.1 CORRIDOR C TO CORRIDOR A

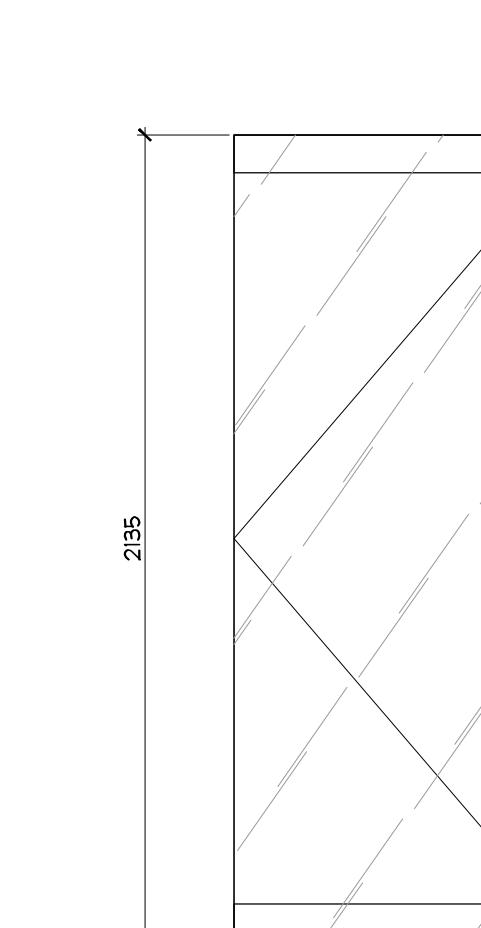

GROUND FLOOR DOOR 160.2, 164 PARTY ROOM AMENITY ENTRANCE PROPERTY MANAGEMENT OFFICE

02	26 JAN / 15	ISSUED FOR TENDER	AP
NO.	DATE	COMMENTS	INI
REVISIONS:			

UNION 31

UNION 31 INC.
183 BATHURST STREET, STE. 201
TORONTO, ON, M5T 2R7, CANADA
TEL: 416-597-1576 FAX: 416-597-2139

PROJECT NAME: ALEXANDRA PARK MAIN BUILDING	
BLOCK 11 ON, Canada	
PROJECT NO.:	13-949
DRAWINGS: DOOR ELEVATIONS	
DATE STARTED:	07 AUG / 13
SCALE:	AS NOTED
DRAWN BY:	SM
APPROVED BY:	KC
DRAWING NO.:	ID 2.4.0