

DO NOT SCALE DRAWINGS.

CONTRACTOR MUST VERIFY ALL DRAWINGS, DIMENSIONS, DETAILS AND SPECIFICATIONS, AND REPORT ANY DISCREPANCIES TO UNICORBI INC. BEFORE PROCEEDING WITH WORK. MATERIALS MAY NOT BE SUBSTITUTED WITHOUT WRITTEN APPROVAL FROM UNICORBI INC. ALL DRAWINGS AND SPECIFICATIONS ARE INSTRUMENTS OF SERVICE AND THE PROPERTY OF UNICORBI INC. WHICH MUST BE RETURNED AT THE COMPLETION OF THE WORK.

PRINTED: 24-Aug-15

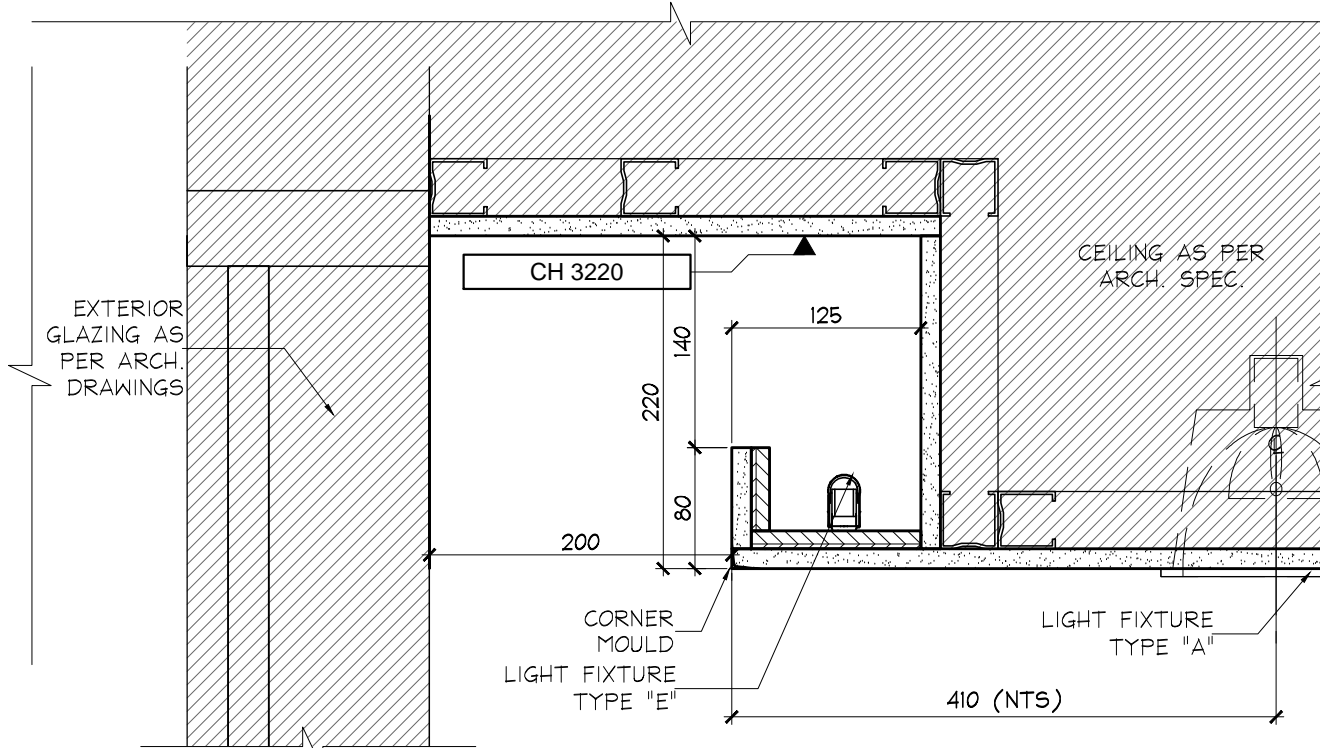

1 CEILING SECTION  
ID3.1.0 EAST VESTIBULE 1ST FLOOR SCALE 1:5

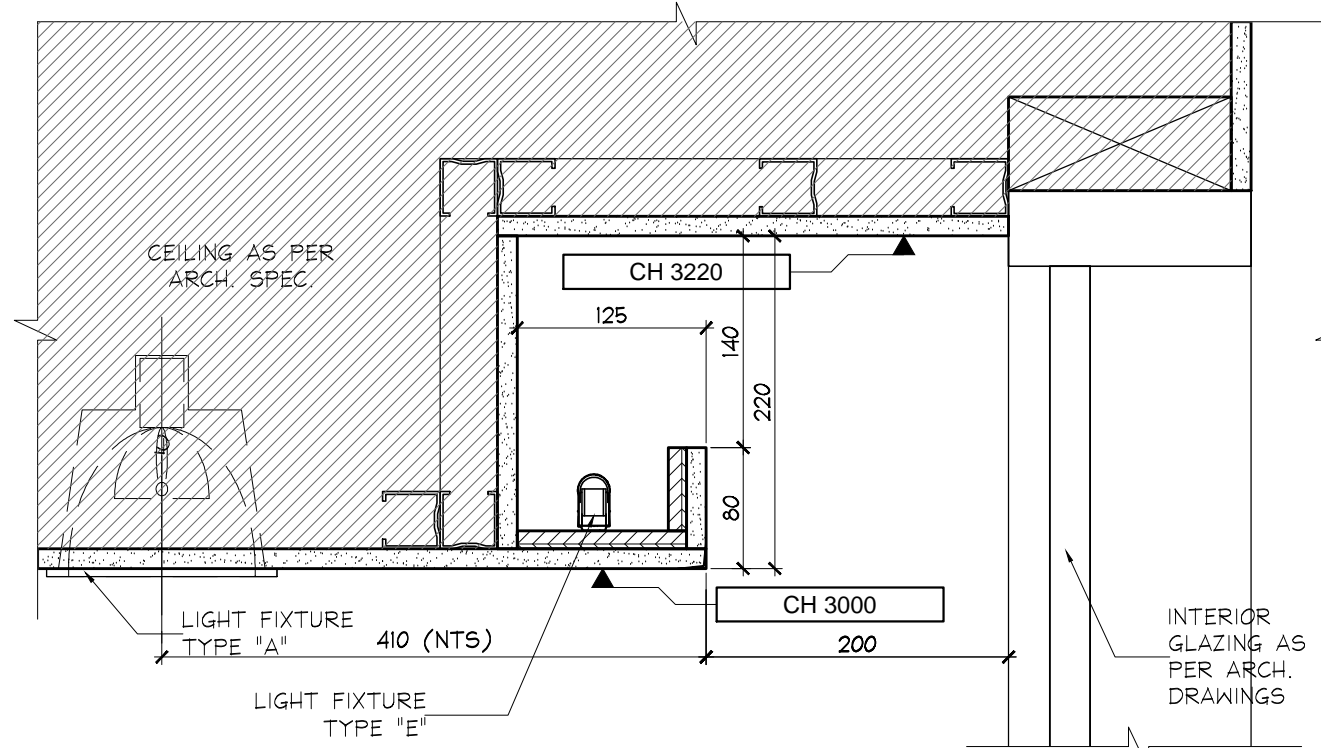

2 CEILING SECTION  
ID3.1.0 EAST VESTIBULE 1ST FLOOR SCALE 1:5

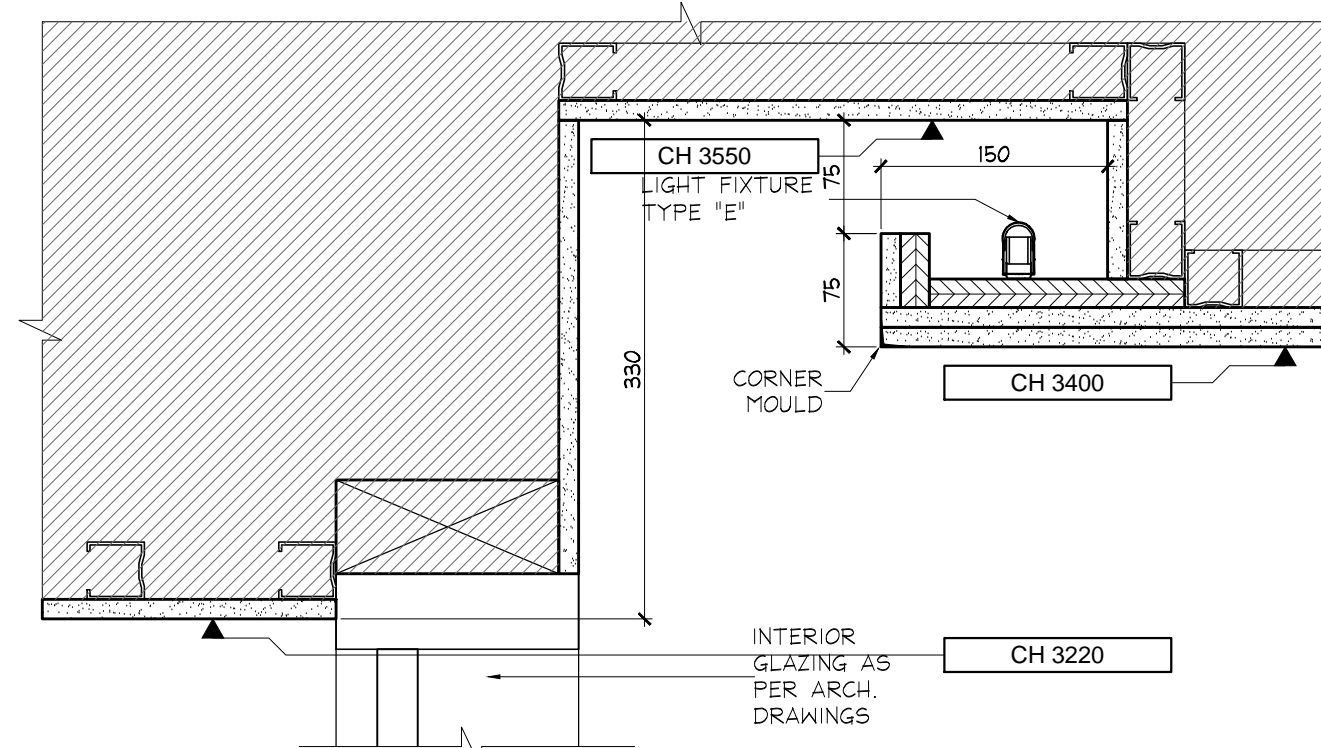

3 CEILING SECTION  
ID3.1.0 EAST VESTIBULE 1ST FLOOR SCALE 1:5

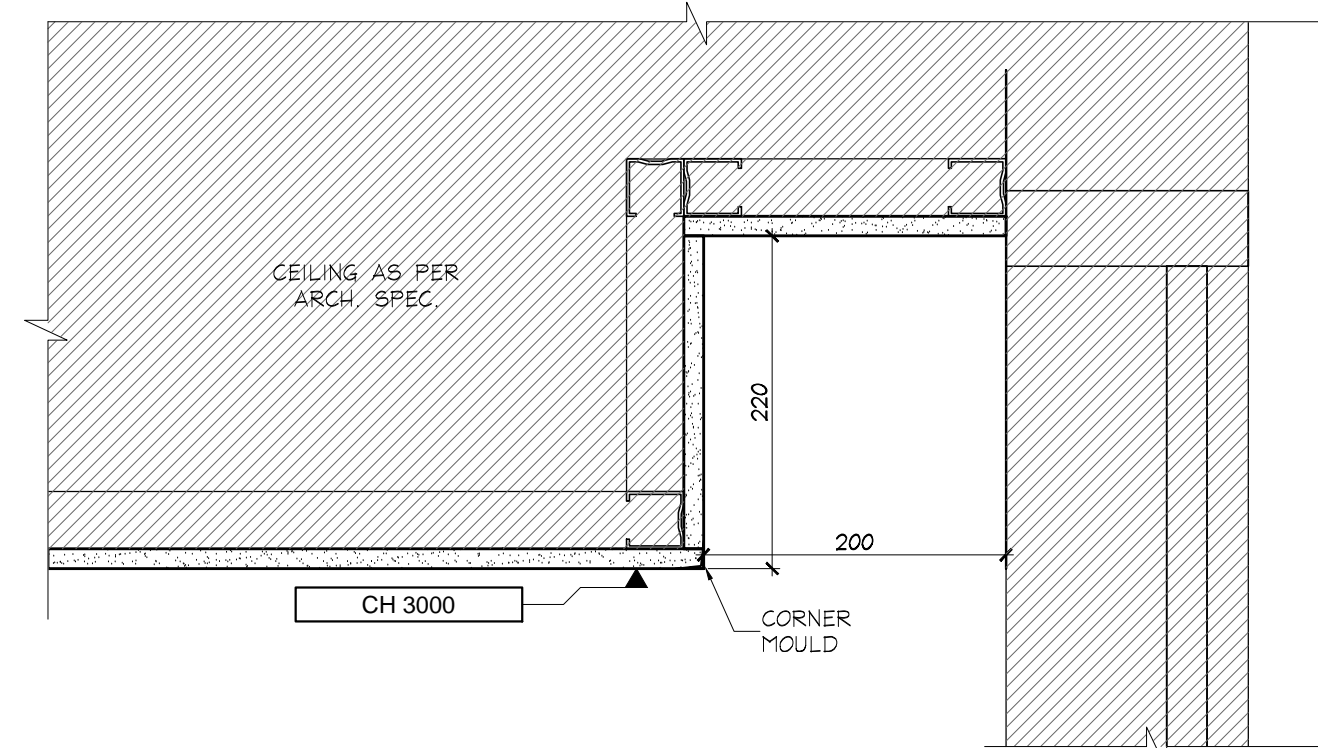

4 SECTION @ EXTERIOR GLAZ  
ID3.1.0 1ST FLOOR SCALE 1:5

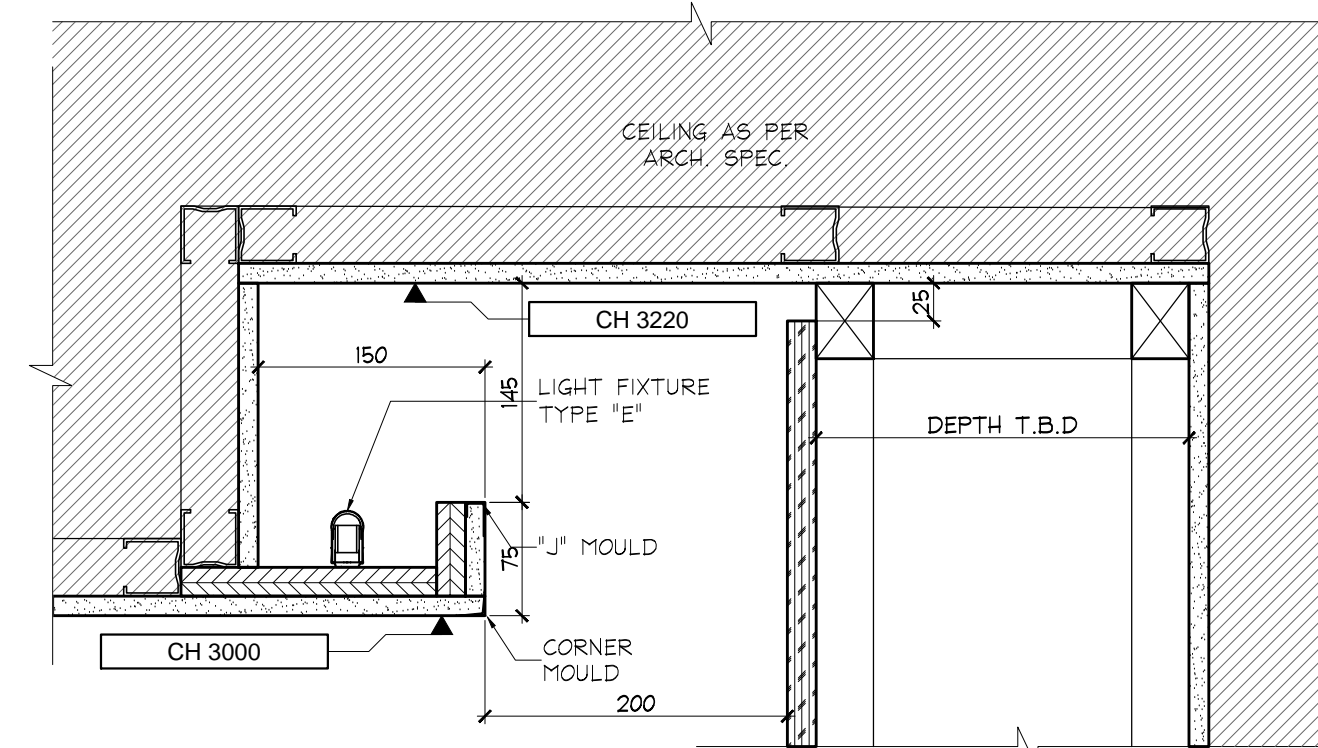

5 SECTION @ FIREPLACE  
ID3.1.0 1ST FLOOR SCALE 1:5

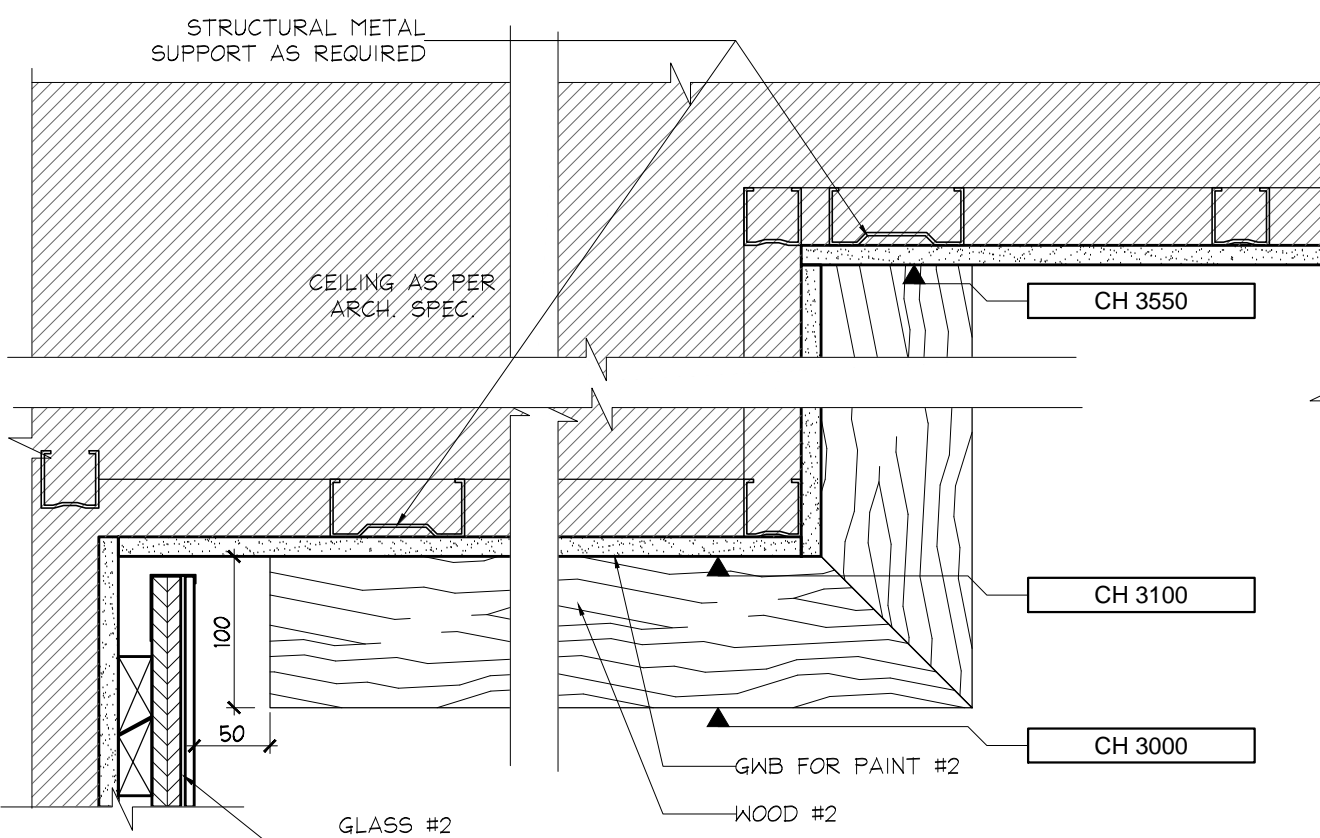

6 BULKHEAD @ CONCIERGE  
ID3.1.0 1ST FLOOR SCALE 1:5

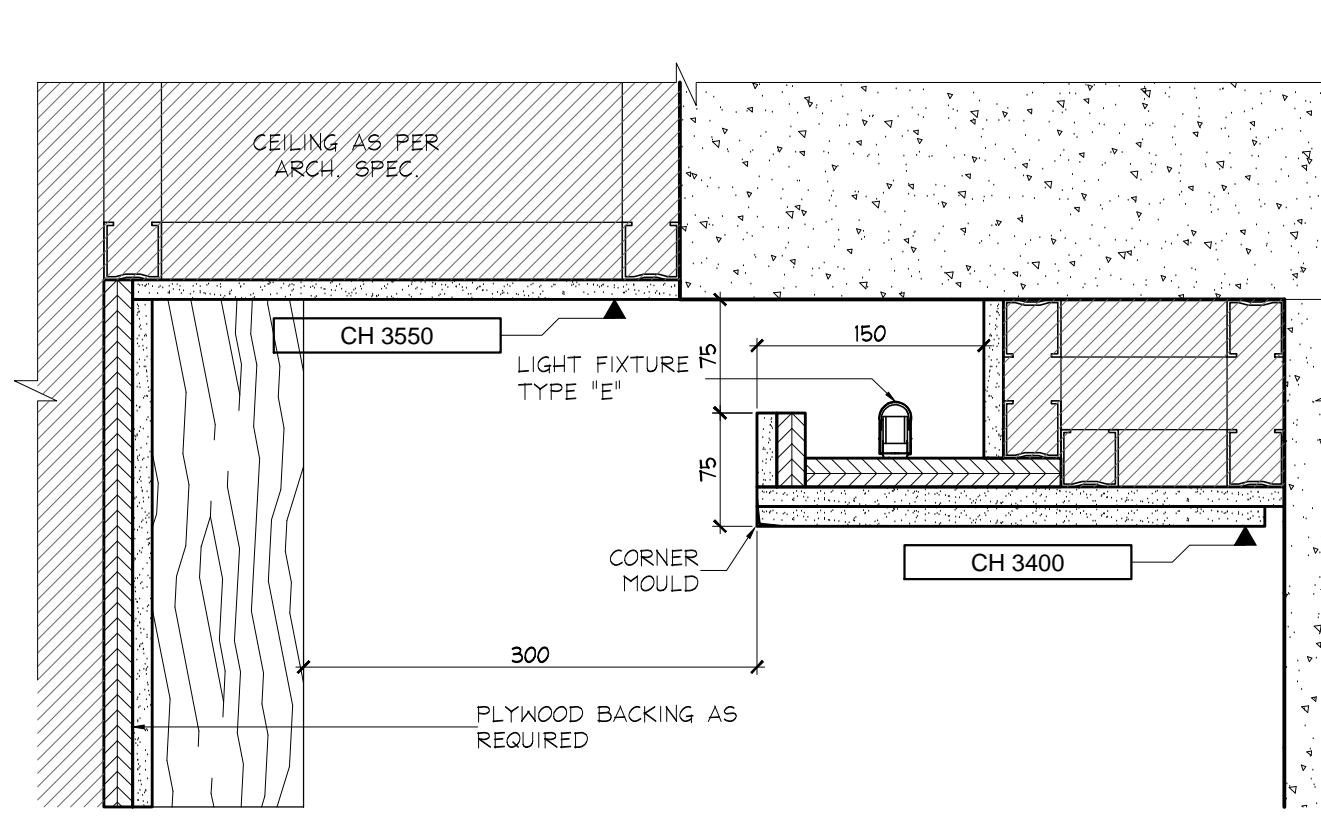

7 BULKHEAD @ CONCIERGE  
ID3.1.0 1ST FLOOR SCALE 1:5

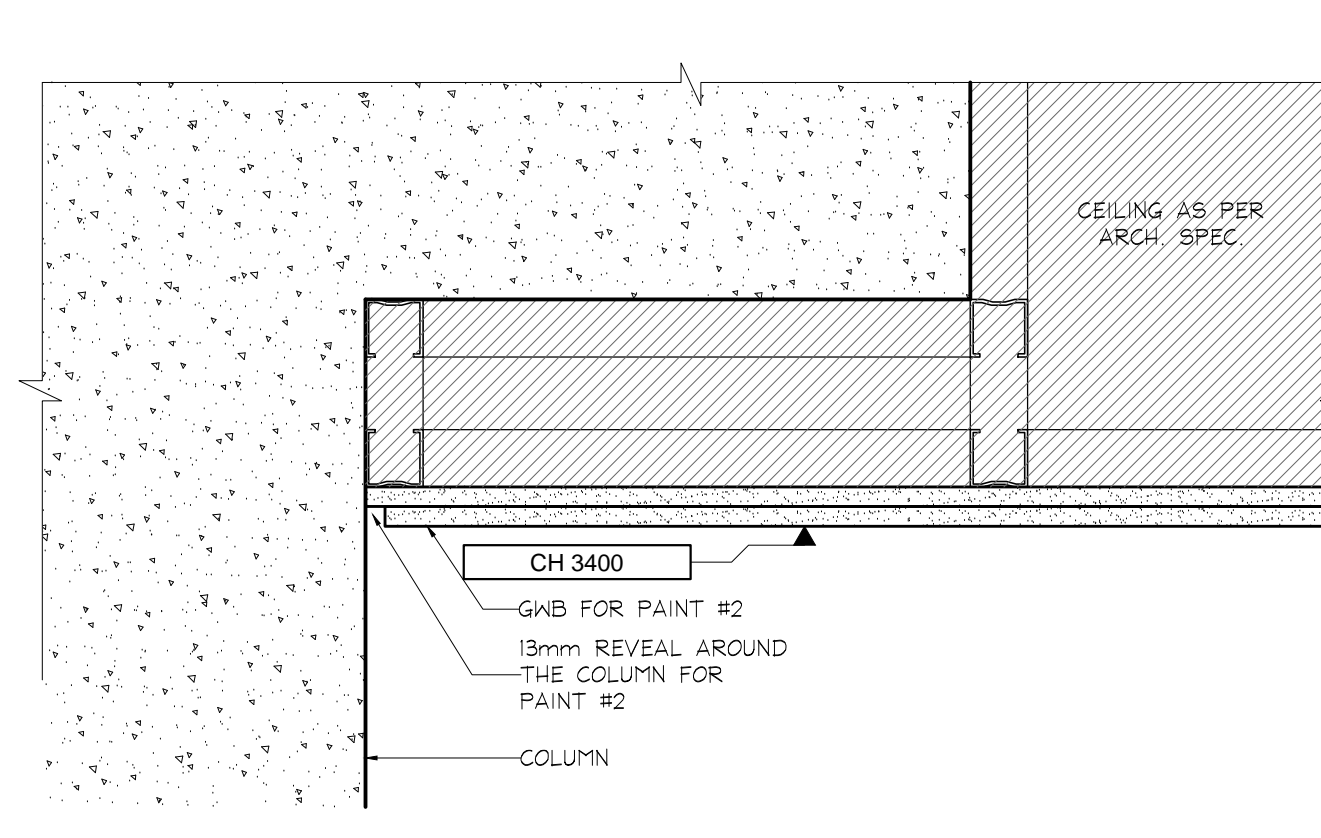

8 BULKHEAD @ CONCIERGE  
ID3.1.0 1ST FLOOR SCALE 1:5

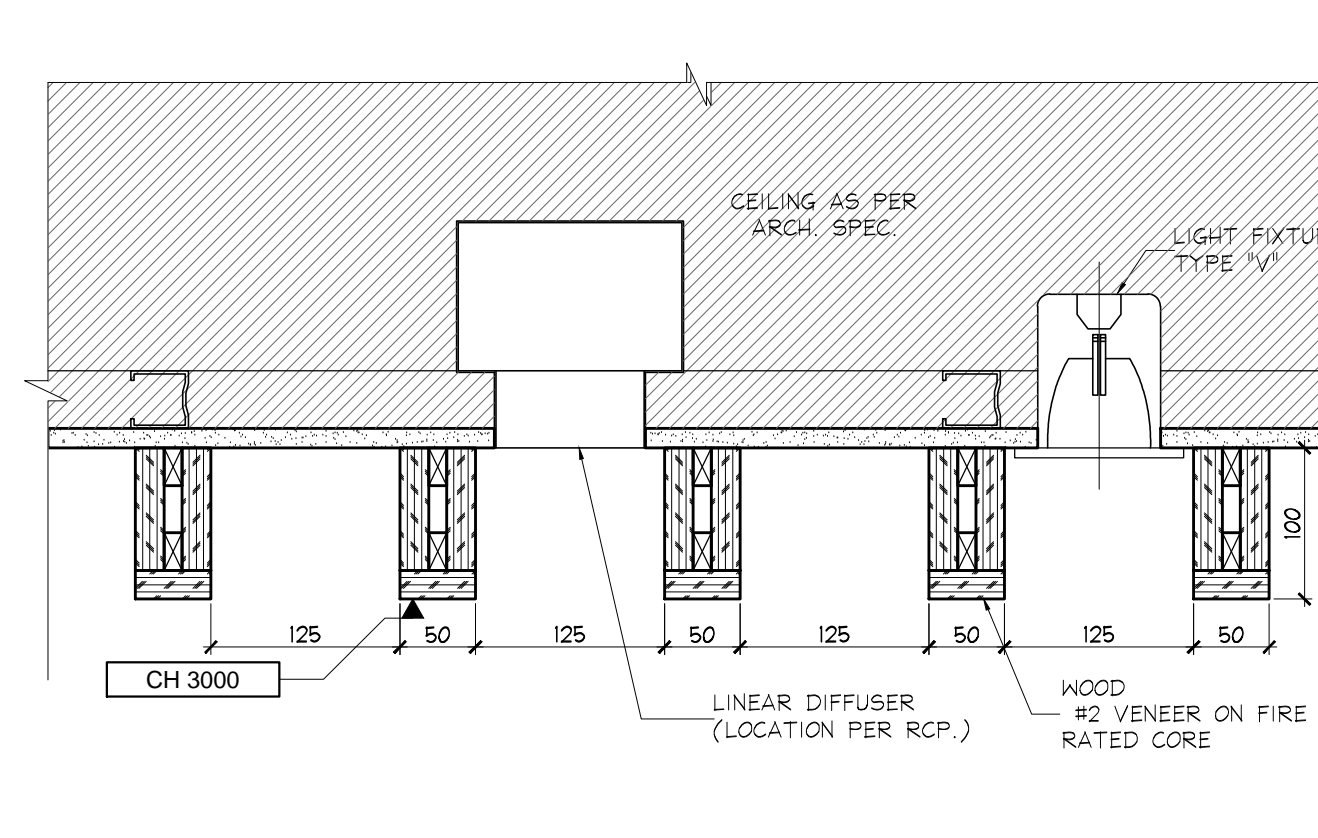

9 SECTION  
ID3.1.0 CEILING DETAIL @ CONCIERGE 1ST FLOOR SCALE 1:5

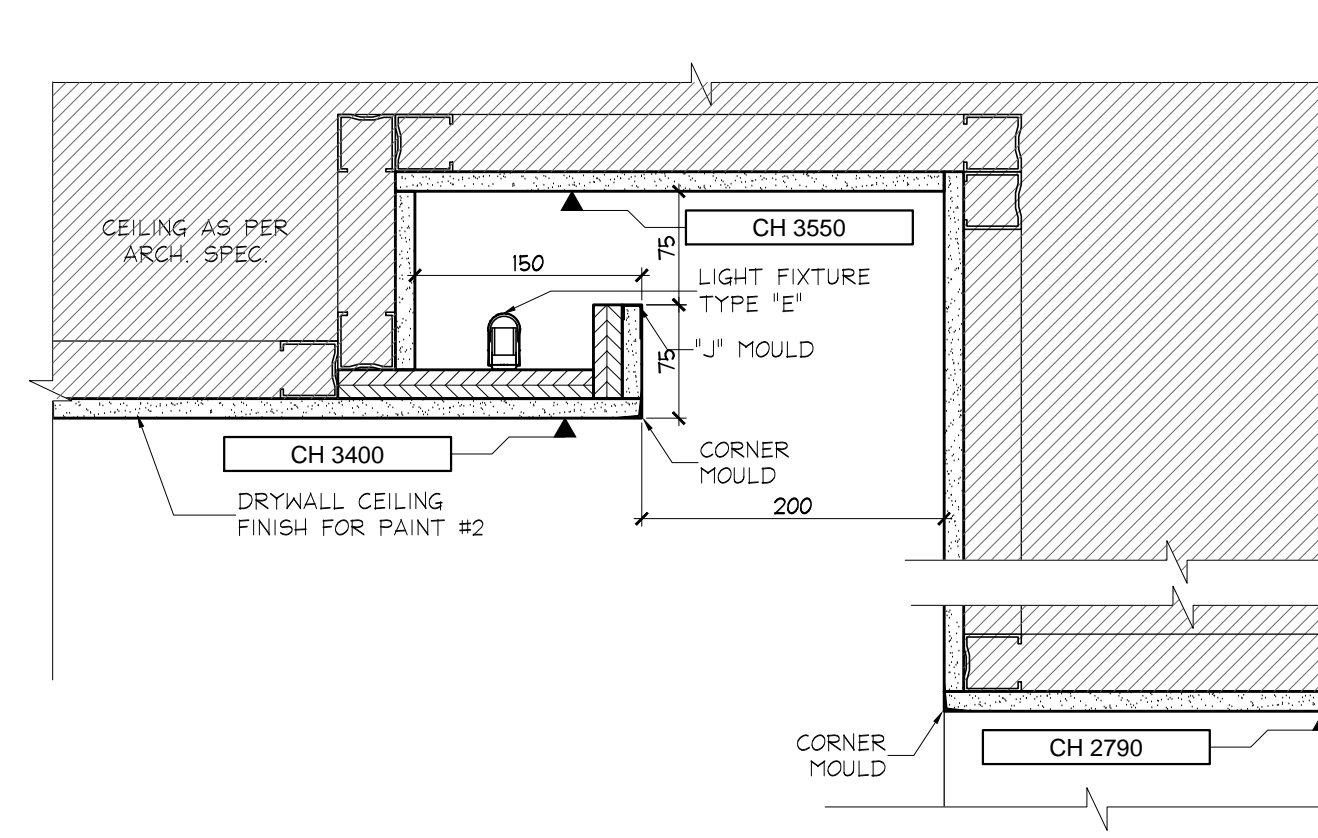

10 SECTION  
ID3.1.0 1ST FLOOR SCALE 1:5

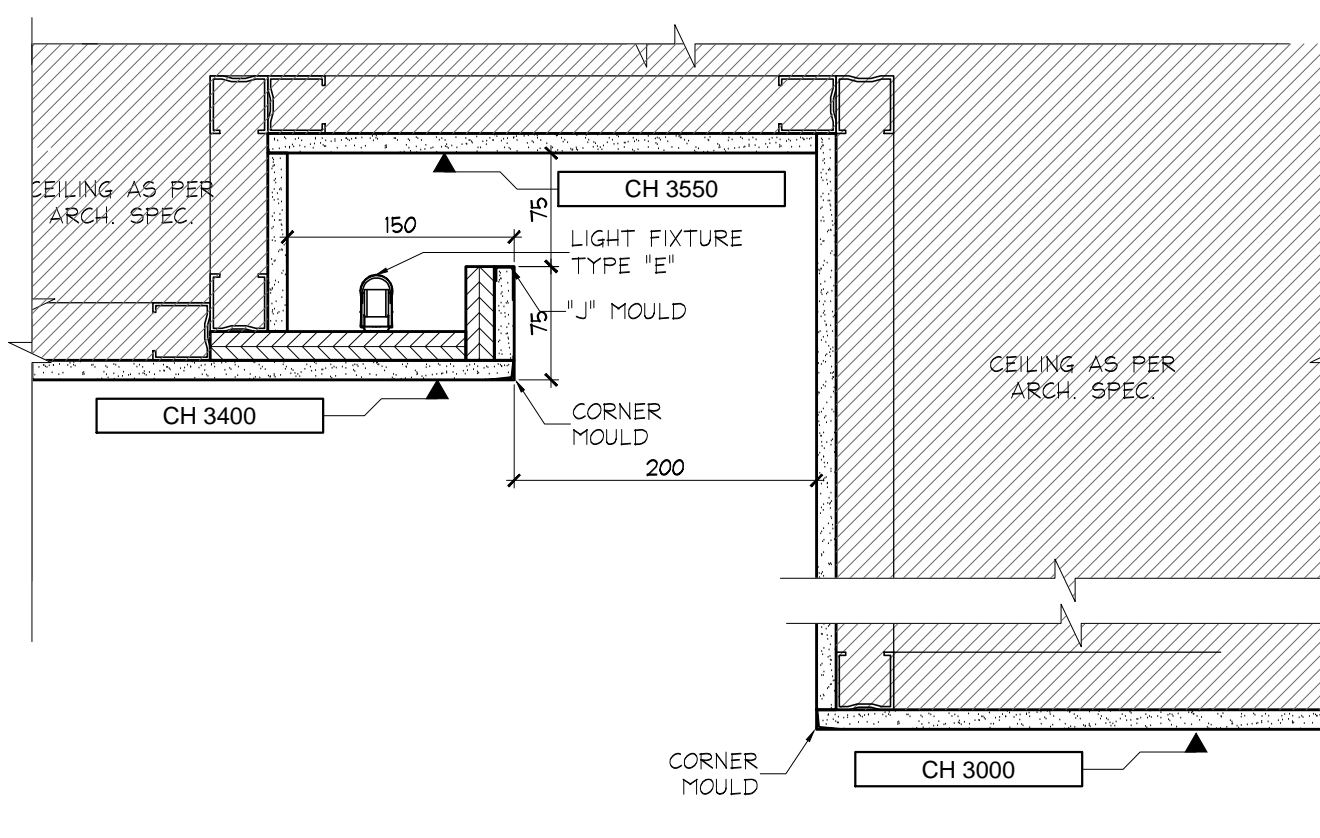

11 SECTION  
ID3.1.0 1ST FLOOR SCALE 1:5

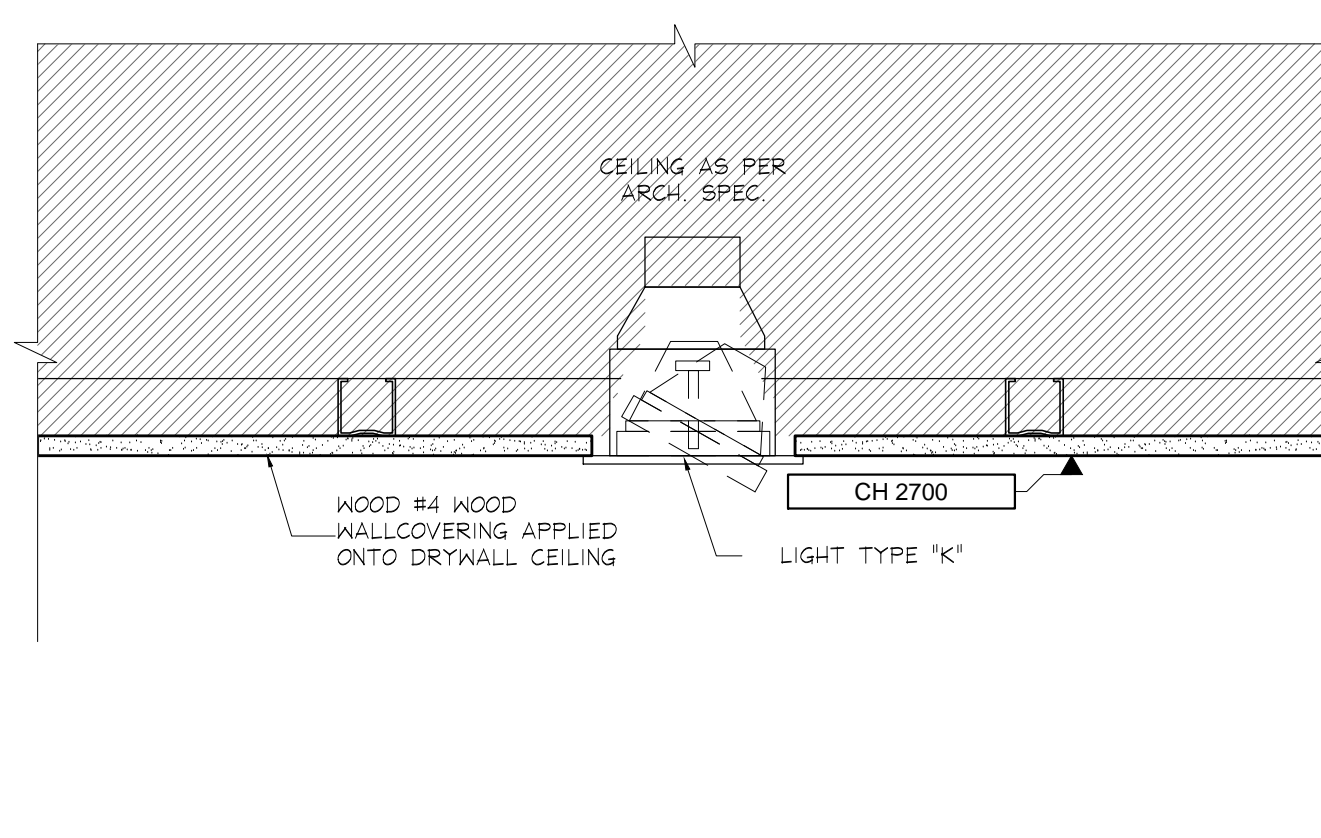

12 LIGHT DETAIL  
ID3.1.0 ELEVATOR LOBBY 1ST FLOOR SCALE 1:5

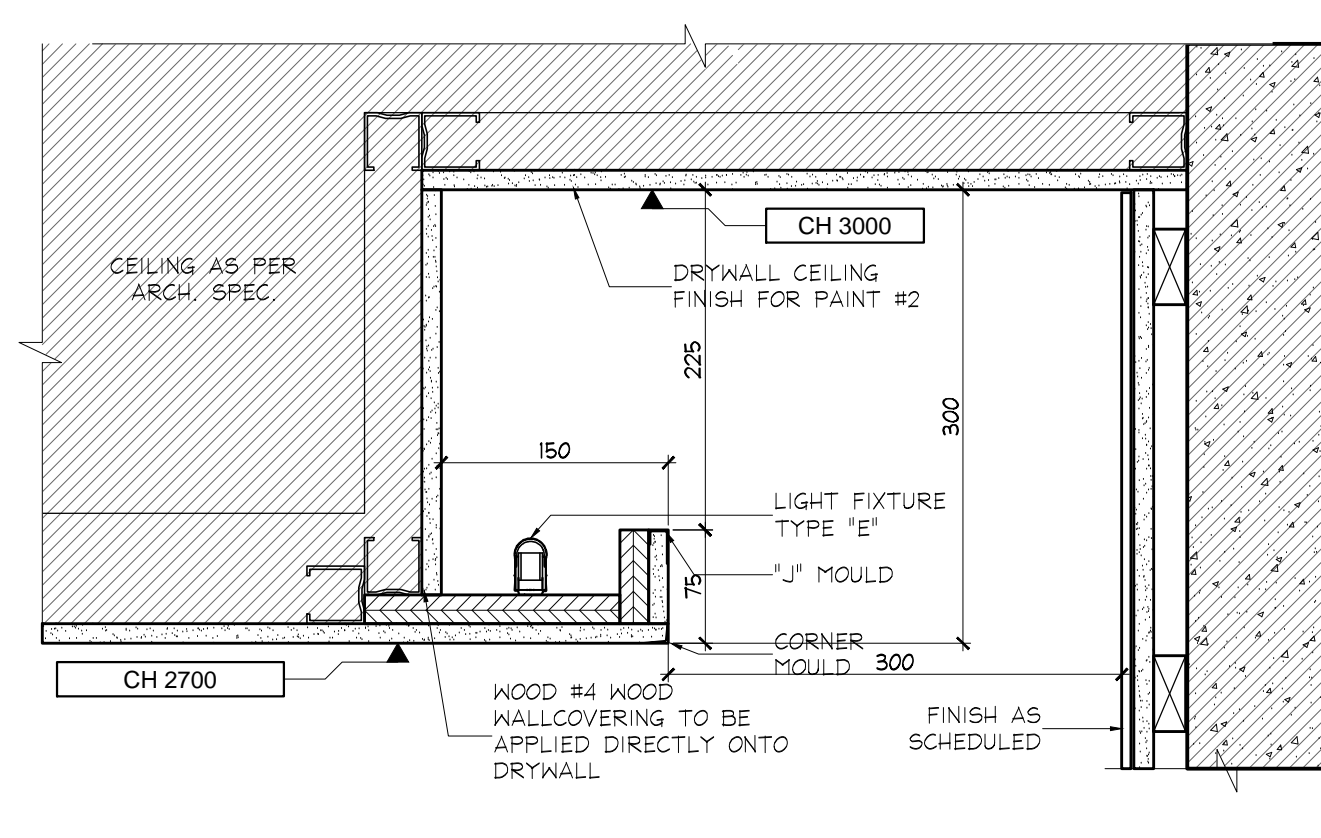

13 SECTION @ ELEVATOR COVE  
ID3.1.0 1ST FLOOR SCALE 1:5

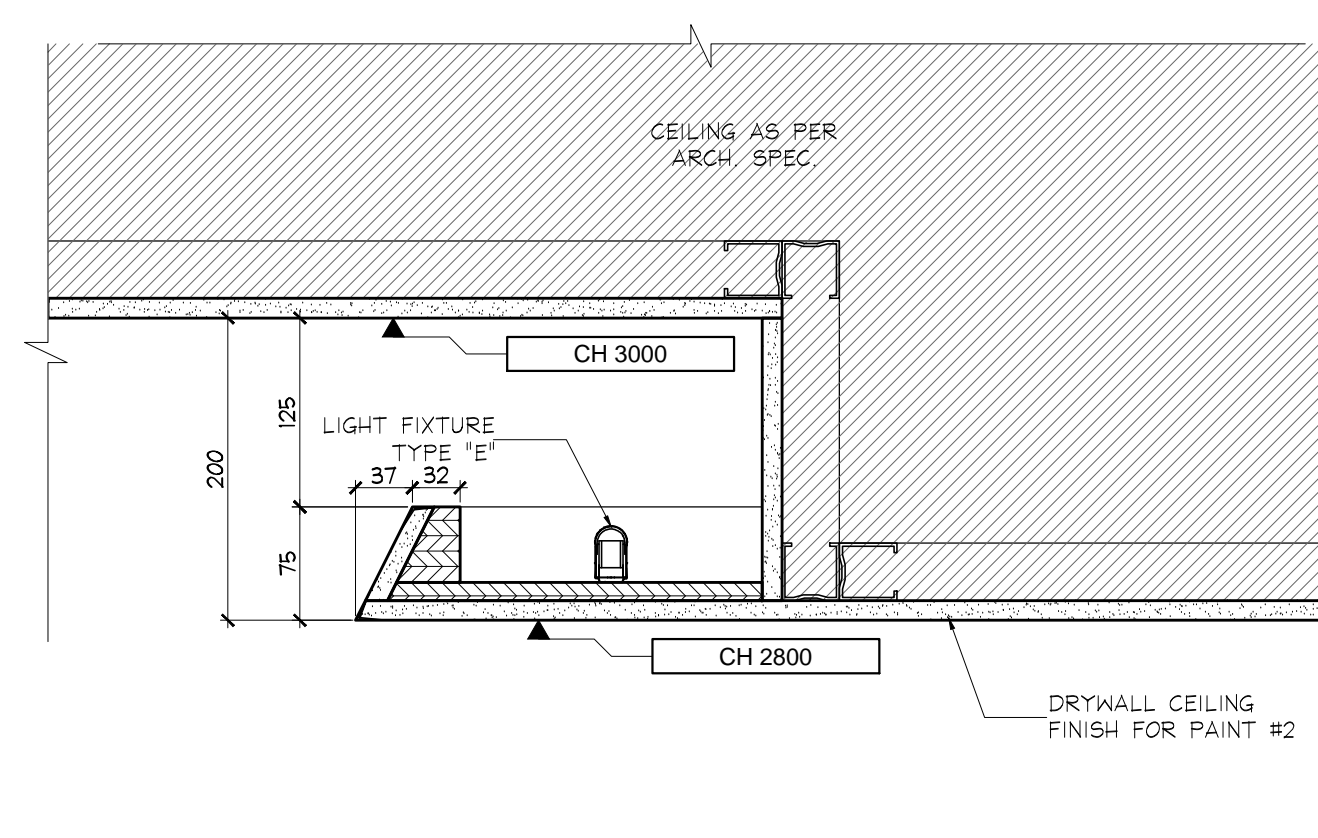

14 CEILING SECTION  
ID3.1.0 PARTY ROOM 1ST FLOOR SCALE 1:5

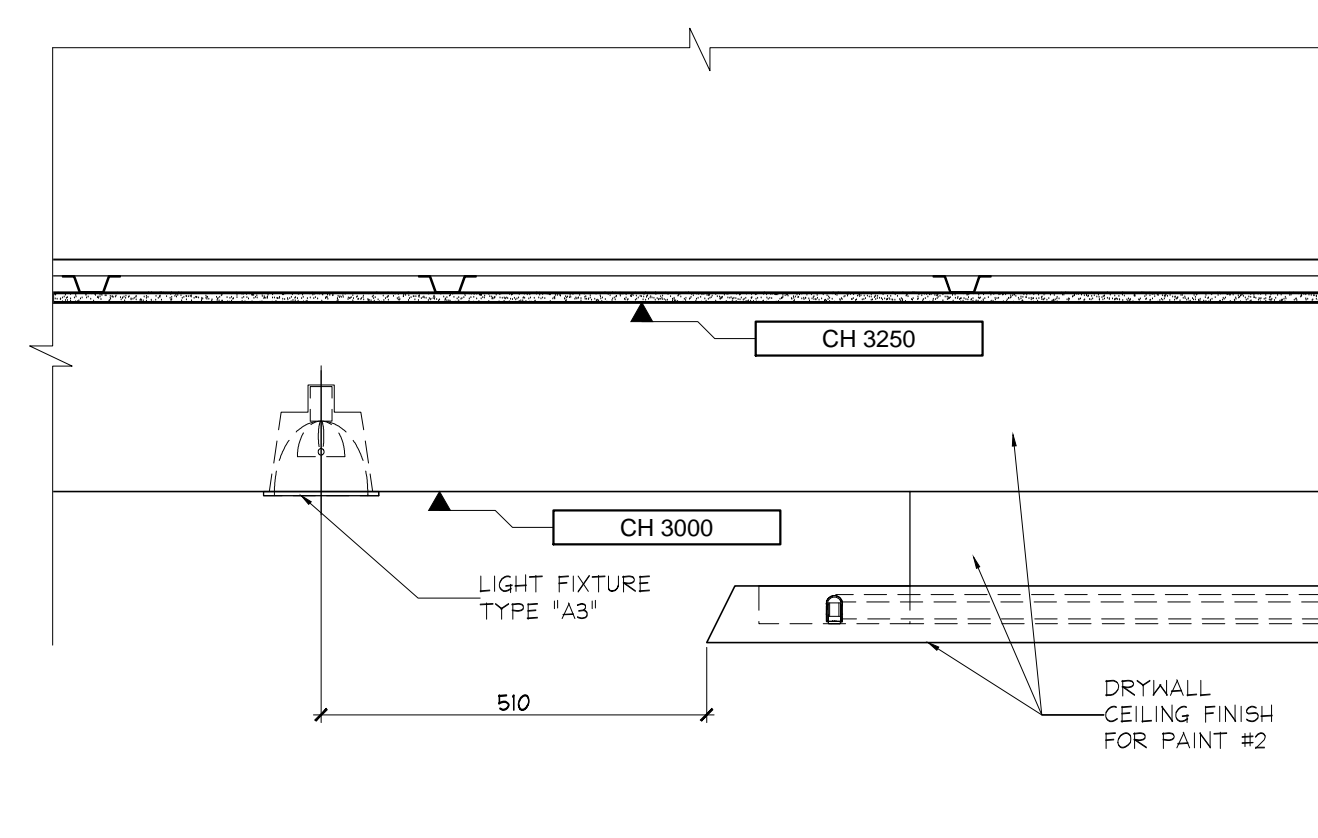

15 CEILING SECTION  
ID3.1.0 PARTY ROOM 1ST FLOOR SCALE 1:10

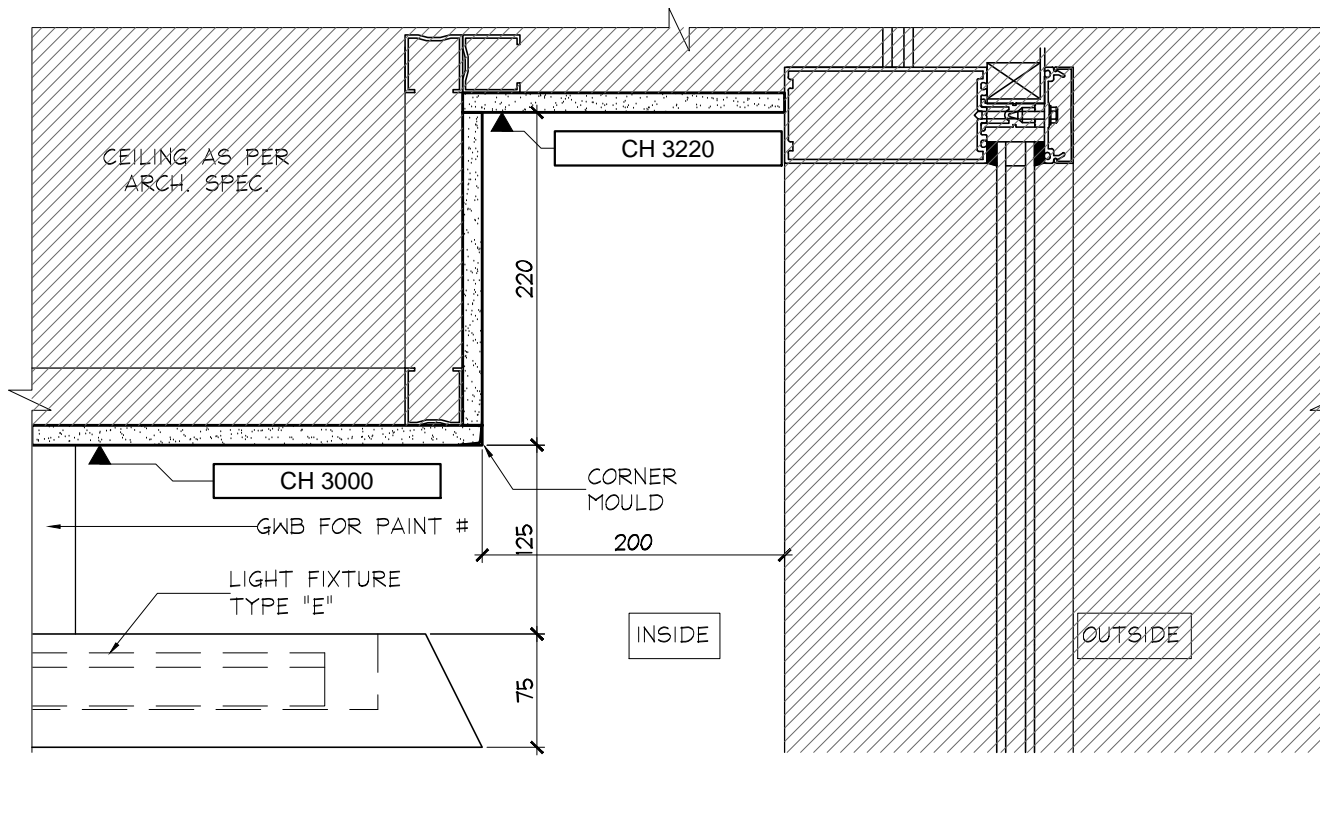

16 CEILING SECTION  
ID3.1.0 PARTY ROOM 1ST FLOOR SCALE 1:5

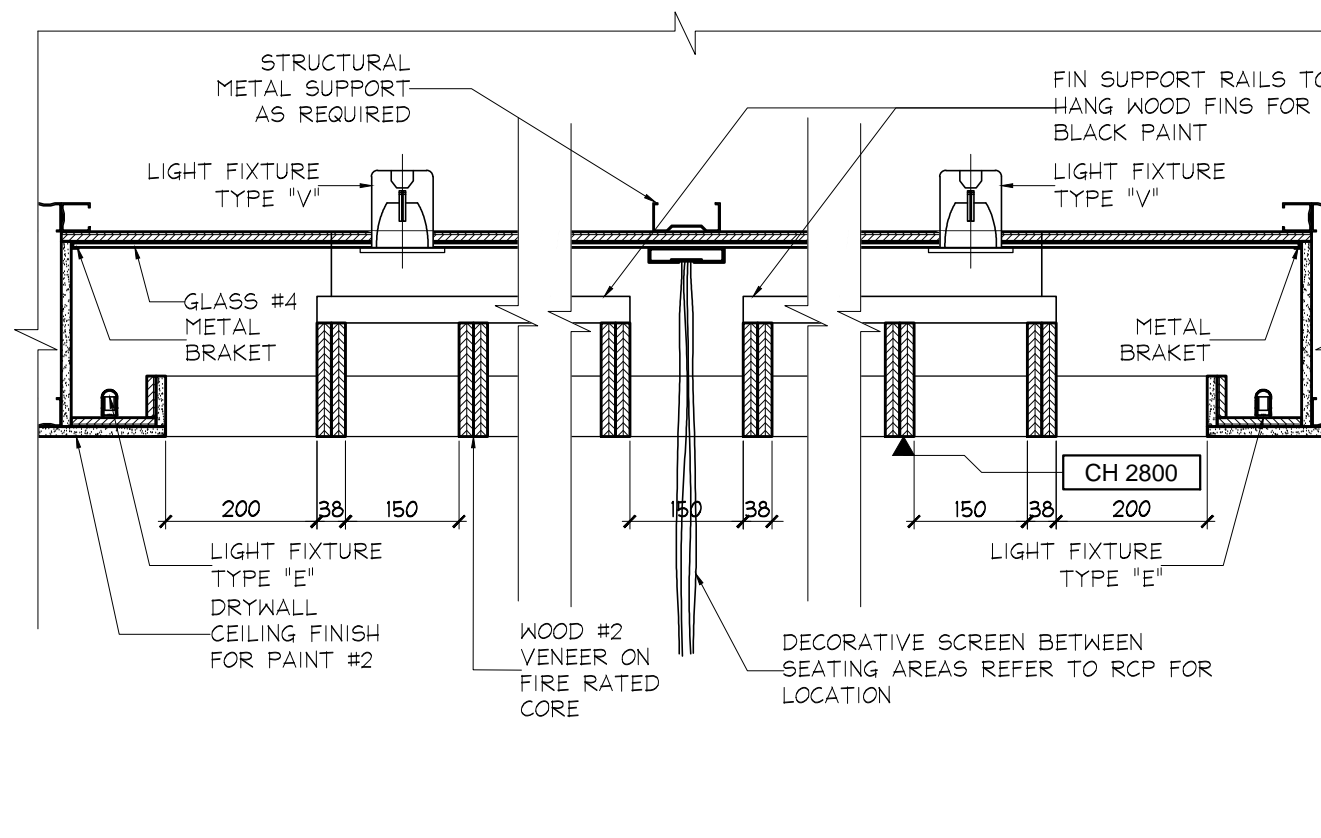

17 CEILING SECTION  
ID3.1.0 PARTY ROOM 1ST FLOOR SCALE 1:10

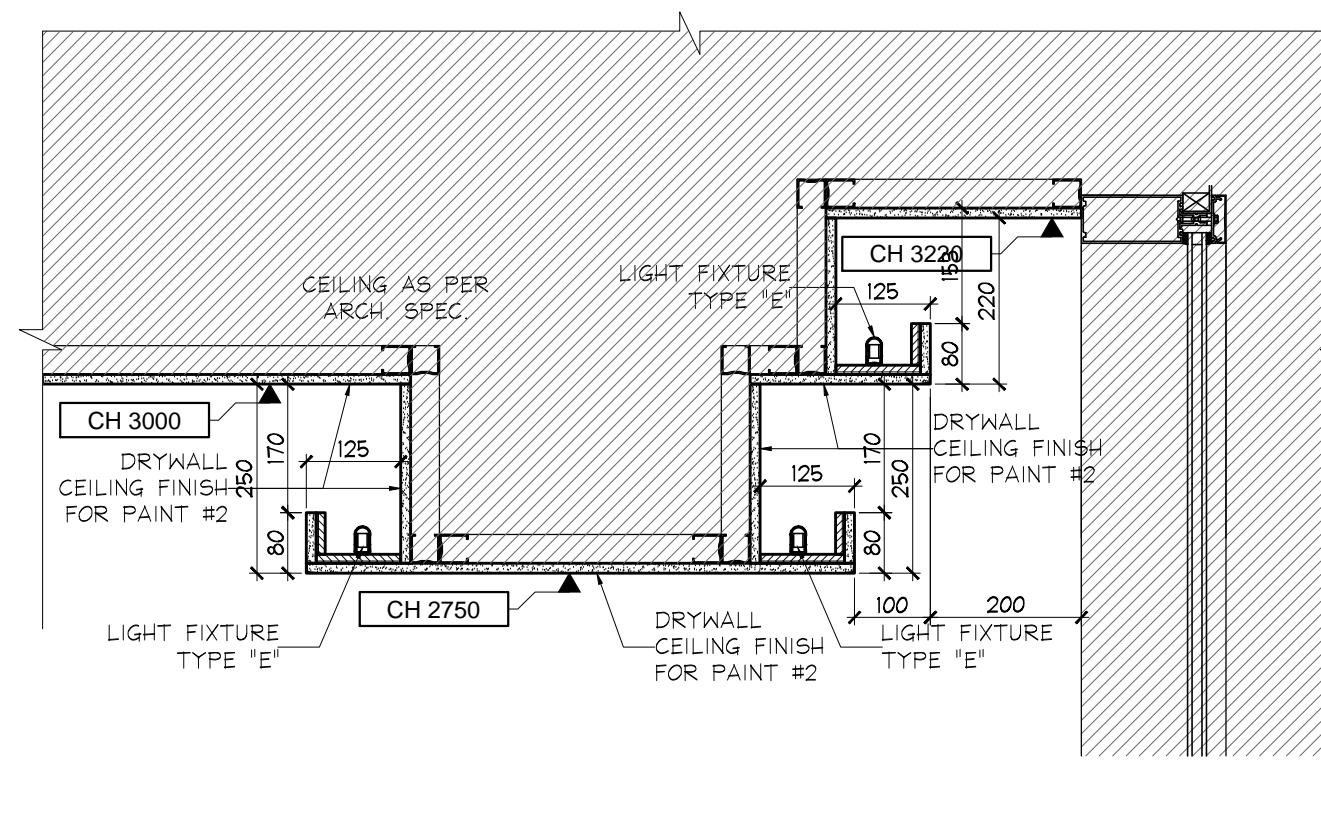

18 CEILING SECTION  
ID3.1.0 FITNESS AREA 1ST FLOOR SCALE 1:10

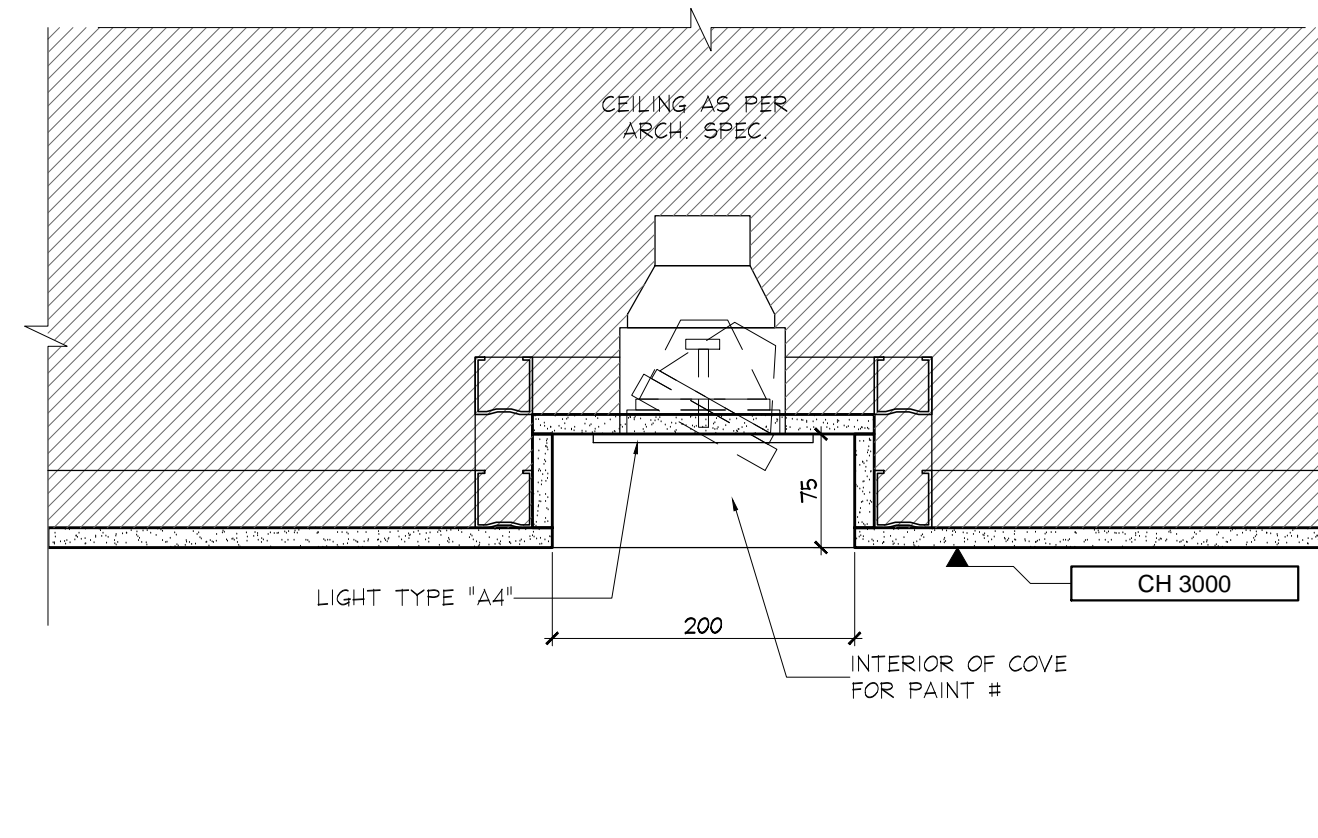

19 CEILING SECTION  
ID3.1.0 FITNESS AREA 1ST FLOOR SCALE 1:5

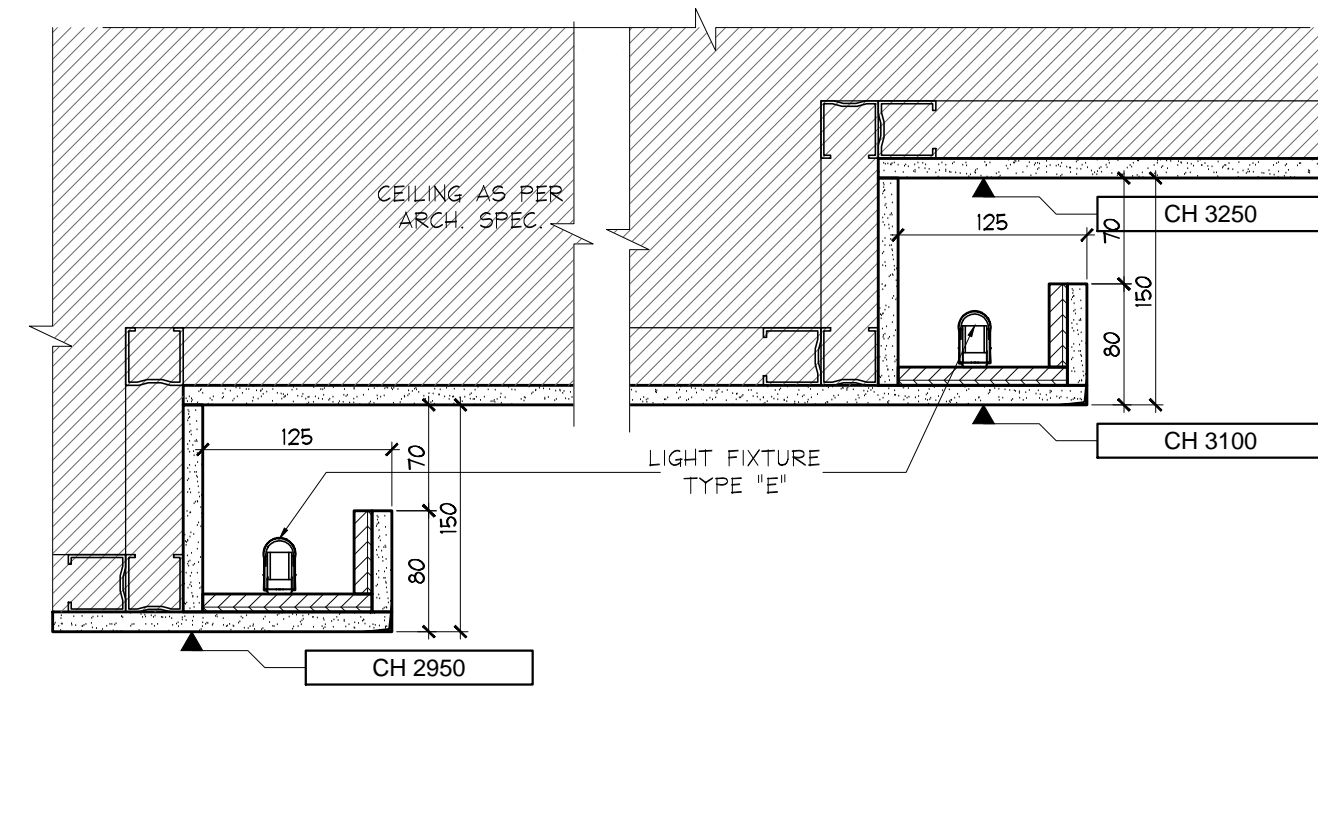

20 CEILING SECTION  
ID3.1.0 THEATRE 1ST FLOOR SCALE 1:5

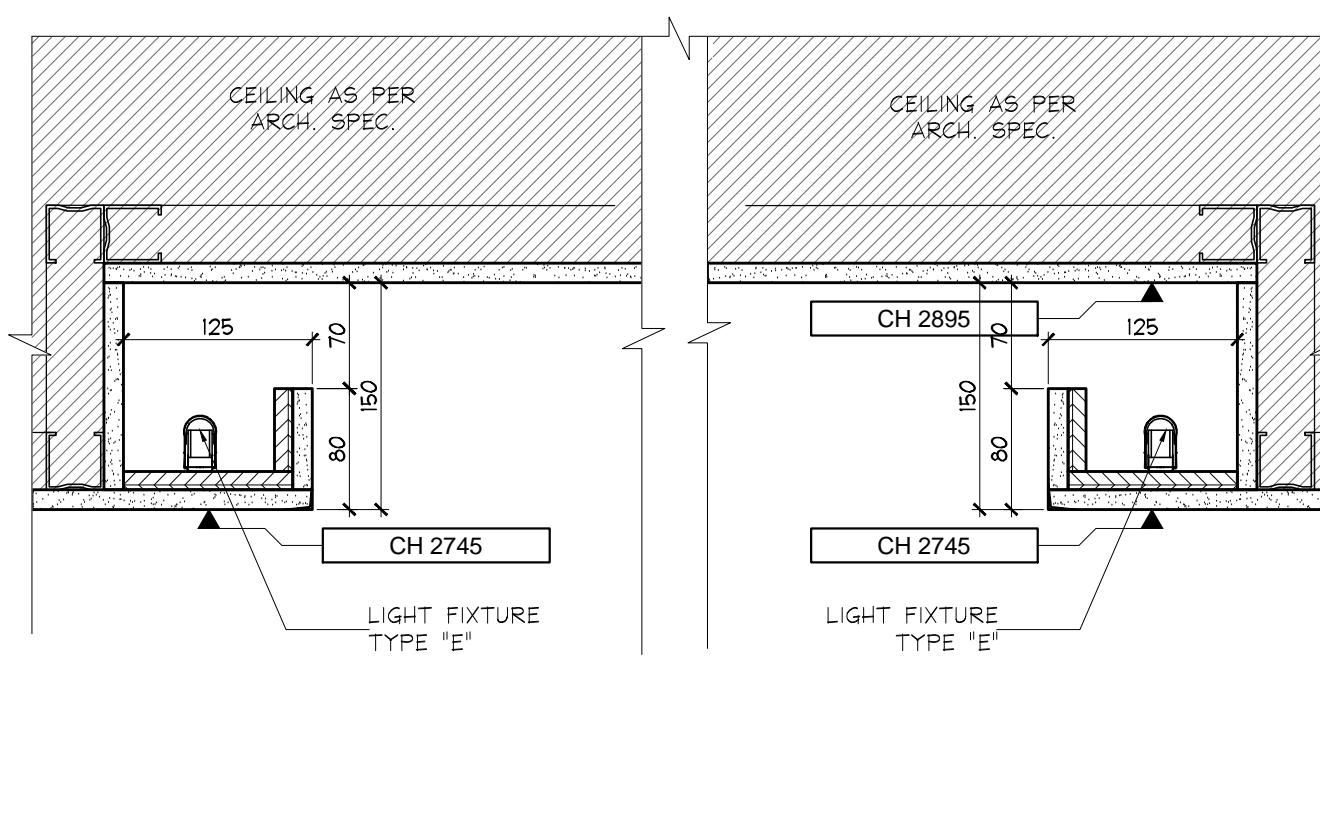

21 CEILING SECTION  
ID3.1.0 PROPERTY MANAGEMENT OFFICE 1ST FLOOR SCALE 1:5

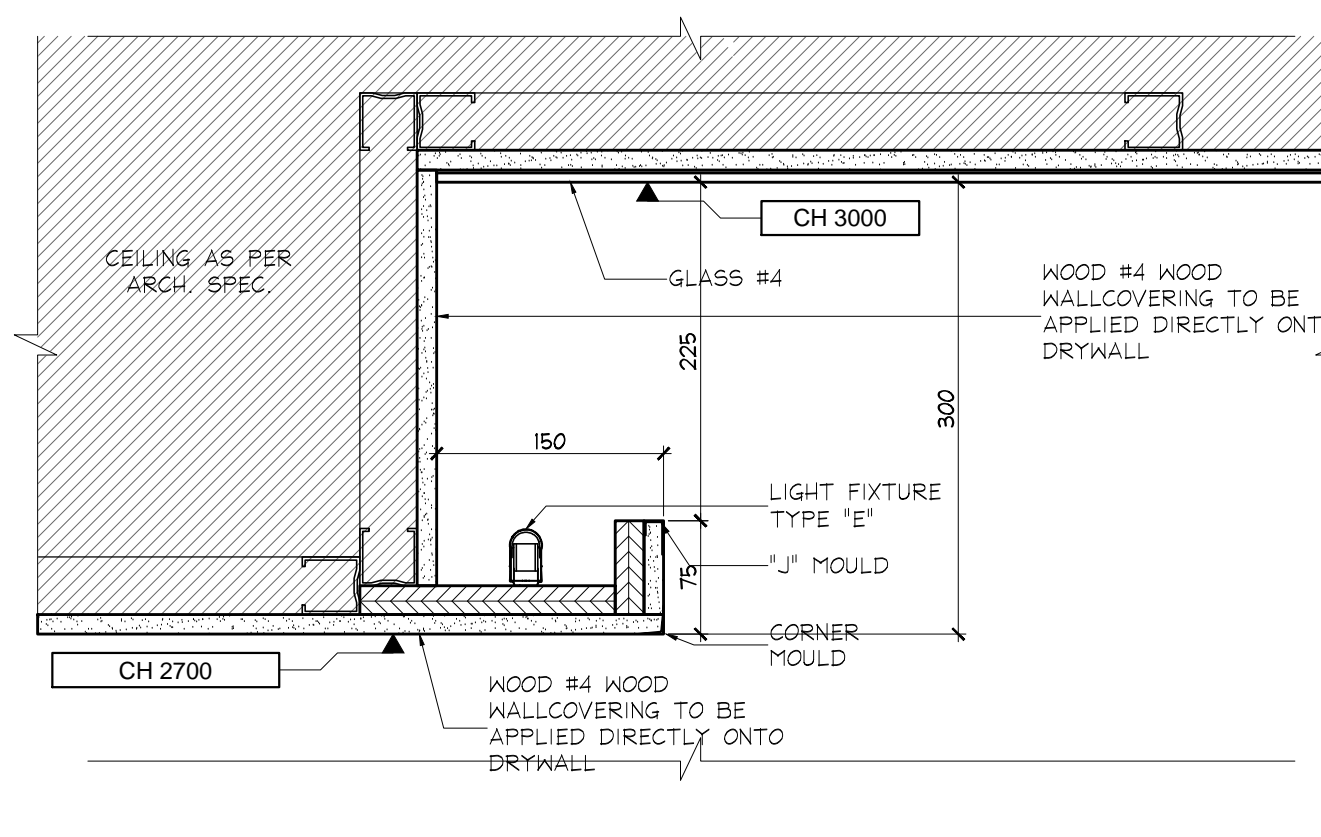

22 SECTION @ CORRIDOR 'D' COVE  
ID3.1.0 1ST FLOOR SCALE 1:5

NO	DATE	COMMENTS	INI
13	24 AUG / 15	RE- ISSUED FOR DRYWALL TENDER	CB
12	21 AUG / 15	ISSUED FOR TRIM CARPENTRY AND FINISH	CB
11	20 AUG / 15	ISSUED FOR DRYWALL TENDER	CB
10	15 JULY / 15	ISSUED FOR TRIM CARPENTRY TENDER	CB
09	16 JUNE / 15	ISSUED FOR FINISH CARPENTRY	CB
03	08 MAR / 15	ISSUED FOR TILE TENDER	AP
02	26 JAN / 15	ISSUED FOR TENDER	AP
01	22 AUG / 14	ISSUED FOR PERMIT	AP

**UNICORBI**

UNICORBI INC.  
183 BATHURST STREET, STE. 201  
TORONTO, ON, M5T 2R7, CANADA  
TEL: 416-597-1576 FAX: 416-597-2139

PROJECT NAME:	ALEXANDRA PARK MAIN BUILDING
BLOCK:	11
ON, Canada	
PROJECT NO.:	13-949
DRAWINGS:	CEILING DETAILS
DATE STARTED:	07 AUG / 13
SCALE:	AS NOTED
DRAWN BY:	GG
APPROVED BY:	KC
DRAWING NO.:	ID
	3.1.0