

FOUNDATION PLAN (PARKING LEVEL P2)

SCALE 1 : 100

1. REFER TO GEOLOGICAL REPORT BY TORONTO INSPECTION LTD. FOR SOIL BEARING PRESSURE S15=400 KPa S2=700 KPa
2. PILES SHALL BE 400mm Ø, DRILLED 1.5m INTO THE SHALE BEDROCK (APPROX. AT 7% θ) AS NOTED IN THE GEO. REPORT WITH AN ASSUMED WORKING LOAD OF 8000 kN
3. TOP OF PILE CAPS ARE 300 MIN. FROM TOP OF FINISHED SLAB. FINISHED SLAB BEING 150mm
4. CONCRETE STRENGTH AT 28 DAYS SHALL BE AS FOLLOWS:
 REINFORCED CONCRETE FOR FOUNDATION WALLS — 30 MPa, EXPOSURE CLASS F2;
 REINFORCED CONCRETE FOR PILES — 30 MPa, EXPOSURE CLASS F2;
 CONCRETE FOR WALLS — 30 MPa, EXPOSURE CLASS F2;
 SEE SCHEDULES
5. MINIMUM YIELD STRESS FOR REINFORCING STEEL SHALL BE 400 MPa. HAVE 6% TO 8% ENRICHED AIR.
6. SLAB ON GRADE SHALL BE 100mm THICK, REINFORCED WITH FIBRILATED POLYPROPYLENE FIBERS, UNLESS OTHERWISE NOTED ON PLAN. SLAB ON GRADE SHALL BE 200mm THICK, REINFORCED WITH FIBRILATED POLYPROPYLENE FIBERS, UNLESS OTHERWISE NOTED ON PLAN.
7. SLAB ON GRADE SHALL BE 100mm THICK, REINFORCED WITH FIBRILATED POLYPROPYLENE FIBERS, UNLESS OTHERWISE NOTED ON PLAN. SLAB ON GRADE SHALL BE 200mm THICK, REINFORCED WITH FIBRILATED POLYPROPYLENE FIBERS, UNLESS OTHERWISE NOTED ON PLAN.
8. SEE TYPICAL DETAILS ON DRAWINGS S-101 TO S-106.
9. SEE GENERAL NOTES ON DRAWING S-101
10. SEE COLUMN & WALL SCHEDULE ON DRAWINGS S-101 TO S-106.
11. SEE ARCH. DRAWINGS FOR EXACT FLOOR SLOPES & ELEVATIONS.
12. S.O.F. DENOTES STEP DOWN FOOTING.
13. PROVIDE 25mm OF RIGID INSULATION UNDER SLAB ADJACENT TO LOWER LEVEL.
14. VERIFY ELEVATOR PIT DEPTH WITH ELEVATOR MANUFACTURER.
15. LOWER FOOTINGS AS NECESSARY FOR INSTALLATION.
16. VERIFY MECH. PITS WITH MECHANICAL DRAWINGS.
17. SEE TYPICAL DETAILS FOR REBAR SUMP PITS.
18. CENTRE LINE OF PILE CAP IS THE CENTRE LINE OF COLUMN OR SHEAR WALL UNLESS OTHERWISE NOTED ON PLAN.
19. SEE ARCHITECTURAL DRAWINGS FOR LOCATIONS AND SIZES OF ALL CONCRETE CURBS. SEE TYPICAL DETAILS FOR REINFORCING.

TYPICAL PILE CAP FOR COLUMNS

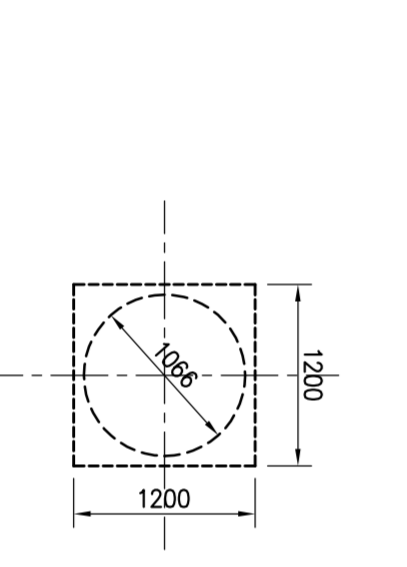

TYPICAL GRADE BEAM FOR WALLS

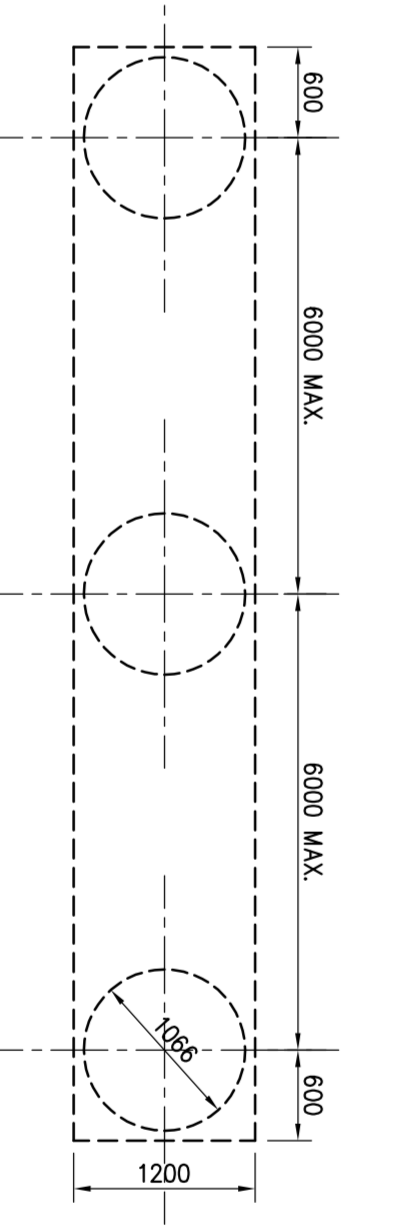

FIRST FLOOR ELEV. 83.000m

NO.	REVISION	DATE
1	ISSUED FOR PERMIT	2014/03/14
2	REVISED FOR COMMENTS	2014/03/27
3	REVISED FOR COMMENTS	2014/04/02
4	REVISED FOR COMMENTS	2014/04/02
5	REVISED FOR COMMENTS	2014/04/02
6	REVISED FOR COMMENTS	2014/04/02
7	REVISED FOR COMMENTS	2014/04/02
8	REVISED FOR COMMENTS	2014/04/02
9	REVISED FOR COMMENTS	2014/04/02
10	REVISED FOR COMMENTS	2014/04/02
11	REVISED FOR COMMENTS	2014/04/02
12	REVISED FOR COMMENTS	2014/04/02
13	REVISED FOR COMMENTS	2014/04/02
14	REVISED FOR COMMENTS	2014/04/02
15	REVISED FOR COMMENTS	2014/04/02
16	REVISED FOR COMMENTS	2014/04/02
17	REVISED FOR COMMENTS	2014/04/02
18	REVISED FOR COMMENTS	2014/04/02
19	REVISED FOR COMMENTS	2014/04/02
20	REVISED FOR COMMENTS	2014/04/02

Jablonsky, Asif and Partners ENGINEERS
 400 BAYVIEW AVE. SUITE 200
 SCARBOROUGH, ONTARIO M1B 2Y5
 TEL: 416-444-2727
 FAX: 416-444-2727
 E-MAIL: info@jablonsky.com

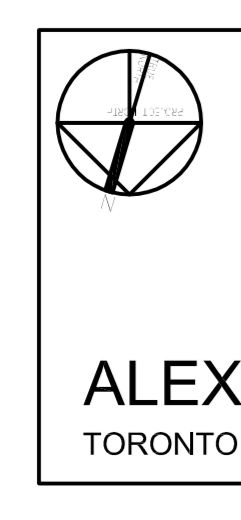

ALEXANDRA PARK - BLOCK 11
 TORONTO, ONTARIO

P2 PARKING LEVEL
 (FOUNDATION PLAN)
 S-101