

DETAIL OF RETAINING WALL OPTION A
SCALE 1:20

NOTE:
1. PROVIDE T.L.S.(TENSION LAP SIZE) FOR ALL HORIZONTAL BARS AND ADJACENT WALLS (LVS SHALL BE 35 WPA, CLASS C-40) WITH MIN. 7% TO BE ENRICHED AIR.
2. CONCRETE STRENGTH AT 28 DAYS SHALL BE 35 MPA.
3. SET ARCH AND LANDSCAPE DRAWING FOR LOCATION OF FENCE POST.
4. SEE LANDSCAPE DRAWINGS FOR FENCE DETAILS.

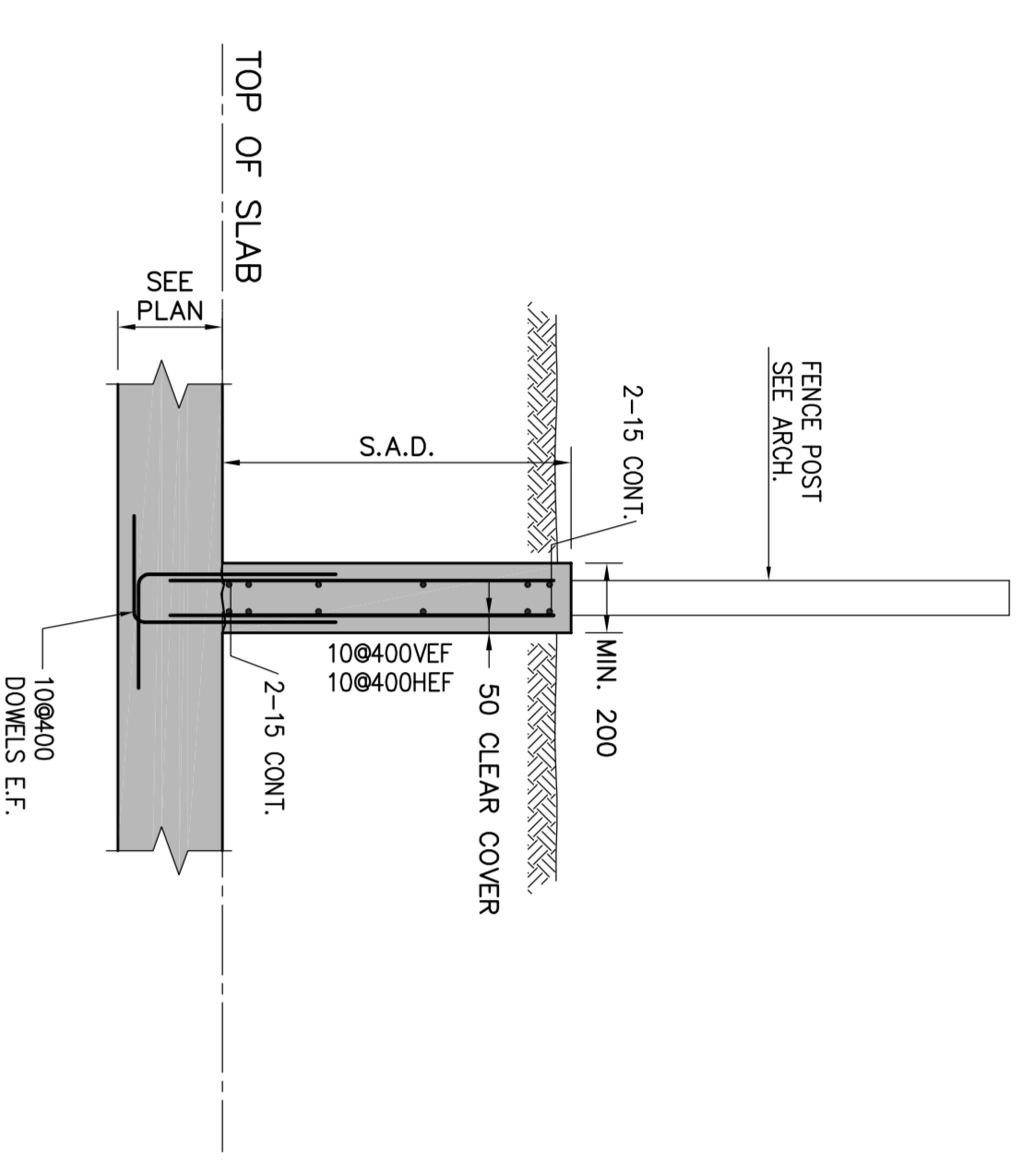

DETAIL OF PLANTER WALL
SCALE 1:20

NOTE:
1. PROVIDE T.L.S.(TENSION LAP SIZE) FOR ALL HORIZONTAL BARS AND T.L.S. AND ADJACENT WALLS. (LVS SHALL BE 35 WPA, CLASS C-40) WITH MIN. 7% TO BE ENRICHED AIR.
2. CONCRETE STRENGTH AT 28 DAYS SHALL BE 35 MPA.
3. SET ARCH AND LANDSCAPE DRAWING FOR LOCATION OF FENCE POST.

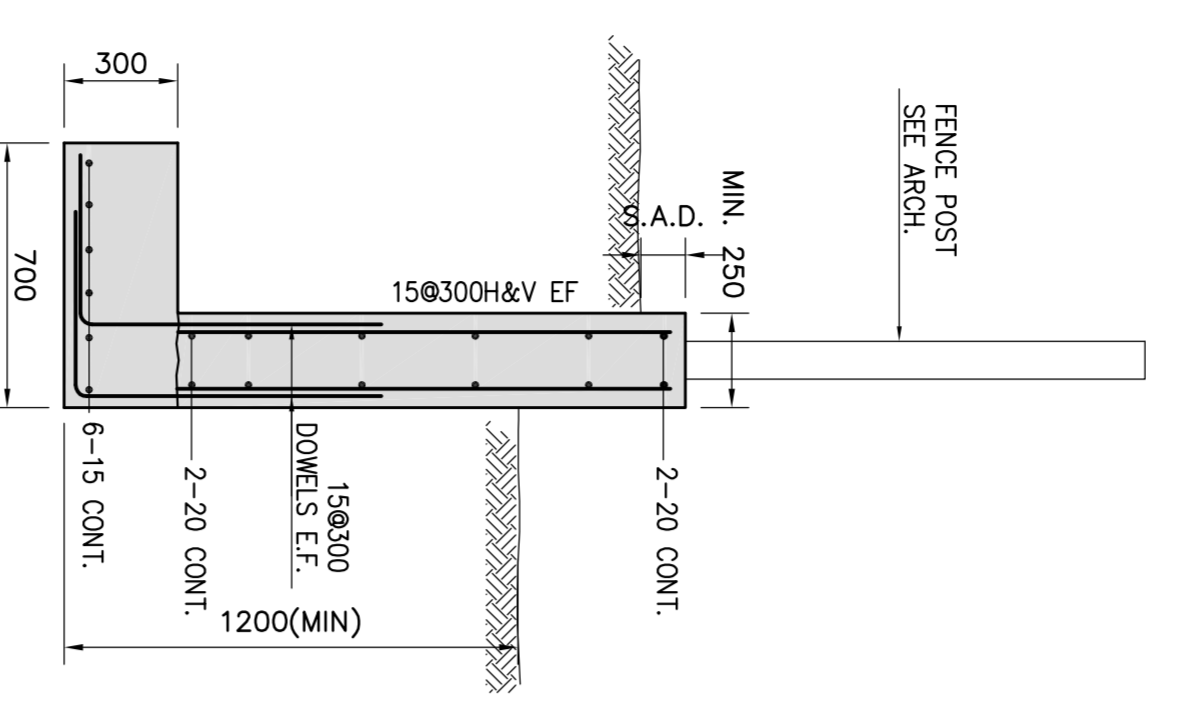

DETAIL OF RETAINING WALL OPTION B
SCALE 1:20

NOTE:
1. PROVIDE T.L.S.(TENSION LAP SIZE) FOR ALL HORIZONTAL BARS AND ADJACENT WALLS (LVS SHALL BE 35 WPA, CLASS C-40) WITH MIN. 7% TO BE ENRICHED AIR.
2. CONCRETE STRENGTH AT 28 DAYS SHALL BE 35 MPA.
3. SET ARCH AND LANDSCAPE DRAWING FOR LOCATION OF FENCE POST.
4. SEE LANDSCAPE DRAWINGS FOR FENCE DETAILS.

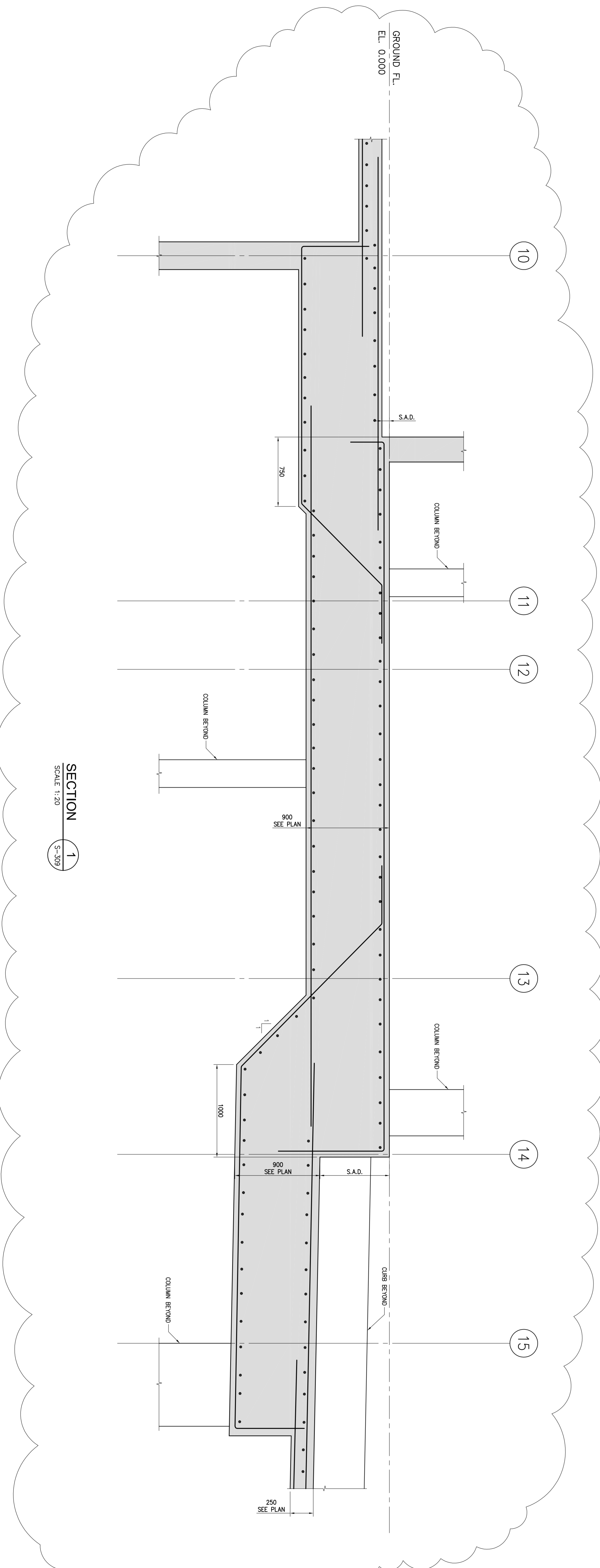

FIRST FLOOR ELEV. 80.00m

NO.	Issued / Revises	DATE
1	ISSUED FOR PERMIT	2014/03/10
2	REVISIONS	2014/03/10
3	REVISIONS	2014/03/10
4	REVISIONS	2014/03/10
5	REVISIONS	2014/03/10
6	REVISIONS	2014/03/10
7	REVISIONS	2014/03/10
8	REVISIONS	2014/03/10
9	REVISIONS	2014/03/10
10	REVISIONS	2014/03/10

Jablonsky, Asif and Partners ENGINEERS
 1300 BAYVIEW AVE. SUITE 200
 SCARBOROUGH, ONTARIO M1B 4Y7
 TEL: 416-447-2727
 FAX: 416-447-2727
 E-MAIL: info@jablonsky.com

P.F. ASIF
 1300 BAYVIEW AVE. SUITE 200
 SCARBOROUGH, ONTARIO M1B 4Y7
 TEL: 416-447-2727
 FAX: 416-447-2727
 E-MAIL: p.asif@jablonsky.com

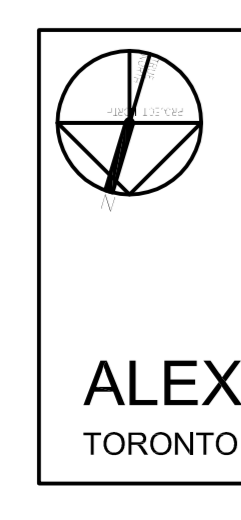

ALEXANDRA PARK - BLOCK 11
 TORONTO, ONTARIO

DATE: 11/10
 DRAWN BY: H.M.
 CHECKED BY: H.M.
 DATE: MARCH 2014