

GENERAL AREA CIRCUITING - TABLE #1

LIGHTING FIXTURE LOCATION	COL.
F2 TO F1 - EXIT SIGNS	E-1
G/F TO MPH - EXIT SIGNS	E-3
MPH - EXIT SIGNS	ER-1
STAIR 'A' (F2 TO G/F)	E-5
STAIR 'B' (F2 TO G/F)	E-7
STAIR 'J' (G/F TO 4/F)	E-9
STAIR 'J' (B/F TO 3/F)	E-11
STAIR 'G' (G/F TO 14/F)	E-13
STAIR 'F' (G/F TO 14/F)	E-15
STAIR 'K' (14/F TO MPH) 4 MPH (G/F)	E-2E-4E-6E-10E-8E-10E-12E-14E-16 E-1-2B-1-4B-6B-8B-10B-12B-14B-16B-18B-19B-20B-22B-24B-26B-28B-30
CORRIDOR (2/F 4 3/F)	E-24
CORRIDOR (4/F 4 5/F)	E-26
CORRIDOR (6/F 4 7/F)	E-28
CORRIDOR (8/F TO 11/F)	E-30
CORRIDOR (12/F TO 14/F)	E-32
CORRIDOR 1 LOCKER (2/F)	B-46
CORRIDOR (3/F)	B-48
CORRIDOR (4/F)	B-50
CORRIDOR (5/F 4 6/F)	B-52
CORRIDOR (7/F 4 8/F)	B-54
CORRIDOR (9/F TO 11/F)	B-56
CORRIDOR (12/F TO 14/F)	B-58
ELEVATOR CAB	ER-6, ER-8ER-10
EXTERIOR SITE	E-1E1-3E1-5E1-7E1-4E1-6
RECEPTACLE LOCATION	COL.
ELEC. S. CLOSET (G/F TO 9/F)	B-2
ELEC. N. CLOSET (2/F TO 9/F)	B-4
ELEC. N. CLOSET (10/F TO 14/F)	B-6
ELEC. N. CLOSET (22/F TO 32/F)	B-8
ELEV. LOBBY (F2 TO 8/F)	B-10
CORRIDOR (2/F TO 8/F)	B-12B-14B-16B-18B-20B-22B-24
CORRIDOR (2/F TO 5/F)	B-26B-28
ELEV. LOBBY (9 TO 14/F)	B-30
CORRIDOR (9/F TO 14/F)	B-32B-34B-36B-38
STAIR A (G/F) 4 1/3/5/6/F/3/F)	B-40
STAIR F (14/F/11/F/8/F/5/F/2/F)	B-42
STAIR H (14/F/11/F/8/F/5/F/2/F)	B-44
STAIR 'K' 4 MPH	R-2

- KEY NOTES - INSUITE:**
- DESIGNATED "LAUNDRY RECEPTACLE" AS DEFINED BY ESA CODE 26-1101(9.11), 26-1201(1) AND ESA BULLETIN 26-26-01 WITHIN 3M RADIUS OF LAUNDRY CLOSET RECEPTACLE SHALL BE CONNECTED TO A DEDICATED CIRCUIT. SEE DETAIL #14 ON DUG. E-35.
 - SUITE DOOR CONTACTS AND GLASS BREAK DETECTOR WILL COMPLETE WITH INTRUSION ALARM SYSTEM THAT CONTACT TO THE CONCIERGE STATION. (TYPICAL)
 - FOR FAN COIL UNITS (FCU) ELECTRICAL CONTRACTOR TO SUPPLY AND INSTALL CONDUIT AND JUNCTION BOX FOR REMOTE THERMOSTAT. MECHANICAL CONTRACTOR SHALL SUPPLY, WIRE, TERMINATE WIRING AND MOUNT THERMOSTAT.
 - INSTALL SIDE-MOUNTED RECEPTACLE ON KITCHEN ISLAND CABINET.
 - SWITCHES, RECEPTACLES, ETC., TO BE INSTALLED AS TO NOT INTERFERE WITH THE OPENING AND OPERATION OF SLIDING DOOR.
 - TERRACE LIGHTING FIXTURE AND RECEPTACLE SHALL BE CENTERED ON PANEL (350MM FROM CENTRE OF DOOR MULLION). REFER TO ARCHITECTURAL ELEVATION.

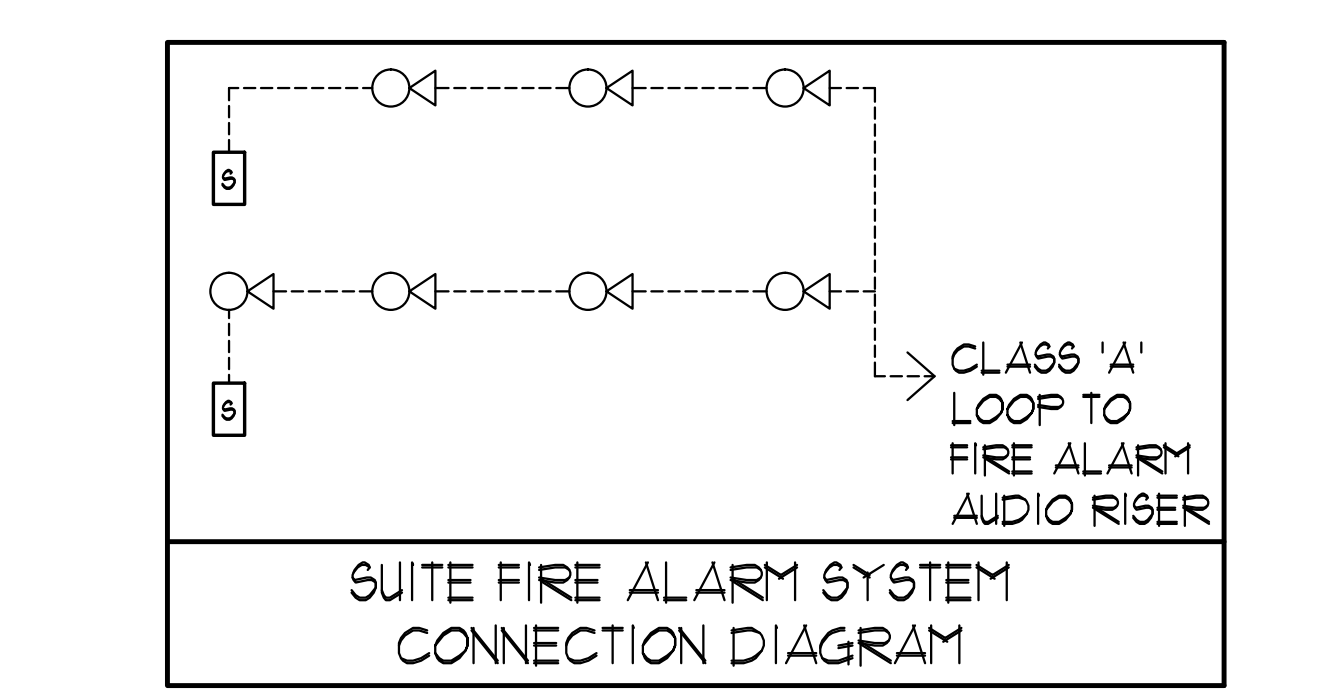

MOUNTING HEIGHT SCHEDULE (TO TOP OF BOX)

OUTLET	SUITES	PUBLIC AREA
RECEPTACLE	400 MM AFF.	400 MM AFF.
TV OUTLET	400 MM AFF.	400 MM AFF.
TELEPHONE OUTLET	400 MM AFF.	400 MM AFF.
MULTI-FORT OUTLET	400 MM AFF.	400 MM AFF.
SWITCH	1200 MM AFF.	1200 MM AFF.
SECURITY PANEL	1200 MM AFF.	
SILENCE SWITCHES	1200 MM AFF.	
THERMOSTAT	1200 MM AFF.	1200 MM AFF.
INTERCOM		1200 MM AFF.
V.C. HANDSET		1200 MM AFF.
FULL STATION		1200 MM AFF.

- GENERAL NOTES - RESIDENTIAL:**
- ELECTRICAL DRAWINGS SHALL BE READ IN CONJUNCTION WITH MECHANICAL, STRUCTURAL, ARCHITECTURAL AND LANDSCAPE DRAWINGS.
 - CONTRACTOR SHALL RUN CABLES WITHIN CEILING SLAB OR ENCLOSURES TO RETAIN 2 HOUR FIRE PROTECTION RATING FOR ALL LOADS THAT CONNECT TO EMERGENCY POWER.
 - FIRE ALARM RISERS SHALL BE RUN IN 2 HOUR FIRE RATED ELECTRICAL CLOSET. REFER TO DUG. E-32 FOR RISER DIAGRAM AND DETAILS.
 - STAIRWAY WALL MOUNTED EMERGENCY LIGHT FIXTURES SHALL BE MOUNTED @ 1' AFF. MIN.
 - FOR STORAGE ROOM VENTILATION SYSTEM, DIV. 16 TO PROVIDE CONDUIT, WIRING AND SWITCH (S) TO START/STOP FAN AND DAMPER. FAN AND 110V ACTUATOR TO BE SUPPLIED AND INSTALLED BY DIV. 15.
 - FOR UTILITY ROOM VENTILATION SYSTEM, DIV. 15 WILL PROVIDE LINE VOLTAGE THERMOSTAT (T) TO DIV. 16. DIV. 16 TO PROVIDE CONDUIT AND WIRING TO START/STOP FAN AND DAMPER VIA THERMOSTAT. FAN AND 110V ACTUATOR TO BE SUPPLIED AND INSTALLED BY DIV. 15.
- KEY NOTES - RESIDENTIAL - COMMON AREA:**
- FOR CIRCUITING, REFER TO TABLE #1.
 - PROVIDE ALARM SPEAKER SMOKE DETECTOR AND RECEPTACLE AT EVERY THIRD FLOOR STAIR WELL STARTING FROM TOP FLOOR, AS PER TO DUG. E-32 FOR FIRE ALARM RISER DIAGRAM.
 - PROVIDE TELECOMMUNICATION BACKBOARD CAB 115V, 1Ø, 15A RECEPTACLE AS PER COMMUNICATION RISER DIAGRAM ON DUG. E-31.
 - CONTRACTOR SHALL REFER TO ELECTRICAL SINGLE LINE DIAGRAM ON DUG. E-30 AND SDP RISER ON DUG. E-31 FOR SDP LOCATIONS AND DISTRIBUTION.
 - PROVIDE CONDUIT AS PER RISER DETAIL #13 ON DUG. E-35 FOR TRISORTER CONTROL SYSTEM.
 - REFER TO SUPERVISED VALVE AND FLOW SWITCH SCHEDULE ON DUG. E-33 FOR DETAILS ON TYPICAL FLOORS.

ELECTRICAL LEGEND

LIGHTING

- FLUORESCENT LIGHT FIXTURE TYPE AS INDICATED
- NIGHT LIGHT OR LIGHT CONNECTED TO EMERGENCY POWER
- CEILING POINTED WALL MOUNTED LIGHT FIXTURE
- POLE MOUNTED LIGHT FIXTURE
- POLE MOUNTED LIGHT FIXTURE, INSCRIBED LETTER DENOTES TYPE
- CAPPED CEILING LIGHT OUTLET
- TRACK LIGHT
- STREP LIGHT
- UNDER CABINET FLUORESCENT LIGHT FIXTURE
- CEILING POINTED WALL MOUNTED EXIT SIGN
- SINGLE-LEGAL EMERGENCY LAMP REPOSE HEAD
- EMERGENCY BATTERY PACK
- OCCUPANCY SENSOR POWER PACKS
- SINGLE-LEGAL POLE MOUNTED LIGHT FIXTURE THROUGH TUGGLE SWITCH RESPECTIVELY, 1/4" 1/8" 1/2" 3/4" 1" 1 1/2" 2" 2 1/2" 3" 3 1/2" 4" 4 1/2" 5" 5 1/2" 6" 6 1/2" 7" 7 1/2" 8" 8 1/2" 9" 9 1/2" 10" 10 1/2" 11" 11 1/2" 12" 12 1/2" 13" 13 1/2" 14" 14 1/2" 15" 15 1/2" 16" 16 1/2" 17" 17 1/2" 18" 18 1/2" 19" 19 1/2" 20" 20 1/2" 21" 21 1/2" 22" 22 1/2" 23" 23 1/2" 24" 24 1/2" 25" 25 1/2" 26" 26 1/2" 27" 27 1/2" 28" 28 1/2" 29" 29 1/2" 30" 30 1/2" 31" 31 1/2" 32" 32 1/2" 33" 33 1/2" 34" 34 1/2" 35" 35 1/2" 36" 36 1/2" 37" 37 1/2" 38" 38 1/2" 39" 39 1/2" 40" 40 1/2" 41" 41 1/2" 42" 42 1/2" 43" 43 1/2" 44" 44 1/2" 45" 45 1/2" 46" 46 1/2" 47" 47 1/2" 48" 48 1/2" 49" 49 1/2" 50" 50 1/2" 51" 51 1/2" 52" 52 1/2" 53" 53 1/2" 54" 54 1/2" 55" 55 1/2" 56" 56 1/2" 57" 57 1/2" 58" 58 1/2" 59" 59 1/2" 60" 60 1/2" 61" 61 1/2" 62" 62 1/2" 63" 63 1/2" 64" 64 1/2" 65" 65 1/2" 66" 66 1/2" 67" 67 1/2" 68" 68 1/2" 69" 69 1/2" 70" 70 1/2" 71" 71 1/2" 72" 72 1/2" 73" 73 1/2" 74" 74 1/2" 75" 75 1/2" 76" 76 1/2" 77" 77 1/2" 78" 78 1/2" 79" 79 1/2" 80" 80 1/2" 81" 81 1/2" 82" 82 1/2" 83" 83 1/2" 84" 84 1/2" 85" 85 1/2" 86" 86 1/2" 87" 87 1/2" 88" 88 1/2" 89" 89 1/2" 90" 90 1/2" 91" 91 1/2" 92" 92 1/2" 93" 93 1/2" 94" 94 1/2" 95" 95 1/2" 96" 96 1/2" 97" 97 1/2" 98" 98 1/2" 99" 99 1/2" 100" 100 1/2" 101" 101 1/2" 102" 102 1/2" 103" 103 1/2" 104" 104 1/2" 105" 105 1/2" 106" 106 1/2" 107" 107 1/2" 108" 108 1/2" 109" 109 1/2" 110" 110 1/2" 111" 111 1/2" 112" 112 1/2" 113" 113 1/2" 114" 114 1/2" 115" 115 1/2" 116" 116 1/2" 117" 117 1/2" 118" 118 1/2" 119" 119 1/2" 120" 120 1/2" 121" 121 1/2" 122" 122 1/2" 123" 123 1/2" 124" 124 1/2" 125" 125 1/2" 126" 126 1/2" 127" 127 1/2" 128" 128 1/2" 129" 129 1/2" 130" 130 1/2" 131" 131 1/2" 132" 132 1/2" 133" 133 1/2" 134" 134 1/2" 135" 135 1/2" 136" 136 1/2" 137" 137 1/2" 138" 138 1/2" 139" 139 1/2" 140" 140 1/2" 141" 141 1/2" 142" 142 1/2" 143" 143 1/2" 144" 144 1/2" 145" 145 1/2" 146" 146 1/2" 147" 147 1/2" 148" 148 1/2" 149" 149 1/2" 150" 150 1/2" 151" 151 1/2" 152" 152 1/2" 153" 153 1/2" 154" 154 1/2" 155" 155 1/2" 156" 156 1/2" 157" 157 1/2" 158" 158 1/2" 159" 159 1/2" 160" 160 1/2" 161" 161 1/2" 162" 162 1/2" 163" 163 1/2" 164" 164 1/2" 165" 165 1/2" 166" 166 1/2" 167" 167 1/2" 168" 168 1/2" 169" 169 1/2" 170" 170 1/2" 171" 171 1/2" 172" 172 1/2" 173" 173 1/2" 174" 174 1/2" 175" 175 1/2" 176" 176 1/2" 177" 177 1/2" 178" 178 1/2" 179" 179 1/2" 180" 180 1/2" 181" 181 1/2" 182" 182 1/2" 183" 183 1/2" 184" 184 1/2" 185" 185 1/2" 186" 186 1/2" 187" 187 1/2" 188" 188 1/2" 189" 189 1/2" 190" 190 1/2" 191" 191 1/2" 192" 192 1/2" 193" 193 1/2" 194" 194 1/2" 195" 195 1/2" 196" 196 1/2" 197" 197 1/2" 198" 198 1/2" 199" 199 1/2" 200" 200 1/2" 201" 201 1/2" 202" 202 1/2" 203" 203 1/2" 204" 204 1/2" 205" 205 1/2" 206" 206 1/2" 207" 207 1/2" 208" 208 1/2" 209" 209 1/2" 210" 210 1/2" 211" 211 1/2" 212" 212 1/2" 213" 213 1/2" 214" 214 1/2" 215" 215 1/2" 216" 216 1/2" 217" 217 1/2" 218" 218 1/2" 219" 219 1/2" 220" 220 1/2" 221" 221 1/2" 222" 222 1/2" 223" 223 1/2" 224" 224 1/2" 225" 225 1/2" 226" 226 1/2" 227" 227 1/2" 228" 228 1/2" 229" 229 1/2" 230" 230 1/2" 231" 231 1/2" 232" 232 1/2" 233" 233 1/2" 234" 234 1/2" 235" 235 1/2" 236" 236 1/2" 237" 237 1/2" 238" 238 1/2" 239" 239 1/2" 240" 240 1/2" 241" 241 1/2" 242" 242 1/2" 243" 243 1/2" 244" 244 1/2" 245" 245 1/2" 246" 246 1/2" 247" 247 1/2" 248" 248 1/2" 249" 249 1/2" 250" 250 1/2" 251" 251 1/2" 252" 252 1/2" 253" 253 1/2" 254" 254 1/2" 255" 255 1/2" 256" 256 1/2" 257" 257 1/2" 258" 258 1/2" 259" 259 1/2" 260" 260 1/2" 261" 261 1/2" 262" 262 1/2" 263" 263 1/2" 264" 264 1/2" 265" 265 1/2" 266" 266 1/2" 267" 267 1/2" 268" 268 1/2" 269" 269 1/2" 270" 270 1/2" 271" 271 1/2" 272" 272 1/2" 273" 273 1/2" 274" 274 1/2" 275" 275 1/2" 276" 276 1/2" 277" 277 1/2" 278" 278 1/2" 279" 279 1/2" 280" 280 1/2" 281" 281 1/2" 282" 282 1/2" 283" 283 1/2" 284" 284 1/2" 285" 285 1/2" 286" 286 1/2" 287" 287 1/2" 288" 288 1/2" 289" 289 1/2" 290" 290 1/2" 291" 291 1/2" 292" 292 1/2" 293" 293 1/2" 294" 294 1/2" 295" 295 1/2" 296" 296 1/2" 297" 297 1/2" 298" 298 1/2" 299" 299 1/2" 300" 300 1/2" 301" 301 1/2" 302" 302 1/2" 303" 303 1/2" 304" 304 1/2" 305" 305 1/2" 306" 306 1/2" 307" 307 1/2" 308" 308 1/2" 309" 309 1/2" 310" 310 1/2" 311" 311 1/2" 312" 312 1/2" 313" 313 1/2" 314" 314 1/2" 315" 315 1/2" 316" 316 1/2" 317" 317 1/2" 318" 318 1/2" 319" 319 1/2" 320" 320 1/2" 321" 321 1/2" 322" 322 1/2" 323" 323 1/2" 324" 324 1/2" 325" 325 1/2" 326" 326 1/2" 327" 327 1/2" 328" 328 1/2" 329" 329 1/2" 330" 330 1/2" 331" 331 1/2" 332" 332 1/2" 333" 333 1/2" 334" 334 1/2" 335" 335 1/2" 336" 336 1/2" 337" 337 1/2" 338" 338 1/2" 339" 339 1/2" 340" 340 1/2" 341" 341 1/2" 342" 342 1/2" 343" 343 1/2" 344" 344 1/2" 345" 345 1/2" 346" 346 1/2" 347" 347 1/2" 348" 348 1/2" 349" 349 1/2" 350" 350 1/2" 351" 351 1/2" 352" 352 1/2" 353" 353 1/2" 354" 354 1/2" 355" 355 1/2" 356" 356 1/2" 357" 357 1/2" 358" 358 1/2" 359" 359 1/2" 360" 360 1/2" 361" 361 1/2" 362" 362 1/2" 363" 363 1/2" 364" 364 1/2" 365" 365 1/2" 366" 366 1/2" 367" 367 1/2" 368" 368 1/2" 369" 369 1/2" 370" 370 1/2" 371" 371 1/2" 372" 372 1/2" 373" 373 1/2" 374" 374 1/2" 375" 375 1/2" 376" 376 1/2" 377" 377 1/2" 378" 378 1/2" 379" 379 1/2" 380" 380 1/2" 381" 381 1/2" 382" 382 1/2" 383" 383 1/2" 384" 384 1/2" 385" 385 1/2" 386" 386 1/2" 387" 387 1/2" 388" 388 1/2" 389" 389 1/2" 390" 390 1/2" 391" 391 1/2" 392" 392 1/2" 393" 393 1/2" 394" 394 1/2" 395" 395 1/2" 396" 396 1/2" 397" 397 1/2" 398" 398 1/2" 399" 399 1/2" 400" 400 1/2" 401" 401 1/2" 402" 402 1/2" 403" 403 1/2" 404" 404 1/2" 405" 405 1/2" 406" 406 1/2" 407" 407 1/2" 408" 408 1/2" 409" 409 1/2" 410" 410 1/2" 411" 411 1/2" 412" 412 1/2" 413" 413 1/2" 414" 414 1/2" 415" 415 1/2" 416" 416 1/2" 417" 417 1/2" 418" 418 1/2" 419" 419 1/2" 420" 420 1/2" 421" 421 1/2" 422" 422 1/2" 423" 423 1/2" 424" 424 1/2" 425" 425 1/2" 426" 426 1/2" 427" 427 1/2" 428" 428 1/2" 429" 429 1/2" 430" 430 1/2" 431" 431 1/2" 432" 432 1/2" 433" 433 1/2" 434" 434 1/2" 435" 435 1/2" 436" 436 1/2" 437" 437 1/2" 438" 438 1/2" 439" 439 1/2" 440" 440 1/2" 441" 441 1/2" 442" 442 1/2" 443" 443 1/2" 444" 444 1/2" 445" 445 1/2" 446" 446 1/2" 447" 447 1/2" 448" 448 1/2" 449" 449 1/2" 450" 450 1/2" 451" 451 1/2" 452" 452 1/2" 453" 453 1/2" 454" 454 1/2" 455" 455 1/2" 456" 456 1/2" 457" 457 1/2" 458" 458 1/2" 459" 459 1/2" 460" 460 1/2" 461" 461 1/2" 462" 462 1/2" 463" 463 1/2" 464" 464 1/2" 465" 465 1/2" 466" 466 1/2" 467" 467 1/2" 468" 468 1/2" 469" 469 1/2" 470" 470 1/2" 471" 471 1/2" 472" 472 1/2" 473" 473 1/2" 474" 474 1/2" 475" 475 1/2" 476" 476 1/2" 477" 477 1/2" 478" 478 1/2" 479" 479 1/2" 480" 480 1/2" 481" 481 1/2" 482" 482 1/2" 483" 483 1/2" 484" 484 1/2" 485" 485 1/2" 486" 486 1/2" 487" 487 1/2" 488" 488 1/2" 489" 489 1/2" 490" 490 1/2" 491" 491 1/2" 492" 492 1/2" 493" 493 1/2" 494" 494 1/2" 495" 495 1/2" 496" 496 1/2" 497" 497 1/2" 498" 498 1/2" 499" 499 1/2" 500" 500 1/2" 501" 501 1/2" 502" 502 1/2" 503" 503 1/2" 504" 504 1/2" 505" 505 1/2" 506" 506 1/2" 507" 507 1/2" 508" 508 1/2" 509" 509 1/2" 510" 510 1/2" 511" 511 1/2" 512" 512 1/2" 513" 513 1/2" 514" 514 1/2" 515" 515 1/2" 516" 516 1/2" 517" 517 1/2" 518" 518 1/2" 519" 519 1/2" 520" 520 1/2" 521" 521 1/2" 522" 522 1/2" 523" 523 1/2" 524" 524 1/2" 525" 525 1/2" 526" 526 1/2" 527" 527 1/2" 528" 528 1/2" 529" 529 1/2" 530" 530 1/2" 531" 531 1/2" 532" 532 1/2" 533" 533 1/2" 534" 534 1/2" 535" 535 1/2" 536" 536 1/2" 537" 537 1/2" 538" 538 1/2" 539" 539 1/2" 540" 540 1/2" 541" 541 1/2" 542" 542 1/2" 543" 543 1/2" 544" 544 1/2" 545" 545 1/2" 546" 546 1/2" 547" 547 1/2" 548" 548 1/2" 549" 549 1/2" 550" 550 1/2" 551" 551 1/2" 552" 552 1/2" 553" 553 1/2" 554" 554 1/2" 555" 555 1/2" 556" 556 1/2" 557" 557 1/2" 558" 558 1/2" 559" 559 1/2" 560" 560 1/2" 561" 561 1/2" 562" 562 1/2" 563" 563 1/2" 564" 564 1/2" 565" 565 1/2" 566" 566 1/2" 567" 567 1/2" 568" 568 1/2" 569" 569 1/2" 570" 570 1/2" 571" 571 1/2" 572" 572 1/2" 573" 573 1/2" 574" 574 1/2" 575" 575 1/2" 576" 576 1/2" 577" 577 1/2" 578" 578 1/2" 579" 579 1/2" 580" 580 1/2" 581" 581 1/2" 582" 582 1/2" 583" 583 1/2" 584" 584 1/2" 585" 585 1/2" 586" 586 1/2" 587" 587 1/2" 588" 588 1/2" 589" 589 1/2" 590" 590 1/2" 591" 591 1/2" 592" 592 1/2" 593" 593 1/2" 594" 594 1/2" 595" 595 1/2" 596" 596 1/2" 597" 597 1/2" 598" 598 1/2" 599" 599 1/2" 600" 600 1/2" 601" 601 1/2" 602" 602 1/2" 603" 603 1/2" 604" 604 1/2" 605" 605 1/2" 606" 606 1/2" 607" 607 1/2" 608" 608 1/2" 609" 609 1/2" 610" 610 1/2" 611" 611 1/2" 612" 612 1/2" 613" 613 1/2" 614" 614 1/2" 615" 615 1/2" 616" 616 1/2" 617" 617 1/2" 618" 618 1/2" 619" 619 1/2" 620" 620 1/2" 621" 621 1/2" 622" 622 1/2" 623" 623 1/2" 624" 624 1/2" 625" 625 1/2" 626" 626 1/2" 627" 627 1/2" 628" 628 1/2" 629" 629 1/2" 630" 630 1/2" 631" 631 1/2" 632"