

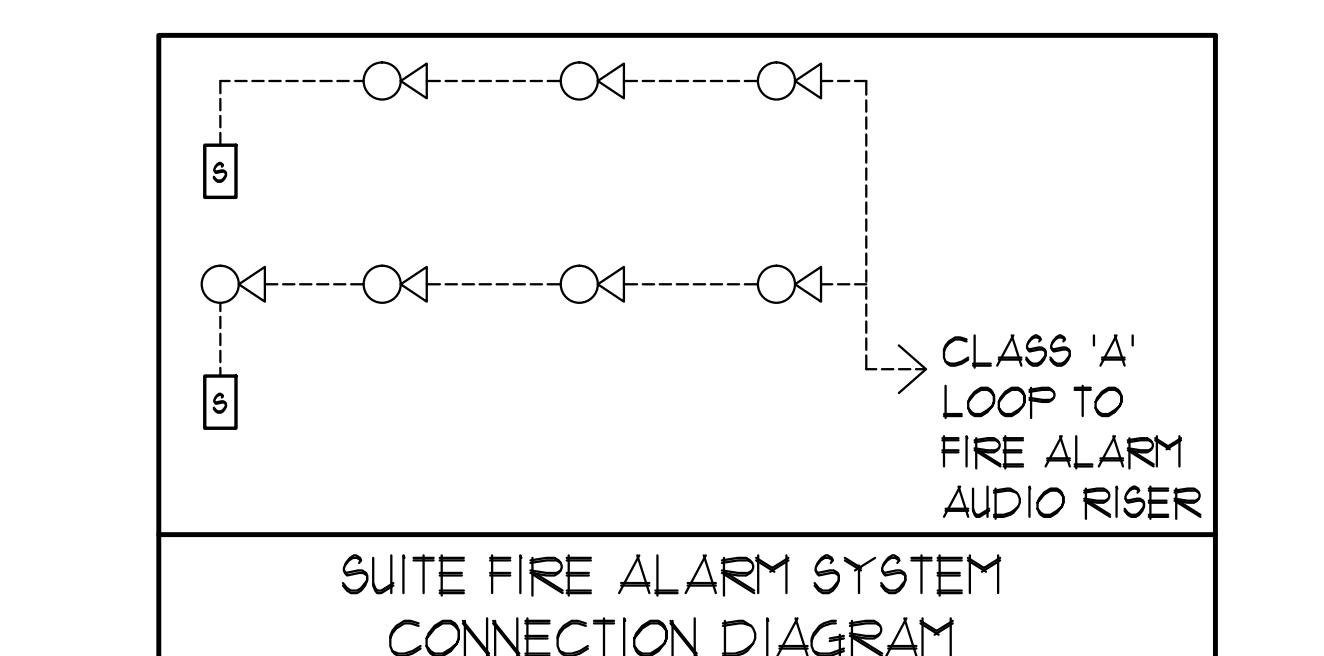

GENERAL AREA CIRCUITING - TABLE #1

LIGHTING FIXTURE LOCATION	CCT.*
F2 TO F1 - EXIT SIGNS	E-1
G/F TO MPH - EXIT SIGNS	E-3
MPH - EXIT SIGNS	ER-1
STAIR "A" (F2 TO G/F)	E-5
STAIR "B" (F2 TO G/F)	E-7
STAIR "J" (G/F TO 4/F)	E-9
STAIR "J" (B/F TO 3/F)	E-11
STAIR "G" (G/F TO 14/F)	E-13
STAIR "F" (G/F TO 14/F)	E-15
STAIR "K" (14/F TO MPH) 4 MPH (G/F)	ER-3ER-5R-11R-19
(G/F)	E-2-E-4-E-6-E-10-E-8-E-10-E-12-E-14-E-16
(G/F)	B1-2B1-4B1-6B1-8B1-10B1-12B1-14B1-16B1-18B1-20B1-22B1-24B1-26B1-28B1-30
CORRIDOR (2/F 4 3/F)	E-24
CORRIDOR (4/F 4 5/F)	E-26
CORRIDOR (6/F 4 11/F)	E-28
CORRIDOR (8/F 4 11/F)	E-30
CORRIDOR (12/F TO 14/F)	E-32
CORRIDOR 4 LOCKER (2/F)	B-46
CORRIDOR (3/F)	B-48
CORRIDOR (4/F)	B-50
CORRIDOR (5/F 4 6/F)	B-52
CORRIDOR (7/F 4 8/F)	B-54
CORRIDOR (9/F TO 11/F)	B-56
CORRIDOR (12/F TO 14/F)	B-58
ELEVATOR CAB	ER-6, ER-8ER-10
EXTERIOR SITE	E1-E1-3E1-5E1-2E1-4E1-6
RECEPTACLE LOCATION	CCT.*
ELEC. S. CLOSET (G/F TO 9/F)	B-2
ELEC. N. CLOSET (2/F TO 9/F)	B-4
ELEC. N. CLOSET (10/F TO 14/F)	B-6
ELEC. N. CLOSET (22/F TO 32/F)	B-8
ELEV. LOBBY (F2 TO 8/F)	B-10
CORRIDOR (2/F TO 8/F)	B-12B-14B-16B-18B-20B-22B-24
CORRIDOR (2/F TO 5/F)	B-26B-28
ELEV. LOBBY (9 TO 14/F)	B-30
CORRIDOR (9/F TO 14/F)	B-32B-34B-36B-38
STAIR A (G/F) 4 J(9/F,6/F,3/F)	B-40
STAIR F (14/F,11/F,8/F,5/F,2/F)	B-42
STAIR H (14/F,11/F,8/F,5/F,2/F)	B-44
STAIR "K" 4 MPH	R-2

- KEY NOTES - INSUITE:**
- DESIGNATED "LAUNDRY RECEPTACLE" AS DEFINED BY E.S.A. CODE 26-1101(8)(1), 26-1101(1) AND E.S.A. BULLETIN 26-26-01 WITHIN 3m RADIUS OF LAUNDRY CLOSET. RECEPTACLE SHALL BE CONNECTED TO A DEDICATED CIRCUIT. SEE DETAIL #4 ON DUG. E-35.
 - SUITE DOOR CONTACTS AND GLASS BREAK DETECTOR WILL COMPLETE WITH INTRUSION ALARM SYSTEM THAT CONTACT TO THE CONCERGE STATION. (TYPICAL)
 - FOR FAN COIL UNITS (FCU) ELECTRICAL CONTRACTOR TO SUPPLY AND INSTALL CONDUIT AND JUNCTION BOX FOR REMOTE THERMOSTAT. MECHANICAL CONTRACTOR SHALL SUPPLY, WIRE, TERMINATE WIRING AND MOUNT THERMOSTAT.
 - INSTALL SIDE-MOUNTED RECEPTACLE ON KITCHEN ISLAND CABINET.
 - SWITCHES, RECEPTACLES, ETC. TO BE INSTALLED AS TO NOT INTERFERE WITH THE OPENING AND OPERATION OF SLIDING DOOR.
 - TERRACE LIGHTING FIXTURE AND RECEPTACLE SHALL BE CENTERED ON PANEL (350MM FROM CENTRE OF DOOR MULLION). REFER TO ARCHITECTURAL ELEVATION.



MOUNTING HEIGHT SCHEDULE (TO TOP OF BOX)

OUTLET	SUITES	PUBLIC AREA
RECEPTACLE	400 MM AFF.	400 MM AFF.
TV OUTLET	400 MM AFF.	400 MM AFF.
TELEPHONE OUTLET	400 MM AFF.	400 MM AFF.
MULTI-PORT OUTLET	400 MM AFF.	400 MM AFF.
SWITCH	1200 MM AFF.	1200 MM AFF.
SECURITY PANEL	1200 MM AFF.	
SILENCE SWITCHES	1200 MM AFF.	
THERMOSTAT	1200 MM AFF.	1200 MM AFF.
INTERCOM		1200 MM AFF.
V.C. HANDSET		1200 MM AFF.
FULL STATION		1200 MM AFF.

- GENERAL NOTES - RESIDENTIAL:**
- ELECTRICAL DRAWINGS SHALL BE READ IN CONJUNCTION WITH MECHANICAL, STRUCTURAL, ARCHITECTURAL AND LANDSCAPE DRAWINGS.
 - CONTRACTOR SHALL RUN CABLES WITHIN CEILING SLAB OR ENCLOSURES TO RETAIN 2 HOUR FIRE PROTECTION RATING FOR ALL LOADS THAT CONNECT TO EMERGENCY POWER.
 - FIRE ALARM RISERS SHALL BE RUN IN 2 HOUR FIRE RATED ELECTRICAL CLOSET. REFER TO DUG. E-32 FOR RISER DIAGRAM AND DETAILS.
 - STAIRWAY WALL MOUNTED EMERGENCY LIGHT FIXTURES SHALL BE MOUNTED @ 1' AFF. MIN.
 - FOR STORAGE ROOM VENTILATION SYSTEM, DIV. 16 TO PROVIDE CONDUIT, WIRING AND SWITCH (S) TO START/STOP FAN AND DAMPER. FAN AND 110V ACTUATOR TO BE SUPPLIED AND INSTALLED BY DIV. 15.
 - FOR UTILITY ROOM VENTILATION SYSTEM, DIV. 15 WILL PROVIDE LINE VOLTAGE THERMOSTAT (T) TO DIV. 16. DIV. 16 TO PROVIDE CONDUIT AND WIRING TO START/STOP FAN AND DAMPER VIA THERMOSTAT. FAN AND 110V ACTUATOR TO BE SUPPLIED AND INSTALLED BY DIV. 15.
 - FOR UNIT HEATER, DIV. 15 TO PROVIDE LINE VOLTAGE THERMOSTAT (T), DIV. 16 TO PROVIDE CONDUIT AND WIRING TO START/STOP UNIT HEATER.
 - REFER TO SPRINKLER DRAWINGS FOR FIRE PROTECTION DEVICE TO BE CONNECTED TO THE FIRE ALARM SYSTEM. THE DEVICE AND EQUIPMENT SHALL FORM AN INTEGRAL PART OF THE ELECTRICAL CONTRACT.
 - DIV. 16 SHALL SUPPLY AND INSTALL CONDUITS, WIRES AND INTERLOCK FANS TO MOTORIZED DAMPERS AND TO THE THERMOSTAT.
 - DIV. 16 SHALL SUPPLY AND INSTALL CONDUITS, WIRES AND INTERLOCK FANS TO MOTORIZED DAMPERS AND TO THE THERMOSTAT.
 - REFER TO SUITE PANEL SCHEDULES FOR INSUITE CIRCUIT ARRANGEMENT.
 - ALL DUELLING UNIT RECEPTACLES EXCEPT IN KITCHEN SHALL BE TAMPER PROOF.
 - PROVIDE GROUND FAULT PROTECTION FOR SUITE KITCHEN, AMENITY KITCHEN AND WASHROOM RECEPTACLES WITHIN 1500mm OF SINK.
 - PROVIDE TELECOMMUNICATION BOX C/W BUILT-IN RECEPTACLE FOR TELECOMMUNICATION. TELECOMMUNICATION BOX SHALL BE COMPLIANT WITH THE TELECOM SERVICE PROVIDER SPECIFICATION. REFER TO DETAIL #9 ON DUG. E-35 FOR TELECOM JUNCTION BOX INSTALLATION.
 - DRYER SENSOR TO START DRYER VENTILATION FAN AUTOMATICALLY WHEN DRYER IS RUNNING.
 - ALL SMOKE ALARMS WITHIN THE SUITE SHALL BE HARDWIRED TOGETHER AND TO A 15A, 1P CIRCUIT BREAKER AHEAD OF OTHER LOADS.
 - ALL OUTDOOR RECEPTACLES SHALL BE WEATHERPROOF (LEGRANDE CAT* 2322TRUR-GRY FOR NON-GFCI AND CAT* 1B9STRUR-GRY FOR GFCI) AND SHALL BE EQUIPPED WITH A WHILE IN USE CAST ALUMINUM COVERPLATE (LEGRANDE CAT* WUCAST1) COVERPLATE.

- KEY NOTES - RESIDENTIAL - COMMON AREA:**
- FOR CIRCUITING, REFER TO TABLE #1.
 - PROVIDE ALARM SPEAKER, SMOKE DETECTOR AND RECEPTACLE AT EVERY THIRD FLOOR STAIR WELL STARTING FROM TOP FLOOR. AS PER TO DUG. E-32 FOR FIRE ALARM RISER DIAGRAM.
 - PROVIDE TELECOMMUNICATION BACKBOARD C/W 15V, 1P, 15A RECEPTACLE AS PER COMMUNICATION RISER DIAGRAM ON DUG. E-31.
 - CONTRACTOR SHALL REFER TO ELECTRICAL SINGLE LINE DIAGRAM ON DUG. E-30 AND SDP RISER ON DUG. E-31 FOR SDP LOCATIONS AND DISTRIBUTION.
 - PROVIDE CONDUIT AS PER RISER DETAIL #9 ON DUG. E-35 FOR TRIBORTER CONTROL SYSTEM.
 - REFER TO SUPERVISED VALVE AND FLOW SWITCH SCHEDULE ON DUG. E-33 FOR DETAILS ON TYPICAL FLOORS.

ELECTRICAL LEGEND

LIGHTING

- FLUORESCENT LIGHT FIXTURE TYPE AS INDICATED
- NIGHT LIGHT OR LIGHT CONNECTED TO EMERGENCY POWER
- CEILING POINTED WALL MOUNTED LIGHT FIXTURE, INSCRIBED LETTER DENOTES TYPE
- POLE MOUNTED LIGHT FIXTURE, INSCRIBED LETTER DENOTES TYPE
- CAPPED CEILING LIGHT OUTLET
- TRACK LIGHT
- STRIP LIGHT
- UNDER CABINET FLUORESCENT LIGHT FIXTURE
- CEILING POINTED WALL MOUNTED EXIT SIGN
- ANGLEQUAD EMERGENCY LAMP REPEATE HEAD
- EMERGENCY BATTERY PACK
- OCCUPANCY SENSOR POWER PACKS
- SINGLE/THREE POLE SINGLE/THREE THROUGH TOGGLE SWITCH RESPECTIVELY, (3/1) "O" DENOTES 3-WAY-4-WAY/PLUG LIGHT, OTHER SWITCHES LIGHT RESPECTIVELY
- MASTER LIGHTING SHUT-OFF SWITCH
- SENSOR WALL SWITCH FIR SELF POWERED
- OCCUPANCY SENSOR CEILING MOUNTED

POWER

- REGULAR DUPLEX RECEPTACLE
- DUPLEX RECEPTACLE GROUND FAULT INTERRUPT
- 3-WAY/4-WAY DUPLEX RECEPTACLE
- SINGLE RECEPTACLE TYPE AND CONFIGURATION AS SPECIFIED FOR DRIVER
- CONNECTION FOR OVERCLOCKTOP
- ABOVE COUNTER DEVICE
- CEILING MOUNTED DEVICES
- FLOOR MOUNTED DEVICES
- DISCONNECT SWITCH NON-FUSED
- DISCONNECT SWITCH FUSED
- COMBINATION STARTER
- FRACTIONAL MOTOR/FAN DIRECT CONNECTION
- DIRECT CONNECTION SINGLE PHASE
- DIRECT CONNECTION THREE PHASE
- THERMOSTAT
- DRYER SENSOR
- HEAT TRACE
- ELECTRICAL HEATER
- ELECTRICAL PANEL / SECURITY PANEL

TELECOMMUNICATION

- TV/CABLE OUTLET
- TELEPHONE OUTLET
- TELEPHONE/CABLE (MULTI-PORT OUTLET)
- DATA OUTLET
- DATA/PHONE OUTLET
- N SUITE TELECOM BOX C/W RECEPTACLE
- WIFI LOCATION
- VIDEO INTERCOM
- RADIO RECEIVER

SECURITY

- INTERCOM / INTERPHONE
- INTERCOM WITH CAMERA
- PANIC BUTTON / PANIC INTERCOM STATION
- CARD READER
- AUTOMATIC RELEASE CARD ACCESS/RADIO RECEIVER
- ELECTRIC STRIKE
- MAGLOCK
- DOOR CONTACT / WINDOW CONTACT
- GLASS BREAK DETECTOR
- AUTOMATIC DOOR OPERATOR
- MOTION DETECTOR
- PUSH BUTTON
- SECURITY CAMERA

LIFE SAFETY

- FIRE ALARM SMOKE DETECTOR
- SPOKE ALARM
- FIRE ALARM DUCT TYPE SMOKE DETECTOR
- FIRE ALARM HEAT DETECTOR
- FIRE THERM 60 TO DEGRADE HEAT DETECTOR
- POSSIBLE PROOF HEAT DETECTOR
- CO ALARM
- COMBINATION SPOKE 4 CO ALARM
- CO SENSOR / NO SENSOR
- FIRE ALARM MANUAL CALL MTD.
- FIREFIGHTER'S HANDSET
- FIRE ALARM SPEAKER/SPOKE WALL MTD.
- FIRE ALARM SPEAKER WALL MTD.
- FIRE ALARM SPEAKER/SPOKE CEILING MTD.
- FIRE ALARM SPEAKER CEILING MTD.
- FIRE ALARM ANNUNCIATOR PANEL
- FIRE ALARM CONTROL PANEL

REVISIONS

NO.	DATE	DESCRIPTION

NOVA

115 West Beaver Creek Road, Unit 31
Richmond Hill, Ontario L4B 3M1
Tel: 905 882-5445
Fax: 905 882-5441
Email: cad@novatrendeng.com

11/F FLOOR PLAN ELECTRICAL LAYOUT

PROJECT TITLE: ALEXANDRA PARK
38 CAMERON STREET, BLOCK II TORONTO ONTARIO

DATE: FEB 13 2014
PROJECT NUMBER: 1313
DRAWING NUMBER: E-25