

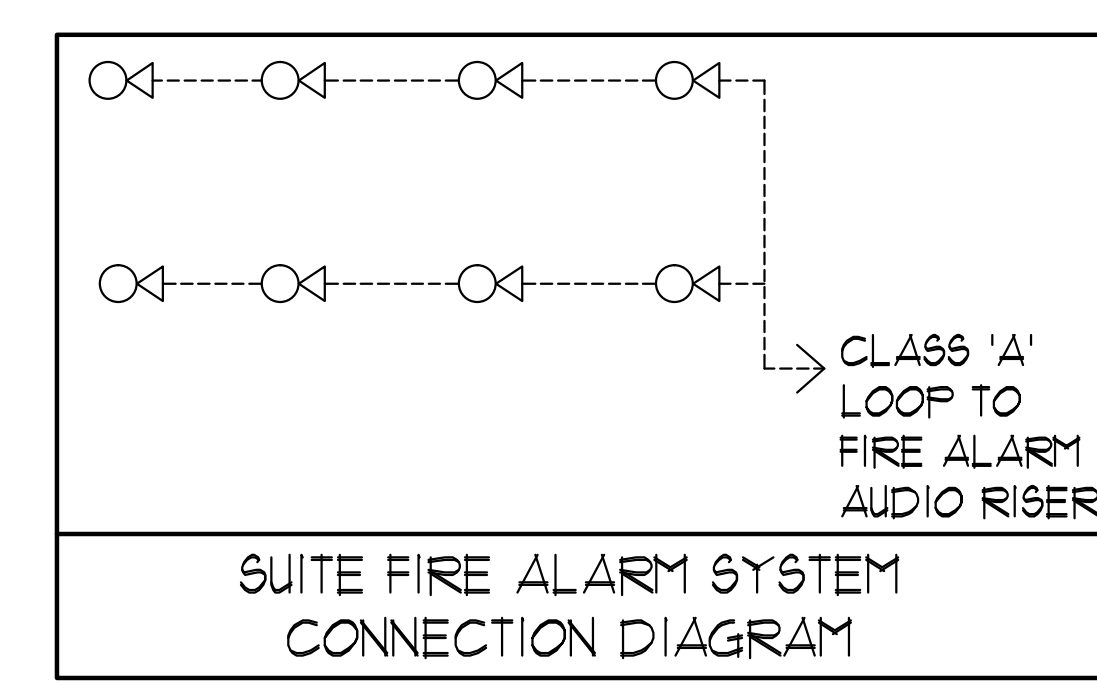

GENERAL AREA CIRCUITING - TABLE #1

RECEPTACLE LOCATION	CCT.#
LIGHT LIGHT OR P2 TO P1 - EXIT SIGNS	E-1
G/F TO MPH - EXIT SIGNS	E-3
MPH - EXIT SIGNS	ER-1
STAIR 'A' (P2 TO G/F)	E-1
STAIR 'B' (P2 TO G/F)	E-1
STAIR 'J' (G/F TO 4/F)	E-3
STAIR 'U' (G/F TO 3/F)	E-11
STAIR 'G' (G/F TO 14/F)	E-13
STAIR 'F' (G/F TO 14/F)	E-15
STAIR 'K' (14/F TO MPH) 4 MPH (G/F)	ER-3ER-5R-11R-15 E-2E-4E-6E-16E-8E-10E-12E-14E-16
CORRIDOR (2/F 4 3/F)	E-24
CORRIDOR (4/F 4 5/F)	E-26
CORRIDOR (6/F 4 1/F)	E-28
CORRIDOR (8/F TO 11/F)	E-30
CORRIDOR (12/F TO 14/F)	E-32
CORRIDOR 4 LOCKER (2/F)	B-46
CORRIDOR (3/F)	B-48
CORRIDOR (4/F)	B-50
CORRIDOR (5/F 4 6/F)	B-52
CORRIDOR (7/F 4 8/F)	B-54
CORRIDOR (9/F TO 11/F)	B-56
CORRIDOR (12/F TO 14/F)	B-58
ELEVATOR CAB	ER-6, ER-8ER-10
EXTERIOR SITE	E1-E1-3E1-5E1-2E1-4E1-6
RECEPTACLE LOCATION	CCT.#
ELEC. S. CLOSET (G/F TO 9/F)	B-2
ELEC. N. CLOSET (12/F TO 9/F)	B-4
ELEC. N. CLOSET (10/F TO 14/F)	B-6
ELEC. N. CLOSET (22/F TO 32/F)	B-8
ELEV. LOBBY (P2 TO 8/F)	B-10
CORRIDOR (2/F TO 8/F)	B-12B-14B-16B-18B-20B-22B-24
CORRIDOR (2/F TO 5/F)	B-26B-28
ELEV. LOBBY (9 TO 14/F)	B-30
CORRIDOR (9/F TO 14/F)	B-32B-34B-36B-38
STAIR A (G/F) 4 J(9/F,6/F,3/F)	B-40
STAIR F (14/F)1(F,8/F,5/F,2/F)	B-42
STAIR H (14/F)1(F,8/F,5/F,2/F)	B-44
STAIR 'K' 4 MPH	R-2

- KEY NOTES - INSUITE:**
- DESIGNATED "LAUNDRY RECEPTACLE" AS DEFINED BY ESA CODE 26-110(a)(1), 26-120(b) AND ESA BULLETIN 26-26-0 (WITHIN 3m RADIUS OF LAUNDRY CLOSET). RECEPTACLE SHALL BE CONNECTED TO A DEDICATED CIRCUIT. SEE DETAIL #4 ON DWG. E-35.
 - SUITE DOOR CONTACTS AND GLASS BREAK DETECTOR WILL COMPLETE WITH INTRUSION ALARM SYSTEM THAT CONTACT TO THE CONCERGE STATION (TYPICAL)
 - FOR FAN COIL UNITS (FCU) ELECTRICAL CONTRACTOR TO SUPPLY AND INSTALL CONDUIT AND JUNCTION BOX FOR REMOTE THERMOSTAT. MECHANICAL CONTRACTOR SHALL SUPPLY, WIRE, TERMINATE WIRING AND MOUNT THERMOSTAT.
 - INSTALL SIDE-MOUNTED RECEPTACLE ON KITCHEN ISLAND CABINET.
 - SWITCHES, RECEPTACLES, ETC. TO BE INSTALLED AS TO NOT INTERFERE WITH THE OPENING AND OPERATION OF SLIDING DOOR.
 - TERRACE LIGHTING FIXTURE AND RECEPTACLE SHALL BE CENTERED ON PANEL (350MM FROM CENTRE OF DOOR MULLION). REFER TO ARCHITECTURAL ELEVATION.



MOUNTING HEIGHT SCHEDULE (TO TOP OF BOX)

OUTLET	SUITES	PUBLIC AREA
RECEPTACLE	400 MM AFF.	400 MM AFF.
TV OUTLET	400 MM AFF.	400 MM AFF.
TELEPHONE OUTLET	400 MM AFF.	400 MM AFF.
MULTI-PORT OUTLET	400 MM AFF.	400 MM AFF.
SWITCH	1200 MM AFF.	1200 MM AFF.
SECURITY PANEL	1200 MM AFF.	
SILENCE SWITCHES	1200 MM AFF.	
THERMOSTAT	1200 MM AFF.	1200 MM AFF.
INTERCOM		1200 MM AFF.
V.C. HANDSET		1200 MM AFF.
PULL STATION		1200 MM AFF.

- GENERAL NOTES - RESIDENTIAL:**
- ELECTRICAL DRAWINGS SHALL BE READ IN CONJUNCTION WITH MECHANICAL, STRUCTURAL, ARCHITECTURAL AND LANDSCAPE DRAWINGS.
 - CONTRACTOR SHALL RUN CABLES WITHIN CEILING SLAB OR ENCLOSURES TO RETAIN 2 HOUR FIRE PROTECTION RATING FOR ALL LOADS THAT CONNECT TO EMERGENCY POWER.
 - FIRE ALARM RISERS SHALL BE RUN IN 2 HOUR FIRE RATED ELECTRICAL CLOSET. REFER TO DWG. E-32 FOR RISER DIAGRAM AND DETAILS.
 - STAIRWAY WALL MOUNTED EMERGENCY LIGHT FIXTURES SHALL BE MOUNTED # 1" AFF. MIN.
 - FOR STORAGE ROOM VENTILATION SYSTEM, DIV. 16 TO PROVIDE CONDUIT, WIRING AND SWITCH (S) TO START/STOP FAN AND DAMPER. FAN AND 100V ACTUATOR TO BE SUPPLIED AND INSTALLED BY DIV. 15.
 - FOR UTILITY ROOM VENTILATION SYSTEM, DIV. 15 WILL PROVIDE LINE VOLTAGE THERMOSTAT (T) TO DIV. 16. DIV. 16 TO PROVIDE CONDUIT AND WIRING TO START/STOP FAN AND DAMPER VIA THERMOSTAT. FAN AND 100V ACTUATOR TO BE SUPPLIED AND INSTALLED BY DIV. 15.
 - FOR UNIT HEATER, DIV. 15 TO PROVIDE LINE VOLTAGE THERMOSTAT (T), DIV. 16 TO PROVIDE CONDUIT AND WIRING TO START/STOP UNIT HEATER.
 - REFER TO SPRINKLER DRAWINGS FOR FIRE PROTECTION DEVICE TO BE CONNECTED TO THE FIRE ALARM SYSTEM. THE DEVICE AND EQUIPMENT SHALL FORM AN INTEGRAL PART OF THE ELECTRICAL CONTRACT.
 - DIV. 16 SHALL SUPPLY AND INSTALL CONDUITS, WIRES AND INTERLOCK FANS TO MOTORIZED DAMPERS AND TO THE THERMOSTAT.
 - DIV. 16 SHALL SUPPLY AND INSTALL CONDUITS, WIRES AND INTERLOCK FANS TO MOTORIZED DAMPERS AND TO THE THERMOSTAT.
 - REFER TO SUITE PANEL SCHEDULES FOR INSUITE CIRCUIT ARRANGEMENT.
 - ALL DUELLING UNIT RECEPTACLES EXCEPT IN KITCHEN SHALL BE TAMPER PROOF.
 - PROVIDE GROUND FAULT PROTECTION FOR SUITE KITCHEN, AMENITY KITCHEN AND WASHROOM RECEPTACLES WITHIN 1500mm OF SINK.
 - PROVIDE TELECOMMUNICATION BOX C/W BUILT-IN RECEPTACLE FOR TELECOMMUNICATION. TELECOMMUNICATION BOX SHALL BE COMPLIANT WITH THE TELECOM SERVICE PROVIDER SPECIFICATION. REFER TO DETAIL #3 ON DWG. E-35 FOR TELECOM JUNCTION BOX INSTALLATION.
 - DRYER SENSOR TO START DRYER VENTILATION FAN AUTOMATICALLY WHEN DRYER IS RUNNING.
 - ALL SMOKE ALARMS WITHIN THE SUITE SHALL BE HARDWIRED TOGETHER AND TO A 15A 1P CIRCUIT BREAKER AHEAD OF OTHER LOADS.
- KEY NOTES - RESIDENTIAL - COMMON AREA:**
- FOR CIRCUITING, REFER TO TABLE #1.
 - PROVIDE ALARM SPEAKER, SMOKE DETECTOR AND RECEPTACLE AT EVERY THIRD FLOOR STAIR WELL STARTING FROM TOP FLOOR. AS PER TO DWG. E-32 FOR FIRE ALARM RISER DIAGRAM.
 - PROVIDE TELECOMMUNICATION BACKBOARD C/W 115V, 1A, 15A RECEPTACLE AS PER COMMUNICATION RISER DIAGRAM ON DWG. E-31.
 - CONTRACTOR SHALL REFER TO ELECTRICAL SINGLE LINE DIAGRAM ON DWG. E-30 AND SDP RISER ON DWG. E-31 FOR SDP LOCATIONS AND DISTRIBUTION.
 - PROVIDE CONDUIT AS PER RISER DETAIL #3 ON DWG. E-35 FOR TRISOMETER CONTROL SYSTEM.
 - REFER TO SUPERVISED VALVE AND FLOW SWITCH SCHEDULE ON DWG. E-33 FOR DETAILS ON TYPICAL FLOORS.
 - PROVIDE [Symbol] FOR ALL SUITES ON THIS FLOOR.

ELECTRICAL LEGEND

LIGHTING

- FLUORESCENT LIGHT FIXTURE, TYPE AS INDICATED
- LIGHT CONNECTED TO EMERGENCY POWER
- CEILING MOUNTED WALL MOUNTED LIGHT FIXTURE
- INCORPORATED LETTER DENOTES TYPE
- POLE MOUNTED LIGHT FIXTURE
- INCORPORATED LETTER DENOTES TYPE
- CARRIED CEILING LIGHT OUTLET
- TRACK LIGHT
- STRIP LIGHT
- UNDER CABINET FLUORESCENT LIGHT FIXTURE
- CEILING MOUNTED WALL MOUNTED EXIT SIGN
- INDIVIDUAL EMERGENCY LIGHT REFLECTOR HEAD
- EMERGENCY BATTERY PACK
- OCCUPANCY SENSOR POWER PACKS
- SINGLE/DOUBLE POLE SINGLE/DOUBLE THREE THROW TOGGLE SWITCH RESPECTIVELY
- 1/4" X 1/4" X 1/4" DENOTES 3-WAY 4-WAY FLOOR LIGHT, DIMMER SWITCHED LIGHT RESPECTIVELY
- MASTER LIGHTING SHUT-OFF SWITCH
- SENSOR WALL SWITCH FIR. SELF POWERED
- OCCUPANCY SENSOR CEILING MOUNTED

POWER

- REGULAR DUPLEX RECEPTACLE
- DUPLEX RECEPTACLE GROUND FAULT INTERRUPT
- 3-POLE 4-POLE DUPLEX RECEPTACLE
- SHAKE RECEPTACLE TYPE AND CONFIGURATION AS SPECIFIED FOR DRIVER
- CONNECTION FOR OVEN/COOKTOP
- MOVIE COUNTER DEVICE
- FLOOR MOUNTED DEVICES
- CEILING MOUNTED DEVICES
- DISCONNECT SWITCH NON-FUSED
- DISCONNECT SWITCH FUSED
- OPERATION STARTER
- FRACTIONAL MOTOR/FAN DIRECT CONNECTION
- DIRECT CONNECTION SINGLE PHASE
- DIRECT CONNECTION THREE PHASE
- THERMOSTAT
- DRYER SENSOR
- HEAT TRACE
- ELECTRIC HEATER
- ELECTRICAL PANEL / SECURITY PANEL

TELECOMMUNICATION

- TV/CABLE OUTLET
- TELEPHONE OUTLET
- TELEPHONE/CABLE (MULTI-PORT) OUTLET
- DATA OUTLET
- DATA/TELEPHONE OUTLET
- N SUITE TELECOM BOX C/W RECEPTACLE
- WIFI LOCATION
- VIDEO INTERCOM
- RADIO RECEIVER

SECURITY

- INTERCOM / ENTERPHONE
- INTERCOM WITH CAMERA
- PANIC BUTTON / PANIC INTERCOM STATION
- CARD READER
- AUTOMATIC RELEASE CARD ACCESS/RADIO RECEIVER
- ELECTRIC STRIKE
- MAGLOCK
- DOOR CONTACT / WINDOW CONTACT
- GLASS BREAK DETECTOR
- AUTOMATIC DOOR OPERATOR
- MOTION DETECTOR
- PUSH BUTTON
- SECURITY CAMERA

LIFE SAFETY

- FIRE ALARM SMOKE DETECTOR
- SMOKE ALARM
- FIRE ALARM DUST TYPE SMOKE DETECTOR
- FIRE ALARM HEAT DETECTOR
- FIXED TEMP. 68 °C DEGREE HEAT DETECTOR
- MOISTURE PROOF HEAT DETECTOR
- CO ALARM
- CONVENTION SMOKE 4 CO ALARM
- CO SENSOR / NO SENSOR
- FIRE ALARM MANUAL PULL STATION
- FIREFIGHTER'S HANDSET
- FIRE ALARM SPEAKER/SNOBEE WALL MTD.
- FIRE ALARM SPEAKER WALL MTD.
- FIRE ALARM SPEAKER/SNOBEE CEILING MTD.
- FIRE ALARM SPEAKER CEILING MTD.
- FIRE ALARM ANNUNCIATOR PANEL
- FIRE ALARM CONTROL PANEL

NO.	DATE	DESCRIPTION
0001	01/15/13	ISSUED FOR E1-E3
0002	01/15/13	ISSUED FOR E1-E3 SLASHING ACCORDING 11
0003	01/15/13	ISSUED FOR SECURITY REVISION
0004	01/15/13	ISSUED FOR E1-E3
0005	01/15/13	ISSUED FOR TENDER
0006	01/15/13	ISSUED FOR RISER
0007	01/15/13	RE-ISSUED FOR PERMIT
0008	01/15/13	ISSUED FOR PERMIT

DATE: 12/13/13

REVISIONS

CONTRACTOR MUST CHECK AND VERIFY ALL DIMENSIONS AND CONDITIONS FOR ALL WORK REFERRED TO IN THIS DRAWING. THE ENGINEER'S RESPONSIBILITY IS TO PROVIDE THE WORK. THIS DRAWING IS THE PROPERTY OF THE ENGINEER AND WILL BE RETURNED UPON COMPLETION OF THE WORK.

DRAWINGS ARE NOT TO BE SCALED

NOVA TREND CONSULTING

115 West Beaver Creek Road, Unit 31
Richmond Hill, Ontario L4B 3M1
Tel: 905-882-5445
Fax: 905-882-5441
Email: cad@novatrendeng.com

DRAWING TITLE
12/F FLOOR PLAN
ELECTRICAL LAYOUT

PROJECT FILE
ALEXANDRA PARK

38 CAMERON STREET, BLOCK II
TORONTO ONTARIO

DRAWN BY: S.O. **CHECKED BY:** S.T. **SCALE:** 1:50
DATE: FEB, 13 **PROJECT NUMBER:** 1313 **DRAWING NUMBER:** E-26 OF