



# GENERATOR SUBMITTAL

## DATA

Main Generator breaker to be LSI and 100% rated

Provide all conductor lugs per phase and neutral for all equipment as per Jay Electric Limited Scope of Work and BOM

PREPARED FOR:

Provide Emergency By-Pass function for single source by-pass.

Provide all relays and contacts as per Jay Electric Limited BOM.

**NOVATREND ENGINEERING GROUP LTD.**

THIS REVIEW IS MADE ONLY TO VERIFY CONFORMITY WITH THE GENERAL DESIGN CONCEPT AND DOES NOT IMPLY APPROVAL OF THE DETAIL DESIGN INHERENT IN THE SHOP DRAWINGS, RESPONSIBILITY FOR WHICH REMAINS WITH THE CONTRACTOR. THE CONTRACTOR IS RESPONSIBLE FOR ERRORS & OMISSIONS ON THE SHOP DRAWINGS, FOR INFORMATION RELATING SOLELY TO FABRICATION PROCESSES & CONSTRUCTION TECHNIQUES AND FOR MEETING ALL CONTRACTUAL REQUIREMENTS INCLUDING CO-ORDINATION OF FIELD DIMENSIONS & CO-ORDINATION OF THE WORK OF ALL HIS SUB-TRADES.

REVIEWED       REVIEWED AS NOTED  
 REVISE & RESUBMIT       REJECTED

Kevin Chen      2015-03-26  
 REVIEWED BY      DATE

# ALEXANDRA PARK SP

ELECTRICAL CONTRACTOR:

**Jay Electric Limited**  
 21 Kenview Blvd Unit # 2  
 Brampton, Ontario  
 L6T 5G7

Phone: 905-793-4000      Fax: 905-793-0074

Transfer switch assembly & function to comply with CSA C22.2 No. 178.1

Gen. Alternator – Provide 245 KW alternator with this set.

Provide all relays, contacts and devices as per notes #1, 2 and 3 on Jay Electric Limited Scope of Work.

JAY ELECTRIC LIMITED	
<input checked="" type="checkbox"/> Reviewed	
<input checked="" type="checkbox"/> Reviewed as noted	
<input type="checkbox"/> Resubmit	
DATE	REVIEWED BY
Feb. 25, 2015	Gary R Beer



**BILL OF MATERIALS**

**ALEXANDRA PARK SP**

**Job Number: B15-015 Submission 1**  
Feb. 19/15

**MODEL:**

**ITEM DESCRIPTION:**

NG200DWM

200kW @ 105 deg.C, 347/600 Volt, 60 Hz, 3 Phase, 4 Wire, Natural Gas Generator

**Installed Accessories:**

- CSA
- Unit Mounted Radiator, 40 deg. C, Ambient
- Block Heater, Thermostatically Controlled, c/w Isolation Valves
- Control Panel, Unit Mounted, MEC-20, complete to C282 specifications
- Safety Indicators and Shutdowns, including:
  - Generator Run Relay
  - Generator Fail Relay
  - Emergency Stop Button
- Line Circuit Breakers:
  - Emergency Power, 400A, /w Aux. Contact, 2x 3/0 - 2x 250 kcmil Lugs
- Electronic Governor
- Permanent Magnetic Generator (PMG)
- Automatic Battery Charger
- Battery Cables
- Flexible Fuel Lines (Steel Braided)
- Flexible Exhaust Connector
- Spring Isolators (Qty 4)
- 6" Hospital Plus Grade, Silencer
- Lead Acid Starting Battery(s) and rack(s)

**Accessories Supplied Loose:**

- TRANSFER SWITCH: TTI TS873 -400A-600V 3pl 4W, Single Sided Bypass, 2/0 - 250 MCM Lugs
- TRANSFER SWITCH: TTI TS870 -400A-600V 3pl 4W, No Bypass, 2/0 - 250 MCM Lugs
- Remote Annunciator

**Other Services:**

- First Fill of Lube Oil and Antifreeze/Coolant to suit
- 2- Year, Limited Warranty
- Standard Factory Test
- 2- Sets of Manuals
- Delivery to Site (Offloading by Others)
- Start-Up and Commissioning (Fuel by Others)

<b>JAY ELECTRIC LIMITED</b>	
<input checked="" type="checkbox"/> Reviewed <input type="checkbox"/> Reviewed as noted <input type="checkbox"/> Resubmit	
DATE	REVIEWED BY
Feb. 25, 2015	<i>Gary R Beer</i>

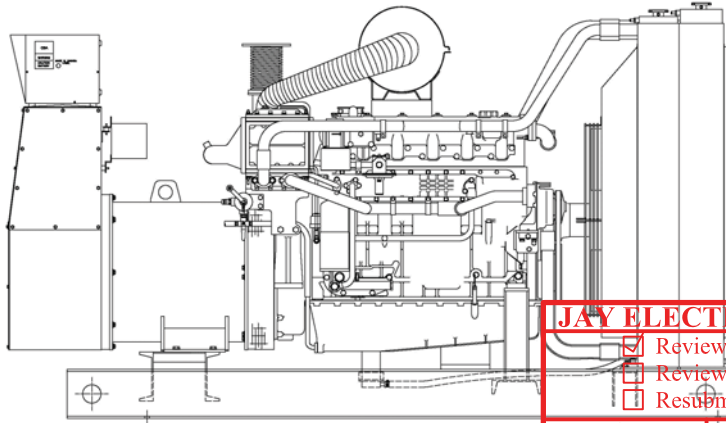

Stand-by Rating @ 150 deg.C

**200 kW @ 60 Hz**

**164 kW @ 50 Hz**

Prime Rating @ 125 deg.C

**175 kW @ 60 Hz**

**152 kW @ 50 Hz**

<b>JAY ELECTRIC LIMITED</b>	
<input checked="" type="checkbox"/>	Reviewed
<input type="checkbox"/>	Reviewed as noted
<input type="checkbox"/>	Resubmit
DATE	REVIEWED BY
Feb. 25, 2015	Gary R Beer

All generating sets and components are covered by Paramount Power Systems Ltd. for a limited one-year warranty. Optional warranty periods available upon request.

Each and every unit is tested prior to shipment to the customer, to prevent start-up and installation delays.

Engine and operational controls are designed to meet custom specifications.

Paramount Power Systems Ltd. is committed to quality products.

Paramount Power Systems Ltd. accepts 100% of nameplate ratings as per NFPA 110.

Accessories are custom fitted to meet customers needs and requirements.

MODEL	VOLTAGE	Hz	Ph	STAND-BY CURRENT	STAND-BY RATING	PRIME RATING
NG200DWMA6	120/208	60	3	694	200 kW	175 kW
*NG200DWMB6	120/240	60	1	729 @ 1.0 pf	175 kW	165 kW
NG200DWMC6	127/220	60	3	656	200 kW	175 kW
NG200DWMD6	139/240	60	3	601	200 kW	175 kW
NG200DWME6	220/380	60	3	379	200 kW	175 kW
NG200DWMF6	240/416	60	3	347	200 kW	175 kW
NG200DWMG6	277/480	60	3	300	200 kW	175 kW
<b>NG200DWMH6</b>	<b>347/600</b>	<b>60</b>	<b>3</b>	<b>240</b>	<b>200 kW</b>	<b>175 kW</b>
NG160DWMI5	110/190	50	3	622	164 kW	152 kW
NG160DWMJ5	110/220	50	3	537	164 kW	152 kW
NG160DWMK5	115/200	50	3	591	164 kW	152 kW
NG160DWML5	120/208	50	3	568	164 kW	152 kW
NG160DWM5	220/380	50	3	311	164 kW	152 kW
NG160DWMN5	230/400	50	3	295	164 kW	152 kW
NG160DWMO5	240/416	50	3	284	164 kW	152 kW

\* Other ratings are available, consult factory

Above ratings: Class H

**ENGINE TECHNICAL DATA**

**60 Hz**

**50 Hz**

Model:.....	GE12TIR	
Type:.....	4 Cycle, Water-cooled	
Aspiration:.....	Turbocharged- Water to Air Intercooled	
Cylinder Arrangement (Number, Inline, V, etc.):.....	Inline-6, Replaceable wet liner	
Combustion:.....	Stoichiometric, Premixed and Spark Ignited	
Displacement- Cu.In. (lit.):.....	674.5 (11.05)	
Bore- in. (mm) x Stroke- in. (mm):.....	4.84 (123) x 6.1(155)	
Compression Ratio:.....	10.5 : 1	
Firing Order:.....	1-5-3-6-2-4	
Ignition Timing:.....	13 deg. BTDC	
Trigger System:.....	Mag. sensor/Trigger Wheel/Hall-effect (0.75 / -0.25mm air gap)	
Carburetor:.....	Impco 200M Varifuel Carburetor	
Rated RPM:.....	1,800	1,500
Maximum Power at Rated RPM- PS (kW):.....	306 (225)	272 (200)

\*excludes fan losses

**INSTALLATION DATA**

<b>Dimensions and Weights</b>		
Length- in. (mm):.....	119.5 (3039)	
Width- in. (mm):.....	45.5 (1151)	
Height- in. (mm):.....	67.5 (1716)	
Weight- lbs. (kg):.....	4,900 (2227)	
<b>Liquid Capacity</b>		
Total Oil System- gal. (lit.):.....	6.61 (25)	
Engine Jacket Water Capacity- gal. (lit.):.....	4.63 (21)	
System Coolant Capacity- gal. (lit.):.....	13.2 (60)	
<b>Electrical System</b>		
Electric Volts DC.....	24	
Starting Battery Capacity- Recommended AH:.....	150	
<b>Exhaust System</b>		
Gas Temp.- Stack F (C):.....	1,076 (566)	1,036 (545)
Gas Volume at Stack Temp.- CFM (m3/min.):	954 (27)	813 (23)
Maximum Allowable- Back Pressure- in. Hg (mmH2O):.....	1.73 (600)	1.73 (600)
Emissions- HC g/kW-hr:.....	consult factory	consult factory
Emissions- CO g/kW-hr:.....	consult factory	consult factory
Emissions- NOx g/kW-hr:.....	consult factory	consult factory
<b>Cooling System</b>		
Ambient Capacity of Radiator F (C):.....	104 (40)	104 (40)
Maximum Allowable Back Pressure on Radiator Exhaust- in. H2O (kPa):.....	0.5 (0.12)	0.5 (0.12)
Water Pump Capacity- gpm (lit./min.):.....	68.3 (310)	57.3 (260)
Heat Rejection to Coolant- kW (Kcal/sec.):.....	194.7 (46.5)	163.3 (39.0)
Heat Rejection to CAC- kW (Kcal/sec.):.....	13 (3.1)	7.6 (1.8)
<b>Air Requirements</b>		
Aspirating- CFM (m3/min.):.....	555 (15.7)	460 (13)
Air Flow Required for Radiator Cooled Unit- CFM (m3/min.):.....	12,720 (360)	9,540 (270)
<b>Gas Consumption: Standby- BTU/hr.:</b>		
@ 100% of Power Rating:.....	3,000,000	43.4 (31.7)
<b>Gas Pressure: Standby- Inches W.C.:</b>		
@ 100% of Power Rating:.....	18-20	34.3 (25.0)
<b>Deration:</b>		
Altitude: 2% per 500m above 1,600m (up to 3,000m) Above 3,000m, consult factory.		26.3 (19.2)

**JAY ELECTRIC LIMITED**

Reviewed  
 Reviewed as noted  
 Resubmit

DATE	REVIEWED BY
Feb. 25, 2015	Gary R Beer

Temperature: 1% per 10 deg.C above 20 deg.C (for altitudes up to 500m)  
 Consult factory for different temperatures above 500m.

# STANDARD EQUIPMENT

## CONTROL PANEL

- Model UCS200C, Microprocessor Controlled
- Backlit LCD screen with alpha-numeric readout
- Automatic Start Capability
- Digital AC metering display
  - a) Three Phase Voltage
  - b) Three Phase Current
  - c) Output Frequency
- Digital Engine gauge display
  - a) Oil Pressure
  - b) Engine Temp.
  - c) Battery Voltage
  - d) Hourmeter
  - e) Tachometer
- Timers
  - a) Engine Start
  - b) Cooldown
  - c) Oil Bypass
  - d) Over Crank
  - e) Cycle Crank

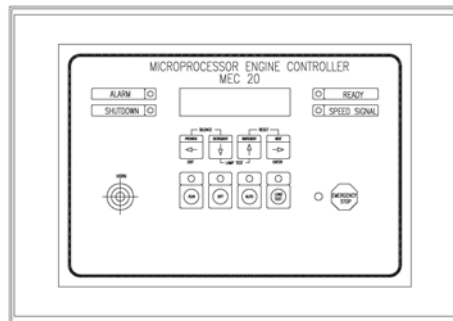

## ENGINE SPECIFICATIONS

- Air Filter
- Mechanical Lift Pump
- Electronic Governor
- Full Flow Oil Filter, Spin-on
- Dry Exhaust Manifold
- Blower Fan and Fan Drive
- Unit Mounted Radiator
- Air to Air Intercooled
- Belt Driven Coolant Pump
- Turbocharged
- Battery Charging Alternator (24V DC)
- Belt and Fan Guards
- EPA Certified

## ALTERNATOR SPECIFICATIONS

- MagnaMax AC Generator
- Brushless Design
- Permanently Lubricated Single Ball Bearing, Directly Coupled with Flexible Plates
- Class H Insulation
- CSA Approved and Manufactured to NEMA MG1-22
- Generator is Self Ventilated
- Drip Proof Construction
- PMG (Permanent Magnetic Generator)
- Control Switches
  - a) Run/Off/Auto/Load Test
  - b) Horn Silence
  - c) Lamp Test and Fault Reset
  - d) Emergency Stop
- Audible Alarm Horn
- Shutdown Safety
  - a) Over Crank, Over Speed
  - b) Loss of Speed Signal, Emergency Stop
  - c) Low Oil Pressure, High Engine Temp.
  - d) Low Coolant Level, Over Voltage
- Alarm Safety
  - a) Switch Not in Auto
  - b) Low Fuel Level\*
  - c) Low Engine Temp.
  - d) Pre-Low Oil Pressure
  - e) Pre-High Engine Temp.
  - f) Low and High Battery Voltage
  - g) Battery Charger Failure\*
  - h) Weak Battery
  - i) Under Voltage
  - j) Under Frequency
  - k) Over Frequency
  - l) Over Current
  - m) Tank Rupture\*
- Generator Running Output Contact
- Common Shutdown Output Contact
- Common Alarm Output Contact

<b>JAY ELECTRIC LIMITED</b>	
<input checked="" type="checkbox"/> Reviewed <input type="checkbox"/> Reviewed as noted <input type="checkbox"/> Resubmit	
DATE	REVIEWED BY
Feb. 25, 2015	<i>Sary R Beer</i>

## STANDARD FEATURES & OPTIONS

### CONTROL PANEL

UCS200C is standard and capable of the following additional features:

- Remote annunciation with buzzer and silencing switch -Optional
  - a) Multi LED Indication (20 max.)
- Extra customer input alarms (8 max.) -Optional
- Dry contact kit for customer connections
- Over and under voltage shutdowns/alarms
- Over and under frequency shutdowns/alarms

### ENGINE AND GENERATOR

- Block Heater and Therostat
- Line Circuit Breaker -Optional
- Shunt Trip -Optional
- Auxilliary Contacts with Breaker -Optional
- Oversized Generator -Optional
- Over Voltage Protection
- Spring Isolators -Optional
- Extended Warranty -Optional

### OPEN UNIT

- Exhaust Silencer -Optional
- Flexible Exhaust Connector
- "Y" -Connector

### ENCLOSED UNIT (Optional)

- Weather Proof Housing
- Sound Attenuated Housing
- Walk-in Enclosure

### FUEL SYSTEM -Diesel

- Main Fuel Tank -Optional
- Day Tank -Optional
- Sub-Based Fuel Tank -Optional
  - a) Single Wall
  - b) Double Wall
- Fuel Pumps and Controls -Optional
- Flexible Fuel Lines (ULC)
- Fuel/Water Separator -Optional

### FUEL SYSTEM -Natural Gas

- Dual Solenoid, Shut-off Valve
- Low Pressure Switch
- High Pressure Switch
- Gas Filter
- Flexible Fuel Line (CSA)

### ELECTRICAL SYSTEM

- Starting Batteries & Racks
- Positive, Negative & Jumper Cables
- Automatic Battery Charger, 24V-10A
- Battery Warmer Blanket -Optional

<b>JAY ELECTRIC LIMITED</b>	
<input checked="" type="checkbox"/>	Reviewed
<input type="checkbox"/>	Reviewed as noted
<input type="checkbox"/>	Resubmit
DATE	REVIEWED BY
Feb. 25, 2015	<i>Gary R Beer</i>

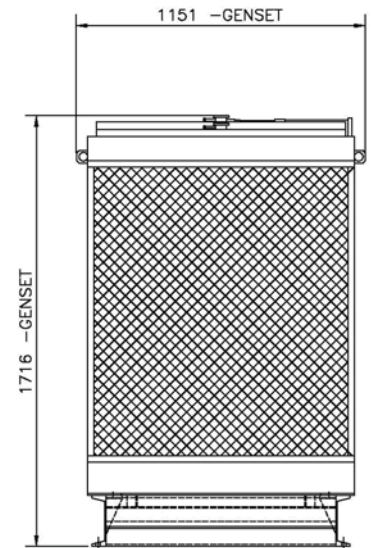
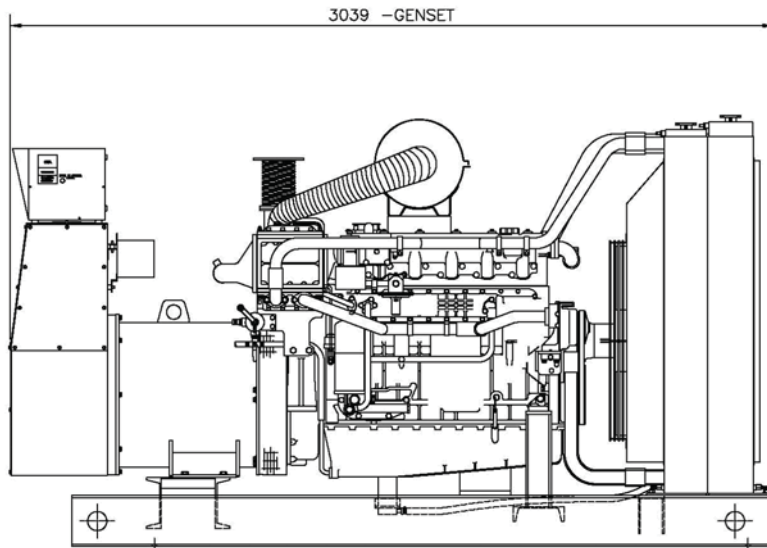

**Two Year Limited Warranty**  
**Diesel Engine Driven Generators**

**Industrial Standby Power Systems Policy**

Paramount Power Systems Ltd. Warrants to the original purchaser any goods manufactured, or sold by it, to be free from defects in material and/or workmanship for a period of 24 months from Start-up Notification Date and/or 1500 hours of operation, (or whichever occurs first). Warranty periods for Generator sets without registered Start-up Notifications will begin from the factory date inscribed into the serial number.

The warranty is limited to repair and/or replacement upon inspection of any defective parts by Paramount Power Systems or an authorized representative of Paramount Power Systems. This warranty is extended to the first user only and no warranty is made or authorized to be made assignable on resale by the initial purchaser of such equipment. The warranty includes a pass-through warranty from the engine, alternator, and controller manufacturers for whatever period and warranty is in effect by the manufacturer at that time. The above warranty only extends to applications and installations which are considered standard by Paramount Power.

During the standard or extended warranty period, Paramount Power Systems, reserves the right to repair or replace any part which, upon inspection, is found to be defective under normal use and operation. This warranty does not include normal maintenance and service and does not apply to a generator set, engine, and/or other components which have been subject to improper or unauthorized installation, operation, misuse, negligence, overloading, overspeeding, improper maintenance and repair or storage.

Paramount Power Systems Ltd. will not be responsible under this warranty for any cost of shipping or transportation of the equipment or parts thereof to or from Paramount Power System offices. Further, Paramount Power is not liable for loss of time, inconvenience, incidental expenses such as telephone calls, labor or material charges incurred in connection with the removal or replacement of equipment or any other incidental or consequential damages.

Any replacement part that is equivalent with respect to the functional performance of the original part may be used in the performance of any maintenance or repairs. If non-genuine parts are used and cause or substantially contribute to a failure, that failure may not be covered by warranty. Distributors and/or dealers authorized to perform warranty repairs will use only genuine replacement parts to cover any damaged on non-functioning original equipment.

Parts found to be defective during the official warranty period, must be returned to Paramount Power Systems at 2423 Anson Drive, Mississauga, Ontario, L5S 1G1, Canada, during the warranty period, freight prepaid by customer. Failure to provide the damaged or non-functioning part for review will thereby nullify any warranty that may exist at that time on such part(s) and may affect warranty on the entire generator set. Submission of a claim does not obligate Paramount Power Systems or their Distributors or Dealers to accept such claim in full or in part. Any claims that are filed by the original purchaser must be accompanied by proof of purchase, including date of purchase and/or date of commissioning.

Replacement parts found to be defective by Paramount Power Systems will be fixed or replaced, at manufacturers discretion, and returned to original purchaser. Any parts being replaced must be handled by a recognized generator repair facility. Any person (s) repairing or replacing such parts must be regularly engaged in that business, failure by the purchaser to utilize a qualified repair facility will nullify in part or in full any warranty on the generator set.

**This Warranty Shall Not Apply To:**

1. Cost of maintenance, adjustments, installation, and Start Up.
2. Failures due to normal wear, accident, misuse, abuse, negligence, improper installation, lack of maintenance, unauthorized modifications, the use of add-on or modified parts, improper storage, and improper or contaminated fuel.
3. Products which are altered or modified in a manner not authorized by manufacturer in writing.
4. Failure of goods caused by defects in the system or application in which goods are installed.
5. Telephone, fax, or other communication expenses.
6. Living and travel expenses of person (s) performing service except as recommended by manufacturer. Contact Paramount Power Systems for details.
7. Rental equipment used while warranty repairs are being performed.
8. Overtime Labor requested by purchaser.
9. Starting Batteries.
10. The cost of Air Freight or other special shipping methods for parts over and above standard ground transportation.

Paramount Power Systems hereby disclaims any and all implied warranties, including but not limited to those of merchantability and fitness for a particular purpose to the extent permitted by the law. The duration of any implied warranties which cannot be disclaimed is limited to the time period (one year) as specified in this policy. Liability for consequential, incidental, or special damages under any and/or all warranties is excluded to the extent permitted by law.

<b>JAY ELECTRIC LIMITED</b>	
<input checked="" type="checkbox"/> Reviewed	
<input type="checkbox"/> Reviewed as noted	
<input type="checkbox"/> Resubmit	
DATE	REVIEWED BY
Feb. 25, 2015	Gary R Beer

**"Power to Continue"**

# MAGNAMAXDVR® GENERATORS

RANDOM WOUND

## TYPICAL SPECIFICATION

The generator shall be manufactured by Marathon Electric Manufacturing Corporation and of the MagnaMAXDVR® design. It shall meet all requirements of NEMA MG-1, Parts 16 and 22, in design, performance and factory test procedures. The generator and regulator will be C.S.A. listed. The regulator shall be factory wired and tested with the generator.

### CONSTRUCTION AND BEARINGS

The unit shall be fully guarded per NEMA MG-1-1.25.4 as a minimum. Optional drip covers can be requested to meet requirements for IP-22 and IP-23 on stock units. Other ratings are available as special build-up designs and should be requested from the factory.

Cast iron end brackets and fabricated steel frames shall be used.

Bearings shall be pre-lubricated, double shielded, ball type, single row conrad, C3 fit with provisions for adding and/or changing grease. The ability to grease through extended supply and relief tubes is available as an option. Minimum B-10 bearing life shall be 40,000 hours for single bearing units.

The grease utilized shall be Polyrex EM or equivalent.

<b>JAY ELECTRIC LIMITED</b>	
<input checked="" type="checkbox"/>	Reviewed
<input type="checkbox"/>	Reviewed as noted
<input type="checkbox"/>	Resubmit
DATE	REVIEWED BY
Feb. 25, 2015	Gary R Beer

### PMG EXCITATION SYSTEM

The generator shall be equipped with a 300/250 Hz permanent magnet generator excitation system. Both the PMG and the rotating brushless exciter shall be mounted outboard of the bearing. The system shall supply a minimum short circuit support current of 300% of the rating (250% for 50 hertz operation) for 10 seconds. The rotating exciter shall use a three phase full wave rectifier assembly with hermetically sealed silicon diodes protected against abnormal transient conditions by a multi-plate selenium surge protector. The diodes shall be designed for safety factors of 5 times voltage and 3 times current.

### INSULATION SYSTEM

The insulation system shall be UL recognized meeting the construction requirements of UL-1446 and shall be suitable for submission as a component for UL2200 certification. The insulation system of both the rotor and stator shall be of NEMA Class H materials or better and shall be synthetic and non-hygroscopic. The stator winding shall be given multiple dips and bakes of varnish, plus a final coating of epoxy for extra moisture and abrasion resistance. The rotor shall be layer wound with thermosetting 100% solids epoxy between each layer, plus a final coating of epoxy for moisture and abrasion resistance.

**MAIN ROTOR**

The main rotating field shall be of Unirotor® construction, consisting of one piece, four pole laminations. Dovetails, cross bolts and other pole to shaft connection means are not acceptable. In addition, the amortisseur winding and field pole coil supports shall be integrally die cast with the rotor laminations to form a unitized rotor core. Fabricated and welded or brazed amortisseur windings and coil supports are not acceptable. The rotor core shall be shrunk fit and keyed to the shaft.

The rotating assembly shall be dynamically balanced to less than 2 mils peak to peak displacement, and shall be designed to have an over speed withstand of 125% of rated speed for 15 minutes when operating at stable rated operating temperature.

**STATOR WINDING**

The stator winding shall be of 2/3 pitch design to eliminate the third harmonic and shall incorporate a one slot skew to minimize slot harmonics. Windings shall be random wound and lashed at the end turns to provide superior mechanical strength.

**TEMPERATURE RISE**

The temperature rise of both the rotor and stator shall be measured by the resistance method and shall be in accordance with the applicable sections of NEMA MG-1, Parts 16 and 22, BS-5000, or C.S.A. C22.2, for the type of service intended.

**VOLTAGE REGULATOR**

The DVR2000 voltage regulator shall be a digital, microprocessor design with solid state voltage build-up. No voltage build-up relay or other relays are acceptable. The unit shall be encapsulated for humidity and abrasion protection. The regulator shall include 1/4% regulation, true volts per hertz operation with adjustable cut in, loss of sensing continuity shutdown, over excitation shutdown, three phase RMS sensing, over voltage protection, and provisions for parallel operation.

**PERFORMANCE**

The voltage regulation shall be 1/4% from no load to full load and 5% frequency variation. Regulator drift shall be less than 1/2% per 72°F (40°C) ambient temperature change. The voltage regulator shall be a static-type using non-aging silicon controlled rectifiers, with electromagnetic interference suppression to MIL-STD-461 C, part 9, when mounted in the generator conduit box.

The waveform harmonic distortion shall not exceed 5% total RMS measured line to line at full rated load.

The TIF factor shall not exceed 50.

<b>JAY ELECTRIC LIMITED</b>	
<input checked="" type="checkbox"/> Reviewed <input type="checkbox"/> Reviewed as noted <input type="checkbox"/> Resubmit	
DATE	REVIEWED BY
Feb. 25, 2015	Gary R Beer

### **VENTILATION**

The generator shall be self-ventilated and have a one-piece, cast aluminum alloy, unidirectional internal fan for high volume, low noise air delivery. Air flow shall be from opposite drive end through generator to drive end. The exciter shall be in the air flow.

### **CONDUIT BOX**

Load connections shall be made in the front end mounted conduit box. The generator construction will allow connection to the load through the top, bottom or either side of the conduit box.

The conduit box shall be constructed of heavy gauge sheet steel, capable of supporting up to 240 pounds of accessory control equipment. The conduit box shall contain two compartments; one housing the rotating rectifier and PMG; and the other the connection area and regulator. This is to separate the rotating elements from the load connection and voltage regulator adjustments.

The regulator shall be mounted on the inside of the conduit box panel allowing access to adjust the regulator through a swinging dust cover from the outside of the conduit box, therefore avoiding the higher voltage generator terminals on the inside of the conduit box.

### **VERIFICATION OF PERFORMANCE**

All certified performance and temperature rise test data submitted by the generator manufacturer are to be the result of the actual test of the same or duplicate generators. Temperature rise data shall be the result of loaded, rated power factor heat runs at the rated voltage and hertz. All performance testing shall be done in accordance with MIL-STD-705 and/or IEEE Standard-115.

<b>JAY ELECTRIC LIMITED</b>	
<input checked="" type="checkbox"/> Reviewed	
<input type="checkbox"/> Reviewed as noted	
<input type="checkbox"/> Resubmit	
DATE	REVIEWED BY
Feb. 25, 2015	Gary R Beer

**TYPICAL SUBMITTAL DATA**

MODEL : 432RSS4256

BASE MODEL: 432RSS4256

Winding H-SG 430055

1/19/2001

Submittal Data: 600 Volts\*, 204.8 kW, 256 kVA, 0.8 P.F., 1800 RPM, 60 Hz, 3 Phase

Kilowatt ratings at		1800 RPM		60 Hertz		4 LEADS		Dedicated voltage 3 phase	
kW (kVA)		3 Phase		0.8 Power Factor		Dripproof or Open Enclosure			
Voltage*	Class B	Class F				Class H			
	80° C Ⓞ Continuous	90° C Ⓞ Lloyds	95° C Ⓞ ABS	105° C British Standard	105° C Continuous	130° C Ⓞ Standby	125° C British Standard	125° C Continuous	150° C Ⓞ Standby
600	170 (213)	185 (231)	190 (238)	200 (250)	200 (250)	205 (256)	205 (256)	210 (263)	215 (269)

ⓄRise by resistance method, Mil-Std-705, Method 680.1b.

British Standard Rating per BS 5000

Submittal Data: 600 Volts*, 204.8 kw, 256 kVA, 0.8 P.F., 1800 RPM, 60 Hz, 3 Phase						STD. CONNECTION	
Mil-Std-705B			Mil-Std-705B				
Method	Description	Value	Method	Description	Value		
301.1b	Insulation Resistance	>1.5 Meg	505.3b	Overspeed	2250 RPM		
302.1a	High Potential Test		507.1c	Phase Sequence CCW-ODE	ABC		
	Main Stator	2200 Volts	508.1c	Voltage Balance, L-L or L-N	0.20%		
	Main Rotor	1500 Volts	601.4a	L-L Harmonic Maximum - Total (Distortion Factor)	5.0%		
	Exciter Stator	1500 Volts	601.4a	L-L Harmonic Maximum - Single	3.0%		
	Exciter Rotor	1500 Volts	601.1c	Deviation Factor	5.0%		
	PMG Stator	1500 Volts	---	TIF (1960 Weightings)	< 50		
401.1a	Stator Resistance, Line to Line High Wye Connection	0.0712 Ohms	652.1a	Shaft Current	< 0.1 ma		
	Rotor Resistance	0.19 Ohms		Main Stator Capacitance to Ground	0.01 mfd		
	Exciter Stator	22.5 Ohms		<b>Additional Prototype Mil-Std Methods are Available on Request.</b>			
	Exciter Rotor	0.022 Ohms	--	Generator Frame	432		
	PMG Stator	2.1 Ohms	--	Type	MAGNAMAXDVR		
410.1a	No Load Exciter Field Amps at 300/600 Volts Line to Line	0.68 A DC	--	Insulation	Class H		
420.1a	Short Circuit Ratio	0.570	--	Coupling - Single Bearing	Flexible		
421.1a	Xd Synchronous Reactance	2.7 p.u. 3.802 ohms	--	Amortisseur Windings	Full		
422.1a	X2 Negative Sequence React.	0.235 pu	--	Excitation Ext. Voltage Regulated, Brushless			
423.1a	X0 Zero Sequence Reactance	0.331 ohms 0.041 pu	--	Voltage Regulator	DVR2000		
425.1a	X'd Transient Reactance	0.058 ohms 0.139 pu	--	Voltage Regulation	0.25%		
426.1a	X''d Subtransient Reactance	0.196 ohms 0.128 pu	--	Cooling Air Volume	1130 CFM		
--	Xq Quadrature Synch. React.	0.18 ohms 1.085 pu 1.528 ohms	--	Heat rejection rate	1077 Btu's/min		
427.1a	T'd Transient Short Circuit Time Constant	0.068 sec.	--	Full load current	246 amps		
428.1a	T''d Subtransient Short Circuit Time Constant	0.01 sec.	--	Minimum Input hp required	299.9		
430.1a	T'do Transient Open Circuit Time Constant	1.15 sec.	--	Efficiency at rated load :	91.5%		
432.1a	Ta Short Circuit Time Constant of Armature Winding	0.013 sec.	--	Full load torque	875 Lb-ft		

(3) Excitation support system or PMG required to sustain short circuit currents.

\* Voltages refer to wye (star) connection, unless otherwise specified.

### TYPICAL DYNAMIC CHARACTERISTICS

MODEL : 432RSS4256  
 BASE MODEL: 432RSS4256  
 Winding H-SG 430055  
 Submittal Data: 600 Volts\*, 204.8 kW, 256 kVA, 0.8 P.F., 1800 RPM, 60 Hz, 3 Phase

**JAY ELECTRIC LIMITED**  
 Reviewed  
 Reviewed as noted  
 Resubmit  
 DATE: Feb. 25, 2015  
 REVIEWED BY: Gary R Beer

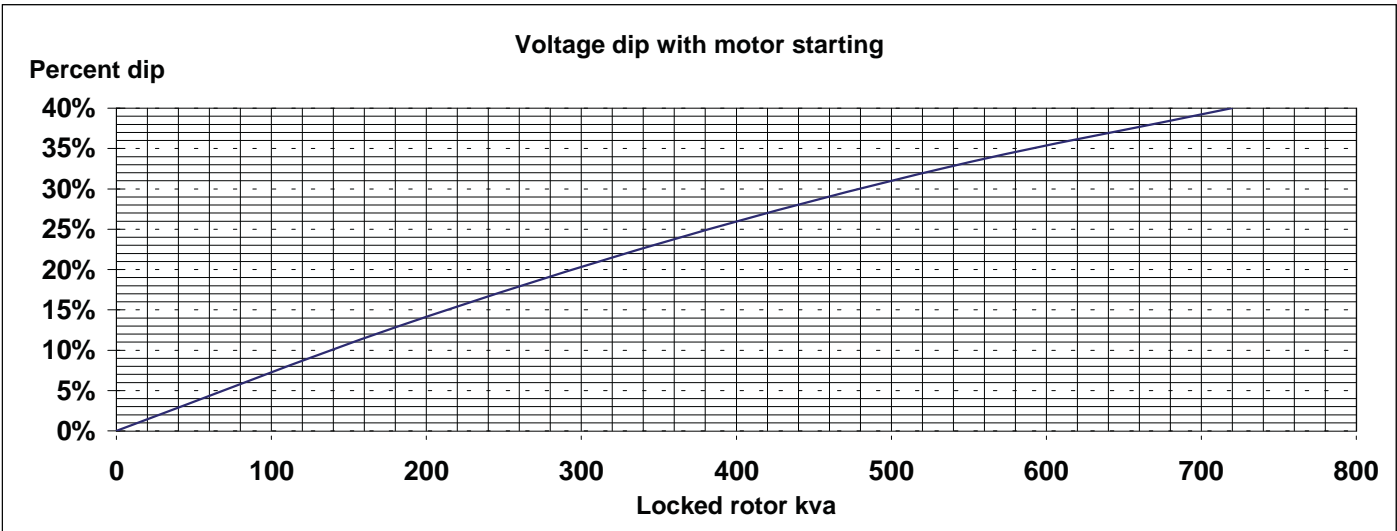
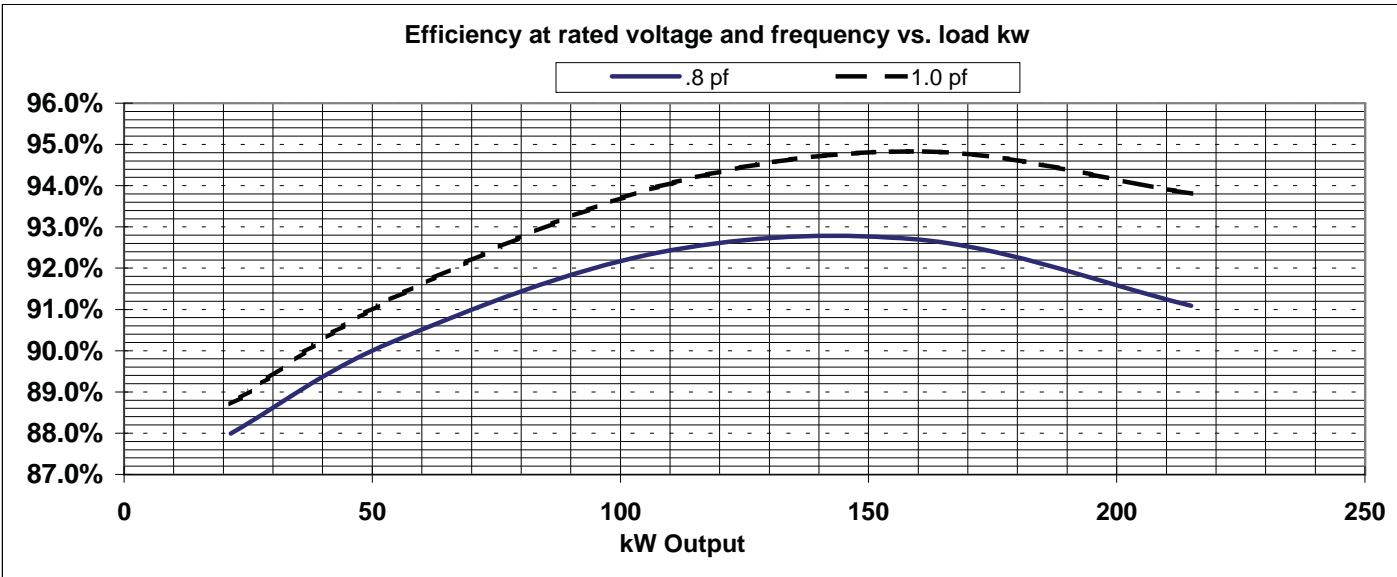
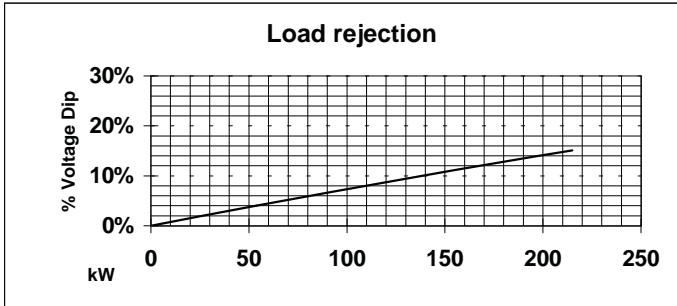
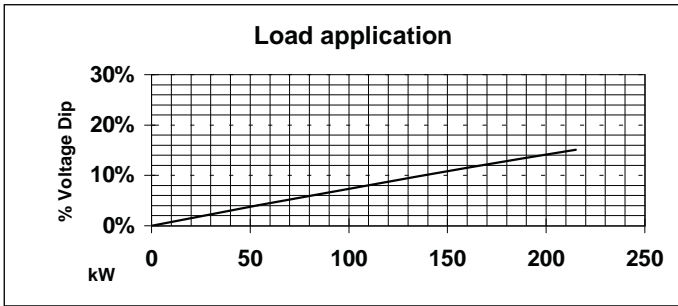
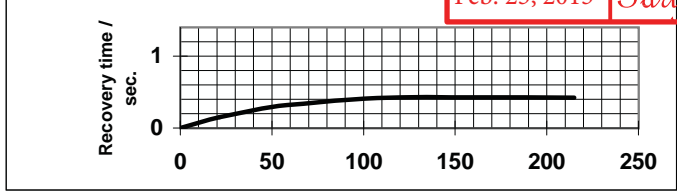
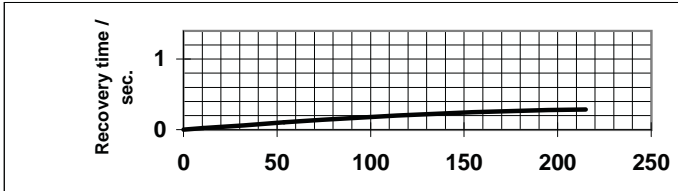

# MARATHON ELECTRIC GENERATORS

## DECREMENT CURVE

<b>JAY ELECTRIC LIMITED</b>	
<input checked="" type="checkbox"/> Reviewed	<input type="checkbox"/> Reviewed as noted
<input type="checkbox"/> Resubmit	
DATE	REVIEWED BY
Feb. 25, 2015	Sary R. Beer

Customer :  
 Order :  
 Model : 432RSS4256  
 Phase : 3  
 Hertz : 60  
 Volts : 600  
 RPM : 1800

Prepared by :  
 Date : 11/04/09  
 BASE MODEL: 432RSS4256  
 STD. CONN.

KVA : 256  
 KW : 204.8  
 P.F. : 0.8

Full Load Current : 246 amps  
 Steady State S.C. Current : 738 amps  
 Max. 3 ph. Symm. S.C. Current : 1922 amps

**INCLUDES EXCITATION SUPPORT (PMG)**

Symmetrical Component values, Maximum Asymmetrical Values Are 1.732 Times Symmetrical Values

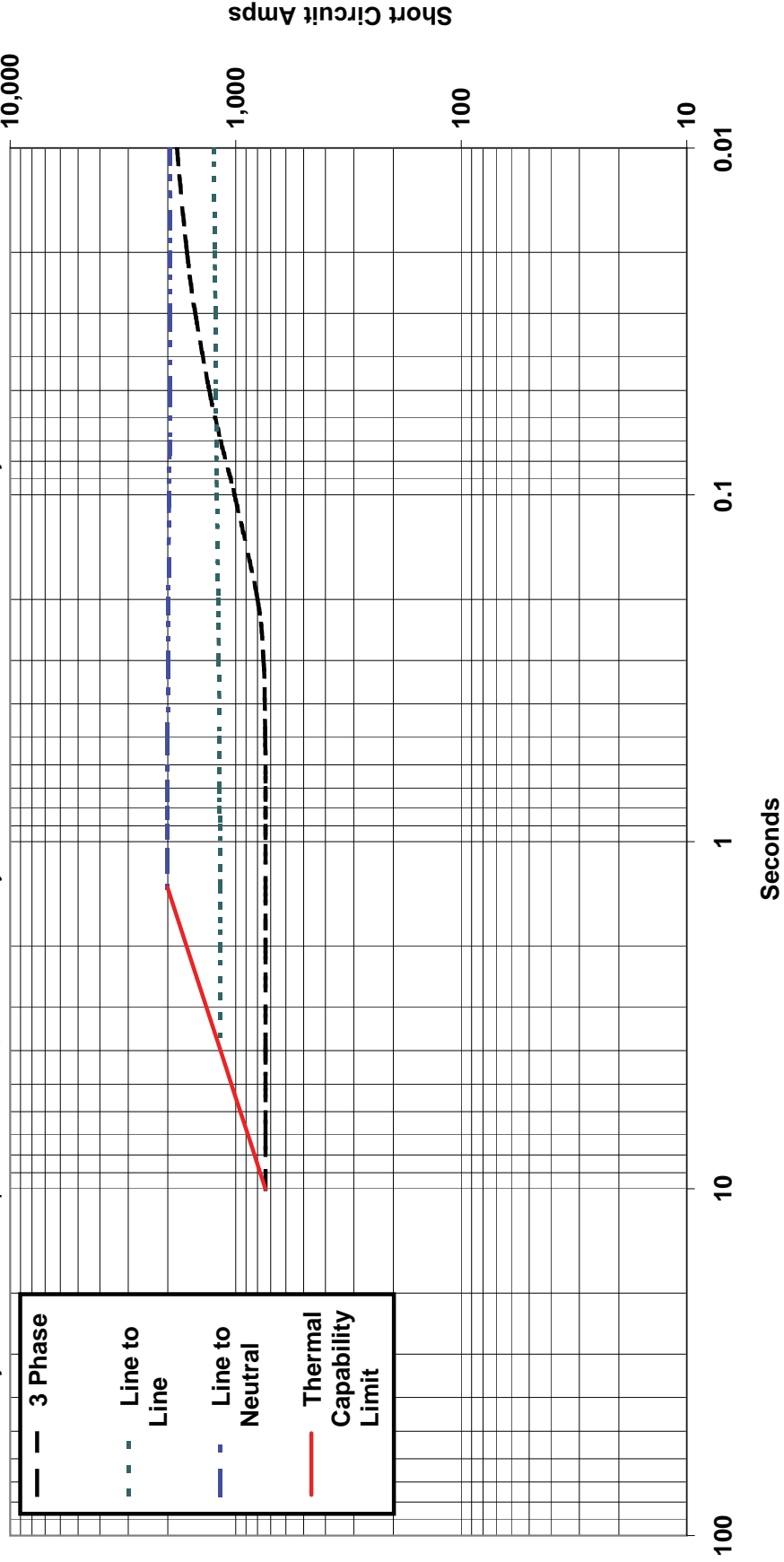

# DVR<sup>®</sup> 2000E

## Enhanced Digital Technology Voltage Regulator

### Advanced Features:

#### True RMS Sensing – One or Three Phase

Connect the sensing mode you prefer. Senses 95 to 600 volts  $\pm 10\%$  at 50/60 hertz. Patented circuitry senses true RMS voltage rather than average for superior load regulation.

#### Soft-Start Ramp on Initial Start-Up

Controlled increase to rated voltage. Limits overshoot of voltage during voltage build-up.

#### Engine Unloading

Monitors the rate of frequency change during transient conditions. Provides additional voltage dip during speed drop to allow engine to recover faster.

#### Oversvoltage Shutdown

Provides generator protection during sustained oversvoltage. The oversvoltage point is preset at 20% over normal generator operating voltage, with a preset timeout of 0.75 seconds.

#### VAR/PF Controller

Model DVR<sup>®</sup>2000EC (optional) provides control when paralleled to utility power. VAR or PF control can be selected or changed by regulator adjustment.

#### Encapsulated Design

Maximum protection against moisture or abrasive contamination, which can lead to early regulator failure. Tested to MIL-STD-705, Method 711.1C. Salt fog tested to MIL-STD-810E.

#### Auto/Manual Mode

Exciter field current can be controlled by the regulator or manually set at a fixed value.



CSA Approved

Solid State Voltage Build-Up  
eliminates voltage build-up relays  
with contacts that arc and fail.

ISO 9002 Certified

## Another First by the Generator Leader



<b>JAY ELECTRIC LIMITED</b>	
<input checked="" type="checkbox"/> Reviewed	
<input type="checkbox"/> Reviewed as noted	
<input type="checkbox"/> Resubmit	
DATE	REVIEWED BY
Feb. 25, 2015	Sary R Beer

# DVR<sup>®</sup>2000E Regulator Specifications

**Voltage Regulation.** 0.25% for precise voltage control on most applications. Voltage drift less than 0.5% for 40°C ambient temperature change (15 to 70°C range).

**Output Power.** 3.0 ADC, 75 VDC, 225 watts, maximum continuous rating; 7.5 ADC, 150 VDC, 1125 watts forcing for one (1) minute.

**Exciter Field DC Resistance.** Nominal hot resistance 18 to 25 ohms.

**Voltage Adjustment.** Minimum of  $\pm 10\%$  of nominal voltage range. Remote adjustment can be made up to 150 feet from voltage regulator.

**50 or 60 Hz Operation.** No reconnection required for frequency change.

**Power Input.** 180–240 volts AC, 200–360 hertz PMG supply.

**Wide Operating Temperature Range.** -40°C to +70°C covers all normal operating environments. Regulator “latches” off when +70°C is exceeded.

**Loss of Sensing Shutdown.** Protects the generator against uncontrolled voltage output when the sensing circuit to the regulator is opened. Regulator shuts down when the sensing circuit to the regulator does not find continuity. Regulator also shuts down when voltage unbalance exceeds 20% for a specified duration, adjustable by the user.

**Overexcitation Shutdown.** Protects the generator against damage caused by prolonged field forcing.

**Paralleling Mode.** Paralleling for multiple generator setups is standard. Simply add 5 VA current transformers for parallel operation in “droop” or “cross current” compensation.

**Shock.** Withstands up to 20 Gs in each of three (3) perpendicular planes.

**Vibration.** Withstands 0.036 inch peak, 27–52 Hz; 1 G from 5–26 Hz and 5.0 Gs from 53–500 Hz.

**Multiple Use of Current Transformers.** The same current transformers can be used for multiple functions. The voltage regulator does not require separate transformers for paralleling or metering.

**Ease of Use.** All regulator adjustments and LED indicators are located on one side for easy use and adjustment. Push button controls allow adjustment of the various regulator functions.

**External Device Port.** PC or Palm connectivity allows access to enhanced operational features using custom software available from our website or upon request.

**Volts-per-Hertz Operation.** Protects the generator during underspeed operation and aids the prime mover during 100% block load pickup. Adjustable transition between flat regulation and volts-per-hertz ramp adjustable from 40 to 65 Hz. Provides selectable slope of 1 to 3 times PU volts/hertz.

**Accessory Input.**  $\pm 1$  VDC creates a  $\pm 10\%$  adjustment for AVR, FCR, and VAR.  $\pm 1$  VDC creates a  $\pm 0.1$  PF adjustment in the PF mode (adjusts only the active regulation mode).

**EMI Suppression.** Internal electromagnetic interference filter meets MIL-STD-461C, Part 9. for radiated and conducted emissions susceptibility when mounted in the MAGNAMAX<sup>DVR®</sup> generator connection box.

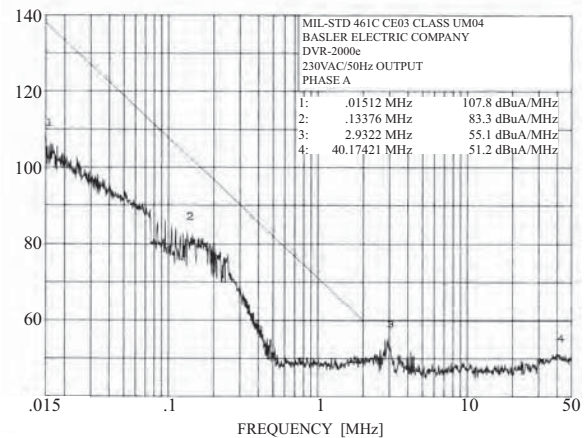

Marathon Electric Mfg. Corp.  
P.O. Box 8003  
Wausau, WI 54402-8003 USA  
Phone: 715.675.3359  
Fax: 715.675.8026  
www.marathonelectric.com

<b>JAY ELECTRIC LIMITED</b>	
<input checked="" type="checkbox"/> Reviewed	
<input type="checkbox"/> Reviewed as noted	
<input type="checkbox"/> Resubmit	
DATE	REVIEWED BY
Feb. 25, 2015	Gary R Beer

GPN023 05-02/2.5M  
Printed in the USA

## MICROPROCESSOR ENGINE/GENERATOR CONTROLLER

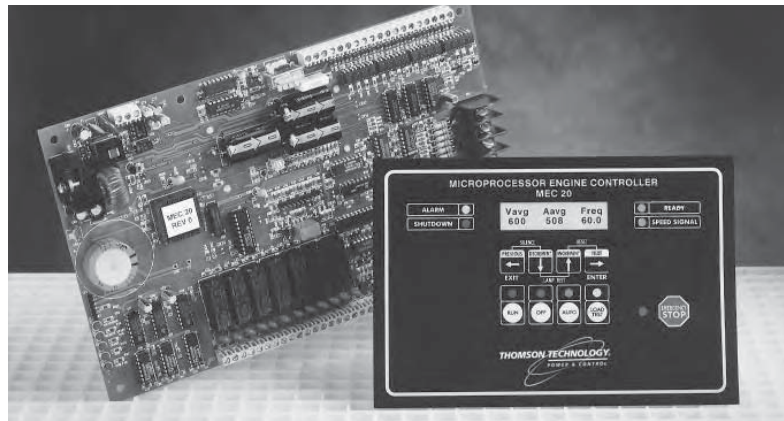

- Microprocessor-based circuitry provides ultimate reliability and versatility
- Standard features meet or exceed requirements as defined by NFPA 110 Level 1 and CSA C282
- Backlit LCD display screen with alpha-numeric readout for display and programming
- Digital 3-phase voltage, 3-phase current, KVA and frequency metering for generator output
- Up to 28 alarm/shutdown fault circuits utilizing analog and digital inputs
- Standard RS422 remote communication serial port
- Alarm/shutdown indications are displayed in plain English language
- Optional expansion output module for individual fault output contacts
- Password protected programming levels
- Self diagnostic features continuously verify processing, I/O and memory circuits
- Superior EMI/RFI noise immunity and surge performance features as per IEEE C62.41
- Certified to UL #508 and CSA 22.2 #14 Industrial Control Equipment Standards

<b>JAY ELECTRIC LIMITED</b>	
<input checked="" type="checkbox"/>	Reviewed
<input type="checkbox"/>	Reviewed as noted
<input type="checkbox"/>	Resubmit
DATE	REVIEWED BY
Feb. 25, 2015	<i>Gary R Beer</i>

### GENERAL DESCRIPTION

The Thomson Technology **MEC 20 Microprocessor-based Engine/Generator Controller** utilizes the latest advancements in microprocessor technology, printed circuit board assembly techniques and software development. This is the eighth generation of engine controllers from Thomson Technology, and reflects over 25 years of engine controller design experience, including a decade utilizing microprocessors. The result is an automatic engine/generator controller of superior design, providing a comprehensive array of operational, protection and display features. All functions of the **MEC 20** are fully configurable from the front panel keypad, and are password protected. The LCD display screen prompts are in plain English, providing a user-friendly operator interface with many display options available. The microprocessor design provides high accuracy for all voltage monitoring, current monitoring and timing functions as well as providing many standard features which are commonly available only as expensive add-on optional features on competitors' products.

## STANDARD FEATURES ▲

- **Alpha-Numeric Readout:** Display and programming
- **Digital AC Metering:** 3 phase voltage (phase to phase and phase to neutral)▲, 3 phase current, KVA, frequency
- **Digital Engine Gauge Display:** Oil pressure, Engine temperature, Battery Voltage, Hourmeter, Tachometer
- **28 Standard Fault Circuits:**

Shutdowns	Alarms	
• Over Crank	• Under Frequency	• Low Oil Pressure
• Under Voltage	• Over Frequency	• Low Fuel Level ▲
• Over Voltage	• Over Current	• Switch Not in <i>Auto</i>
• High Engine Temperature ▲ ▲	• Weak Battery	• Digital Faults #5-#12 ▲
• Low Oil Pressure ▲ ▲ ▲	• Low Battery Voltage	(User programmed) ▲
• Over Speed ▲	• High Battery Voltage	
• Loss of Speed Signal	• Battery Charger Fail ▲	
• Emergency Stop	• Low Engine Temperature	
	• High Engine Temperature	

- **Timers:** Engine Start, Cooldown, Oil Bypass, Over Crank, Cycle Crank
- **Control Switches:** Run/Off/Auto/Load Test, Horn Silence, Lamp Test, Fault Reset
- **Emergency Stop:** Faceplate mounted push-button and provision for remote contact input
- **LCD Display Menus:** AC metering, timer countdown functions, alarm/shutdown indication, engine parameters
- **LED Indicators:** Switch position (run, off, auto, load test), Common alarm, Common shutdown, Ready, Speed signal, Emergency stop
- **AMF (Auto Mains Failure):** Control outputs and timers to control external transfer mechanism
- **Diagnostic LED Indicators:** Watchdog (CPU running), run output energized, crank output energized, remote start signal initiated, common fail output energized
- **Audible Alarm Horn:** Programmable continuous or auto silence feature
- **Run & Crank Output Contacts:** (10A/240VAC, 8A/24Vdc, Form A)
- **Common Fail Output Contact:** (10A/240VAC, 8A/24Vdc, Form C)
- **4 Programmable Output Contacts:** (10A/240VAC, 8A/24Vdc, Form C): User configured function (refer to programming functions available)
- **Provision for Remote Contact Inputs:** Emergency Stop, Remote Reset
- **Engine Senders:** Oil pressure (1/8" NPT), Temperature (1/4" NPT) supplied loose for engine mounting
- **COM** MEC 20 remote communication port (RS422). Can be used in conjunction with external TT Communication Interface Module (CIM module not included).\*

▲ Standard features meet or exceed requirements as defined by NFPA 110 Level 1 & CSA C282.

▲ Requires customer-supplied sensing contact.

▲ For CSA C282 applications, Battery Charger Input Fail alarm is reconfigurable as Low Coolant Level Shutdown.

▲ Generator supply must utilize a solidly grounded neutral system for standard panel connections.

▲ High Engine Temperature and Low Oil Pressure shutdowns are factory programmed to utilize both digital contact and analog sender inputs.

**NOTE:** Customer to supply and install engine-mounted crank pilot relay, magnetic pickup and current transformers.

## OPTIONAL FEATURES

- **CIM** Communication Interface Module with internal 14.4Kbaud modem, RS232/422/485 ports and Modbus™ protocol c/w 6' communication cable. One CIM module provides communication interface for up to ten MEC 20 controllers with COM per system.\*
- **EAP 110** Remote annunciator with data communication link. 20 light annunciator for NFPA 110 (Level 1) & CSA282-00 faults\*
- **EXP** 16 point relay expansion module for individual fault output contacts on MEC 20. Specify number of expansion modules required (one module required for standard C282 or NFPA 110<sup>1</sup>, two modules required for standard and optional fault circuits). Relay contacts are configurable (normally open or closed) and are rated 0.5A 120VAC, 1.0A 30Vdc resistive (maximum)
- **MEC-O&M** Additional Product Manual (one manual is included with each unit shipped)
- **PRG** Custom programming of features (provides up to 6 custom fault labels)
- **VFD** Vacuum fluorescent display for extended low temperature operation (-40°C)

<b>JAY ELECTRIC LIMITED</b>	
<input checked="" type="checkbox"/> Reviewed <input type="checkbox"/> Reviewed as noted <input type="checkbox"/> Resubmit	
DATE	REVIEWED BY
Feb. 25, 2015	Gary R Beer

\* (Refer to separate literature for additional information)

<sup>1</sup> C282 or NFPA 110 standard faults exclude analog faults over/under voltage, over/under frequency, overcurrent, spare digital fault inputs #5 - #12 and programmable output #6

## Model EAP 110

# GENERATOR SET ANNUNCIATOR

### JAY ELECTRIC LIMITED

- Reviewed
- Reviewed as noted
- Resubmit

DATE	REVIEWED BY
Feb. 25, 2015	Gary R Beer



- 20 Light annunciator meets or exceeds requirements of NFPA 110, NFPA 99 & CSA 282-00 building code standards for Emergency Standby Generator systems
- RS 422 Data Communication capability saves installation time & reduces costs
- Programmable annunciation & labeling allows excellent flexibility for different applications
- Automatic “ringback” & flashing annunciator lights provides excellent status indication of existing & incoming fault conditions
- 4 fault annunciation circuits can be activated from external hardwired contacts for added system capability
- Multiple EAP 110 Annunciators can be easily interconnected to provide up to 40 remote annunciation lights from a single MEC 20 engine controller

## DESCRIPTION

The **EAP 110** annunciator is designed for remote fault annunciation of emergency standby generator sets utilizing **Thomson Technology MEC 2 & MEC 20** Engine Controllers. The advanced design uses a RS 422 communication data link to provide the control & monitoring signals between the engine controller and remote annunciator. The communication link allows a simple, cost effective system installation at any building site. Up to 20 individual fault conditions are remotely monitored utilizing both visual LED lights & audible alarm annunciation. Lamp test and alarm horn silence pushbuttons are provided. Each fault is individually programmable for audible horn operation and alarm labels are field configurable. Operation logic includes a

“auto-ringback” feature to annunciate subsequent alarm conditions. For applications requiring additional alarm annunciation from remote sensing contacts, the **EAP 110** can accept up to 4 hardwired contact inputs dependant upon the alarm configuration. The **EAP 110** is DC powered typically from a 12 or 24V engine starting battery. Two **EAP 110** annunciators can be interconnected together via the communication link to allow up to 40 remote annunciator points from a single MEC 20 engine controller (consult Thomson Technology for further details). The standard features of the **EAP 110** meet and exceed all requirements of NFPA 110, NFPA 99 & CSA 282-00 building code standards for Emergency Standby Generator systems.

## SPECIFICATIONS

<b>SUPPLY VOLTAGE</b>	12V or 24V nominal ( $\pm 20\%$ ), negative ground
<b>SUPPLY CURRENT</b>	100 ma (maximum), ( $\pm 20\%$ )
<b>COMMUNICATION PORT</b>	RS 422, 4.8 Kbaud, Thomson Technology T-Net Protocol to MEC2/MEC20 8 conductor #22 AWG (min.) Shielded/Twisted cable (1000 ft Max.), Plug-in RJ45 Connector
<b>DIGITAL CONTACT INPUT</b>	Close to DC Negative
<b>TEMPERATURE RANGE</b>	-40° C TO + 50° C
<b>ENVIRONMENTAL</b>	Faceplate NEMA 12, Rear Enclosure NEMA 1
<b>DIMENSIONS</b>	6.0" W x 6.0" H x 3.0" D
Flush mount adapter option	(7.0" W x 7.0" H)
<b>MOUNTING</b>	Surface Mount (Standard), Flush-mount (Optional) Rear Enclosure conduit box c/w Qty. 8 1/2" knockouts

## ORDERING INFORMATION

The EAP 110 may be ordered separately or in conjunction with the unit mount control panels or engine controllers. When ordering for use with existing MEC 2/MEC 20 engine controller applications in the field, contact Thomson Technology for additional information regarding software/hardware compatibility.

The EAP 110 is supplied from the factory with standard alarm labeling for MEC 2\* or MEC 20\* engine controllers which are applied to meet NFPA 110 Level 1/NFPA 99 or CSA 282 alarm requirements. The standard EAP 110 can be labeled and programmed for alternate alarm configurations (consult Thomson Technology for further information). When specified, the optional flush mount adapter plate is supplied loose with the standard Annunciator for field installation.

### EXAMPLE:

**EAP 110 - S**

BASIC MODEL \_\_\_\_\_

MOUNTING \_\_\_\_\_

S = SURFACE (Standard)  
F = FLUSH (Optional)

JAY ELECTRIC LIMITED	
<input checked="" type="checkbox"/> Reviewed	<input type="checkbox"/> Reviewed as noted
<input type="checkbox"/> Resubmit	
DATE	REVIEWED BY
Feb. 25, 2015	Gary R Beer

\*Note: For MEC 2 / MEC 20 details refer to separate brochures.

## EXTERNAL CONNECTIONS

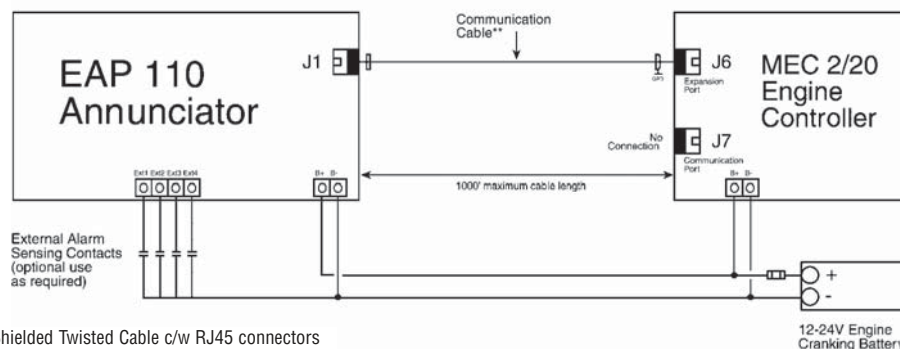

\*\* 8 conductor Shielded Twisted Cable c/w RJ45 connectors

**NOTE:** Specifications subject to change without notice.  
CL057 Rev 1 04/06/01

# T5

## 400A / 600A, 600VAC Δ

### Electronic and Thermal-Magnetic

T5



T5

**Dimensions** 3P Fixed Version 8.07H x 5.51W x 4.07D  
**Weight** 8.55 (lbs)

JAY ELECTRIC LIMITED	
<input type="checkbox"/> Reviewed	
<input checked="" type="checkbox"/> Reviewed as noted	
<input type="checkbox"/> Resubmit	
DATE	REVIEWED BY
Feb. 25, 2015	Gary R Beer

Breakers unit mounted & line side wired at factory. Provide load side lugs as per Jay BOM.

#### General

The T5 breaker is a 400/600 amp frame with either a microprocessor based over current protective trip system or a thermal magnetic trip unit. <sup>(3)</sup>

#### Standards

The UL489/CSA C22.2 No. 5 version of T5 also carries an IEC-60947-2 rating. →

#### Versions

To meet all application requirements, the T5 is available in the following versions:

- T = Thermal-magnetic
- B = Selectable & adjustable LI or LS
- C = Adjustable LSI
- E = Adjustable LSIG
- D = Molded Case Switch
- E5 = Electronic instantaneous only (MCP)

#### Trip Functions

These trip functions are available:

- L = Long time
- S = Short time
- I = Instantaneous
- G = Ground fault

#### Performance Levels

Each version is also available in different maximum fault interrupting levels:

- N = Normal
- S = Standard
- H = High
- L = Extra high
- V = Very high

#### Number of Poles <sup>(4)</sup>

The T5 is available as a 2, 3 and 4 pole breaker. The 2 and 3 pole versions have the same dimensions.

#### Reverse Feeding

All versions of the T5 family are suitable for reverse feed application.

#### UL489 / CSA C22.2 Interrupting Capacity (kA RMS)

Voltage	N	S	H	L	V
240VAC	65	100	150	200	200
480VAC	25	35	65	100	150
600VAC	18	25	35	65	100
500VDC <sup>(1)</sup>	25	35	50	65	100
600VDC <sup>(2)</sup>	16	25	35	50	65

#### IEC 60947-2 Interrupting Capacity (kA RMS)

Voltage	N	S	H	L	V
230VAC	70	85	100	200	200
415VAC	36	50	70	120	200
440VAC	30	40	65	100	180
500VAC	25	30	50	85	150
690VAC	20	25	40	70	80
750VDC <sup>(2)</sup>	16	25	36	50	70

(1) 2 poles in series.

(2) 3 poles in series.

(3) T5 600A not available with thermal magnetic trip unit.

(4) 2 pole available in N version only. 4 pole available in N and H version only.

**T5**  
**400A / 600A**  
**Electronic (AC Only)**

**T5-400A Frame, Electronic Trip Unit (AC Only) 160-400A Adjustable Range**

Breaker	IC at 600VAC	Trip Unit	2-Pole, 600VAC Part Number	List Price	3-Pole, 600VAC Part Number	List Price	4-Pole, 600VAC Part Number	List Price
→ T5N	18kA	PR221 LS/I PR222 LSI PR222 LSIG	T5N400BW-2 T5N400CW-2 T5N400EW-2		→ T5N400BW T5N400CW T5N400EW		T5N400BW-4 T5N400CW-4 T5N400EW-4	
T5S	25kA	PR221 LS/I PR222 LSI PR222 LSIG			T5S400BW T5S400CW T5S400EW			
T5H	35kA	PR221 LS/I PR222 LSI PR222 LSIG			T5H400BW T5H400CW T5H400EW		T5H400BW-4 T5H400CW-4 T5H400EW-4	
T5L	65kA	PR221 LS/I PR222 LSI PR222 LSIG			T5L400BW T5L400CW T5L400EW			
T5V	100kA	PR221 LS/I PR222 LSI PR222 LSIG			T5V400BW T5V400CW T5V400EW			

<b>JAY ELECTRIC LIMITED</b>	
<input checked="" type="checkbox"/> Reviewed <input type="checkbox"/> Reviewed as noted <input type="checkbox"/> Resubmit	
DATE	REVIEWED BY
Feb. 25, 2015	<i>Gary R Beer</i>

**Accessories**  
**Mechanical**  
**T1-T6**

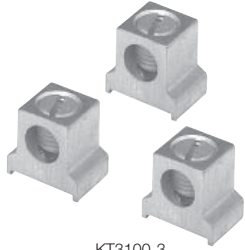

KT3100-3

**Standard Cable Terminal**

Frame	Wire Size	Part Number (set of 3)	List Price	Part Number (set of 4)	List Price
T5	300A (250 kcmil - 500 kcmil)	KT5300-3		KT5300-4	
T5 <sup>(1)</sup>	400A (2x 3/0 - 2x 250 kcmil)	KT5400-3		KT5400-4	
T5	600A (2x 3/0 - 2x 500 kcmil)	KT5600-3		—	

**Note:** for power control tap lugs, please consult your local ABB office

<b>JAY ELECTRIC LIMITED</b>	
<input checked="" type="checkbox"/> Reviewed <input type="checkbox"/> Reviewed as noted <input type="checkbox"/> Resubmit	
DATE	REVIEWED BY
Feb. 25, 2015	<i>Gary R Beer</i>

(1) Comes standard with high profile terminal covers.

# Accessories

## Electrical T1-T6

Acc.

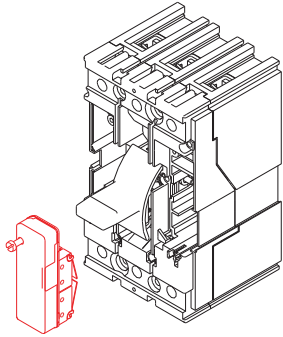

T1 with K3TAS



KT3S3AS

### Auxiliary Contacts - AUX <sup>(1)</sup>

Auxiliary contacts are for indication of the circuit breaker open-closed. Bell alarm contacts (BA) can be used to indicate circuit breaker tripped.

Frame Size	Factory Installation		Field Installation	
	Part Number Suffix	List Price Adder	Part Number	List Price
T4-T5-T6	1 AUX "C" + 1 BA "C" 250VAC/DC	A	KT6AS	
	2 AUX "C" 400VAC	A2	KT6AS2	
	3 AUX "C" + 1 BA "C" 250VAC/DC	A3	KT6AS3	
	3 AUX "C" + 1 BA "C" 24VDC	A3L	KT6AS3L	

### Auxiliary Contact Connector (Required for Ts3) <sup>(4)</sup>

Ts3	Fixed Plug-In /Drawout	Not required for factory install Not required for factory installed	C-AB KTs3C-ABP

<b>JAY ELECTRIC LIMITED</b>	
<input checked="" type="checkbox"/> Reviewed <input type="checkbox"/> Reviewed as noted <input type="checkbox"/> Resubmit	
DATE	REVIEWED BY
Feb. 25, 2015	Gary R Beer

(1) Add suffix to circuit breaker part number. See p.4 for more details.  
 (2) Not compatible for T2 with PR221DS trip unit.  
 (3) For installation on T2 with PR221DS electronic trip unit  
 (4) Must be ordered separately for field installation.

- Reviewed
- Reviewed as noted
- Resubmit

DATE: Feb. 25, 2015  
 REVIEWED BY: Gary R Beer

# Trip curves for power distribution

## Circuit breakers with electronic trip units

### T2 100 – PR221DS-LS

L-I Functions

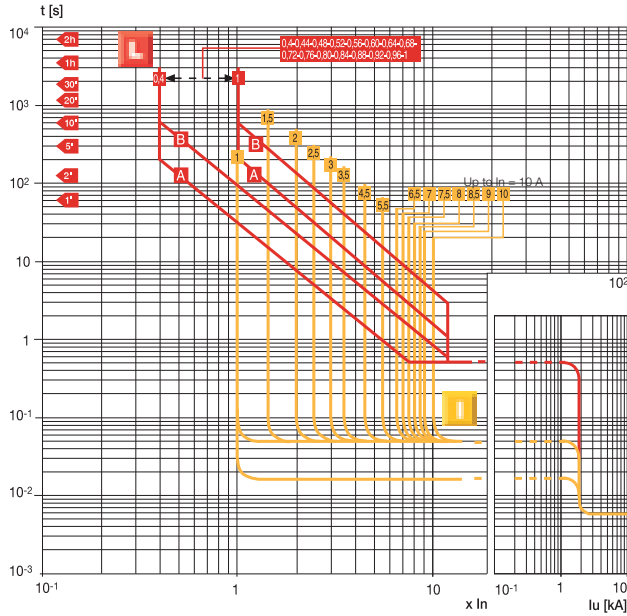

### T2 100 – PR221DS-LS

L-S Functions

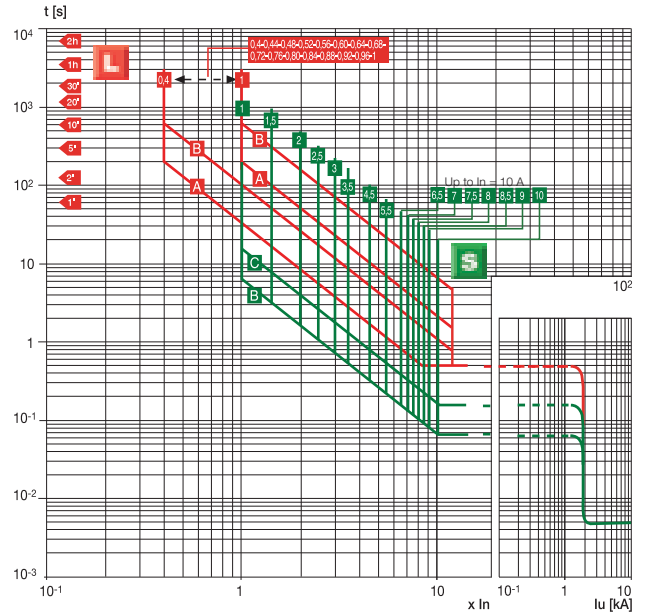

### T2 100 – PR221DS-I

I Function

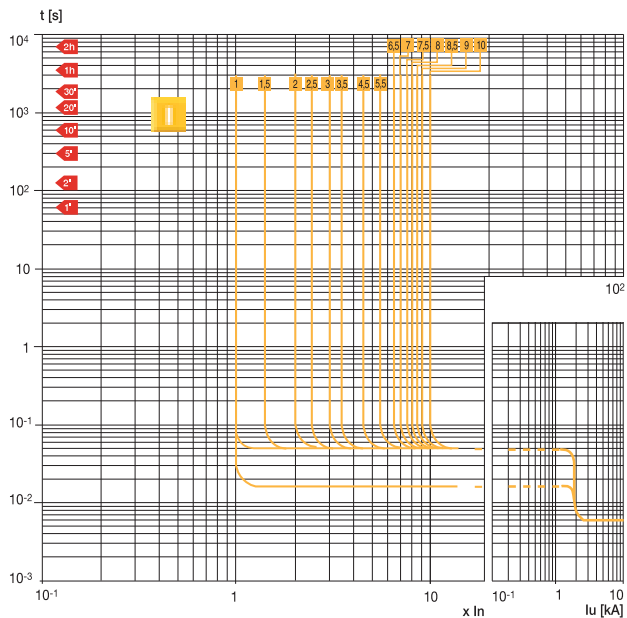

### T4 250 / T5 400/600 – PR221DS

L-I Functions

Note: For T5 In = 600 A ⇒ I<sub>3</sub>max = 9.5 x In

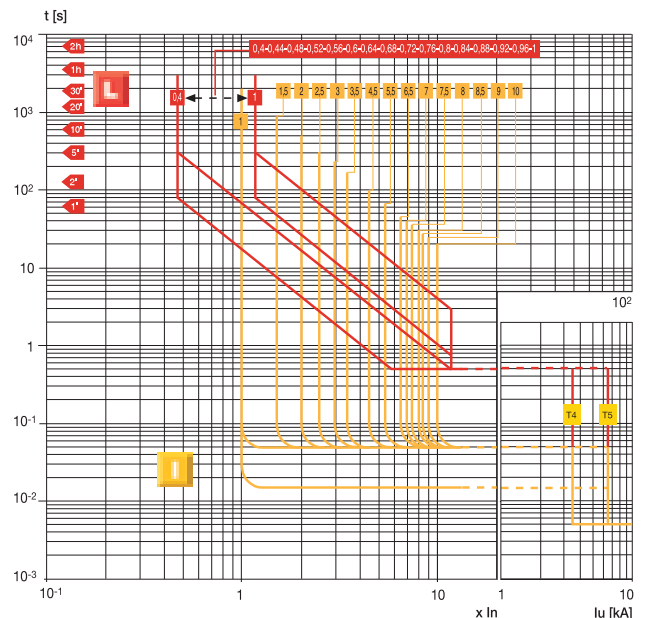

## Silencers Model SM4P Un-Insulated Hospital Plus 40-50 dBA

### Applications and Performance

Model SM4P silencers are recommended for use in areas where the surrounding noise level is extremely low. These silencers achieve a ultra high noise reduction by utilizing a multi chamber design that incorporates a series of non-resonant tube arrangements that allow the gases to flow from one chamber to another. This creates a reversal of flow and develops a predictable amount of back pressure.

### Selecting The Right Silencer

In selecting a proper size silencer for a given application, consideration must be given to the amount of back pressure that will be imposed by the silencer. Other considerations in the selection of silencers are exhaust velocity and the amount of pipe that will be used in conjunction with the exhaust system. Custom designs are available. Optional features include mounting brackets, stainless steel and high heat black or silver paint.

ATTENUATION CURVE

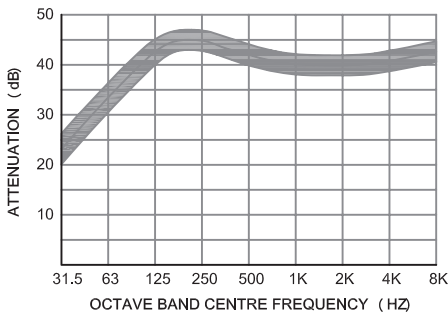

PRESSURE DROP

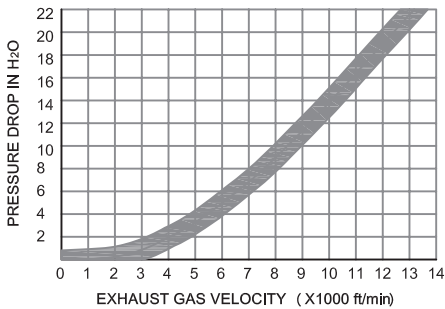

Model	A		B		C		D		N / min		N / max		O		P		Weight.	
	in	(mm)	in	(mm)	in	(mm)	in	(mm)	in	(mm)	in	(mm)	in	(mm)	in	(mm)	Lb	(Kg)
SM4P-6	26	(660)	88	(2235)	6	(152)	80	(2032)	11	(279)	19	(483)	17	(432)	84	(2134)	307	(140)

All sizes and measurements are in inches (mm) and pounds (kg)

<b>JAY ELECTRIC LIMITED</b>	
<input checked="" type="checkbox"/> Reviewed	
<input type="checkbox"/> Reviewed as noted	
<input type="checkbox"/> Resubmit	
DATE	REVIEWED BY
Feb. 25, 2015	Gary R Beer

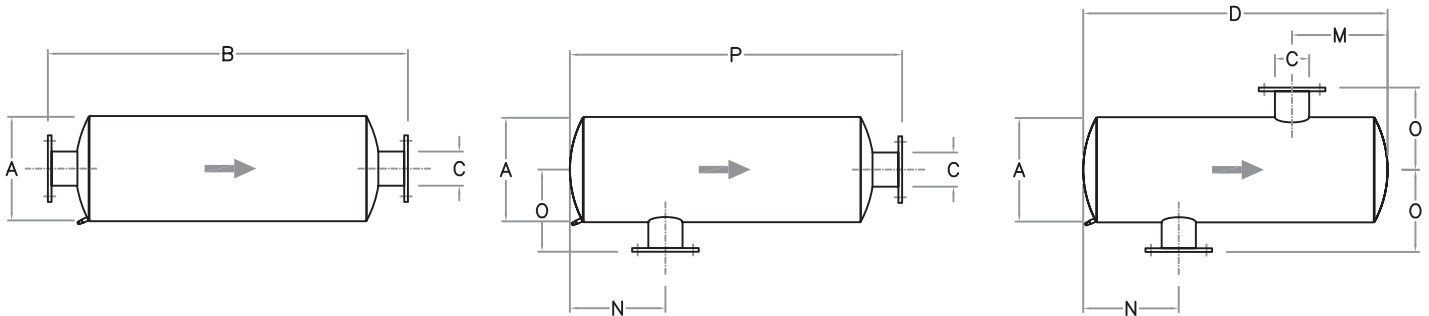

Flange connection conform to ANSI 150lbs.  
Sizes 3/2" and smaller have N.P.T connections  
Contact SMS for "M" dimensions

The silencer may be installed at any angle. When mounting horizontally allow for a 3/8" per foot to provide drainage.

Mounting brackets, side inlet connections, clean out doors and companion flanges are available at additional cost.

The silencer is of an all welded construction and the exterior surfaces are given a coat of high temperature paint.

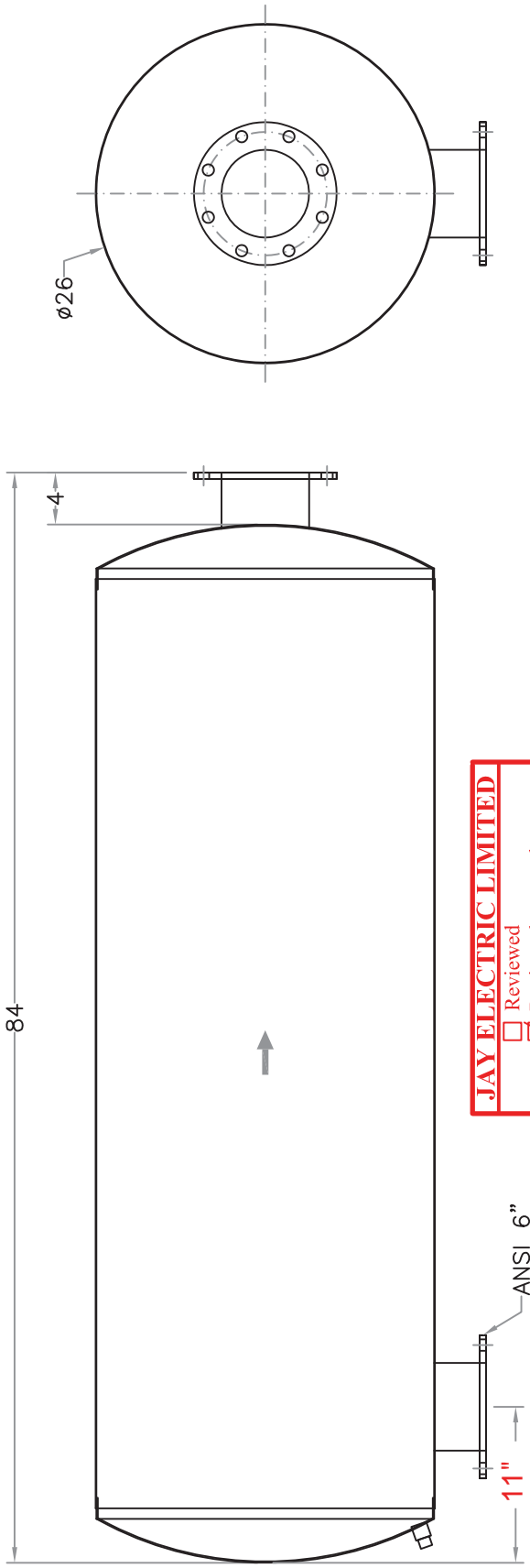

**JAY ELECTRIC LIMITED**

Reviewed  
 Reviewed as noted  
 Resubmit

DATE: Feb. 25, 2015  
 REVIEWED BY: Gary R Beer

Sound Attenuation Curve  
Hospital Plus Grade: 40-50 dBA

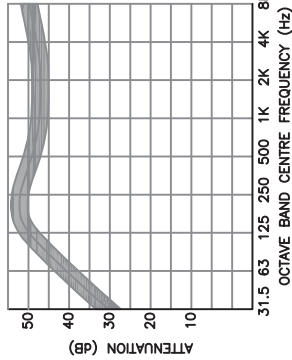

Manufacturer to advise if saddle/cradle support is necessary for silencer to mitigate creepage and deformation. If so, a shop drawing of the saddle/cradle is required.

Standard Specifications

- MATERIAL: MILD STEEL
- UN-INSULATED
- APPROXIMATE WEIGHT: 324 Lb
- DRAIN : 3/8"
- HIGH HEAT BLACK PAINT

Options

- MATERIAL: STAINLESS STEEL
- INSULATED

All dimensions are in inches (") unless otherwise stated

Title		6" HOSPITAL PLUS GRADE SILENCER	
Client		PARAMOUNT POWER SYSTEMS	
Project		-	
Dwg. Nbr	Revision	Plot Scale	NTSC
SM4P-6-SI	A	Format	11x8 1/2"
		Date	27/JUL/11
www.smssilencers.com sales@smssilencers.com Tel: 905-459-1512 Fax: 905-459-3138 153A Rutherford Road South Brampton, ON L6W3N5			
SMS SILENCERS RESERVES THE PROPRIETARY RIGHTS TO THIS DRAWING AND THE DATA SHOWN THEREON AND IS SUBMITTED IN CONFIDENCE ONLY. SAID DRAWING AND/OR DATA ARE NOT TO BE USED OR REPRODUCED FOR ANY PURPOSE WITHOUT WRITTEN CONSENT OF SMS SILENCERS			

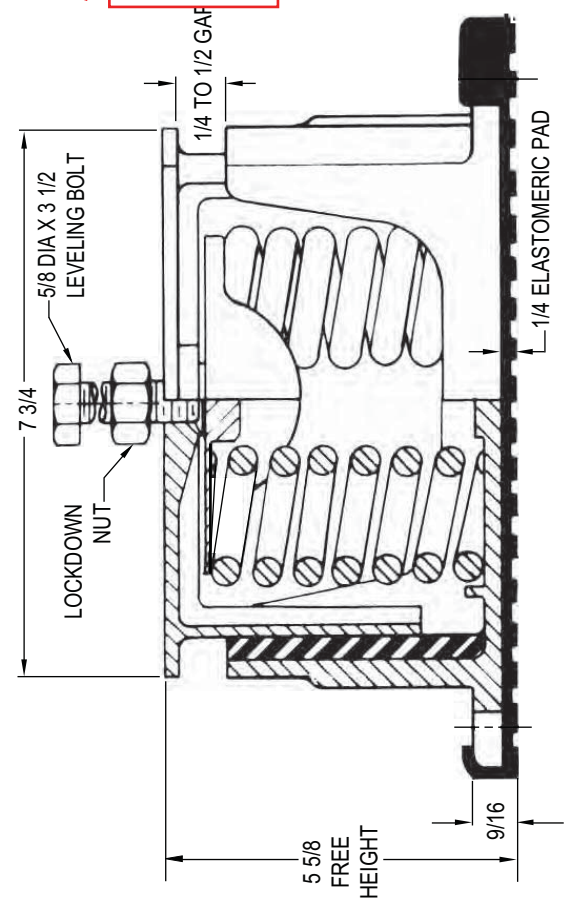
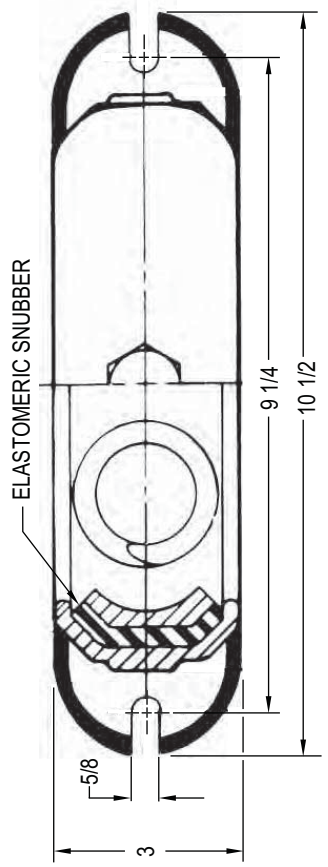

X4

MODEL	MAX LOAD (LBS)	DEFLECTION (IN)	SPRING RATE (LB/IN)	SPRING COLOR CODE
C2E-1D-680	680	1.13	600	RED
C2E-1D-1020	1020	1.02	1000	BLACK
C2E-1D-1350	1350	1.32	1026	DK PURPLE
C2E-1D-1800	1800	1.02	1762	DK GREEN
C2E-1D-2400	2400	0.90	2654	GRAY
C2E-1D-2720	2720	0.77	3516	WHITE
C2E-1D-3570N <sup>1</sup>	3570	0.88	4058	GRAY/RED

**NOTES:**

1. TWO NESTED SPRINGS YIELD THIS LOAD. THE COLOR CODE IS FOR OUTER SPRING/INNER SPRING.

**JAY ELECTRIC LIMITED**  
 Reviewed  
 Reviewed as noted  
 Resubmit  
**DATE** Feb. 25, 2015  
**REVIEWED BY** Gary R Beer

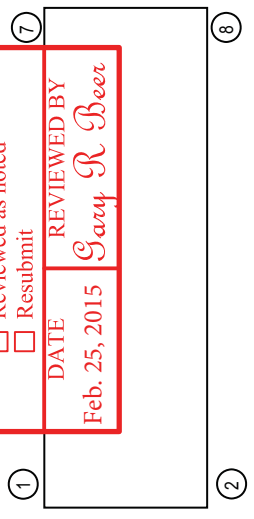

**ISOLATOR SELECTIONS**

LOC 1:	C2E-1D-1800
LOC 2:	C2E-1D-1800
LOC 3:	
LOC 4:	
LOC 5:	
LOC 6:	
LOC 7:	C2E-1D-1800
LOC 8:	C2E-1D-1800

CUSTOMER EQP'T. TAG:

NOTE: MATERIAL SHOWN IS FOR (1) SET.

OTHER MATERIALS, COMPOUNDS, OR FINISHES WITH EQUAL OR SUPERIOR PROPERTIES MAY BE SUBSTITUTED AS THEY BECOME AVAILABLE.

- NOTES:**
- ALL DIMENSIONS ARE IN INCHES. INTERPRET PER ANSI Y-14.
  - FINISH: HOUSINGS CAST IRON- ONE COAT BLACK PAINT, SPRINGS- POWDER COAT, HARDWARE- ZINC ELECTROPLATE.
  - REFER TO DRAWING 2 OF 2 FOR INSTALLATION INSTRUCTIONS.
  - INNER SPRING (WHEN USED) NOT SHOWN.
  - ALL SPRINGS ARE DESIGNED WITH 50% OVER-TRAVEL.

**CERTIFIED FOR:**

JOB NAME: \_\_\_\_\_  
 CUSTOMER: \_\_\_\_\_  
 CUSTOMER PO: \_\_\_\_\_  
 SALES ORDER: \_\_\_\_\_

**SERIES C2E-1D  
 CAST IRON SPRING-FLEX MOUNTINGS  
 WITH EXTERNAL ADJUSTMENT  
 1" NOMINAL DEFLECTION**



THE VMC GROUP  
 The Power of Together™  
 Bloomingdale, NJ 07403  
 Houston, TX, 77041

SCALE: NONE  
 SHEET: 1 OF 2  
 DRAWING NO.:



REVISION

120R-101653 REV: 4

REV. DESCRIPTION DATE BY

**JAY ELECTRIC LIMITED**

Reviewed  
 Reviewed as noted  
 Resubmit

DATE: Feb. 25, 2015  
 REVIEWED BY: Gary R Beer

INSTALLATION INSTRUCTION

- ISOLATORS ARE SHIPPED FULLY ASSEMBLED AND ARE TO BE SPACED AND ARRANGED IN ACCORDANCE WITH INSTALLATION DRAWINGS OR AS OTHERWISE RECOMMENDED.
- SET ISOLATORS ON FLOOR OR SUB-BASE, ENSURING THAT ALL ISOLATOR CENTERLINES MATCH THE EQUIPMENT MOUNTING HOLES. SHIM OR GROUT AS REQUIRED LEVELING ALL ISOLATOR BASE PLATES "E" AT THE SAME ELEVATION (1/4" MAXIMUM DIFFERENCE IN ELEVATION CAN BE TOLERATED). ISOLATOR BASE PLATES MUST REST ON A FLAT SURFACE.
- UNLESS SPECIFIED, MOUNTINGS NEED NOT BE FASTENED TO FLOOR IN ANY WAY. IF REQUIRED, BOLT MOUNTINGS TO FLOOR THROUGH SLOTS "D".
- REMOVE ADJUSTING BOLT "C" WITH NUT "B" FROM TOP HOUSING "A". (DO NOT DISCARD.)
- PLACE MACHINE OR EQUIPMENT ONTO TOP PLATE "A" OF ISOLATOR. THE WEIGHT OF THE MACHINE WILL CAUSE THE UPPER HOUSING OF THE MOUNT TO GO DOWN, POSSIBLY RESTING ON THE LOWER HOUSING.
- ALIGN EQUIPMENT MOUNTING HOLE TO TOP HOUSING TAPPED HOLE.
- TURN NUTS "B" UP ON LEVELING BOLTS SO THAT THEY WILL NOT INTERFERE WITH THE LEVELING PROCEDURE. INSERT BOLTS "C" THROUGH THE HOLES IN MACHINE BASE AND SCREW INTO THE TAPPED HOLE IN THE UPPER HOUSING OF THE MOUNTING BY HAND AS FAR AS THEY WILL GO.
- ADJUST EACH ISOLATOR IN SEQUENCE; SCREW DOWN ONE COMPLETE TURN ON THE ADJUSTING BOLT OF EACH MOUNTING. ADJUST UNTIL 1/4" GAP IS OBTAINED ON ALL MOUNTS.
- TURN NUT ON ADJUSTING BOLT "C" DOWN AGAINST MACHINE LEG AND LOCK IN PLACE WITH WRENCH TO COMPLETE ADJUSTMENTS.
- INSTALLATION IS COMPLETE.

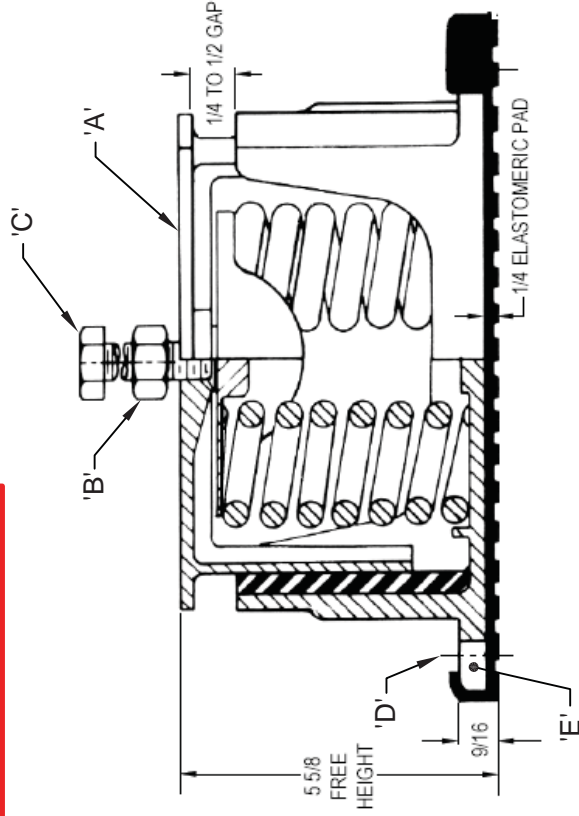

OTHER MATERIALS, COMPOUNDS, OR FINISHES WITH EQUAL OR SUPERIOR PROPERTIES MAY BE SUBSTITUTED AS THEY BECOME AVAILABLE.

**CERTIFIED FOR:**

JOB NAME: \_\_\_\_\_

CUSTOMER : \_\_\_\_\_

CUSTOMER P.O.: \_\_\_\_\_

SALES ORDER: \_\_\_\_\_

**SERIES C2E-1D**  
**CAST IRON SPRING-FLEX MOUNTINGS**  
**WITH EXTERNAL ADJUSTMENT**  
**1" NOMINAL DEFLECTION**



**THE VMC GROUP**  
*The Power of Together*  
 Bloomington, NJ 07403  
 Houston, TX 77041

SCALE :

NONE

SHEET:

2 OF 2

DRAWING NO.:

REVISION

# Small Tank Heaters

**High Impact Plastic**  
**Single Phase**  
**500-2000 Watts**  
**120V & 240V**



View of a Kim Hotstart TPS tank heater. This durable heater is assembled with a built-in thermostat and 4-foot power cord.

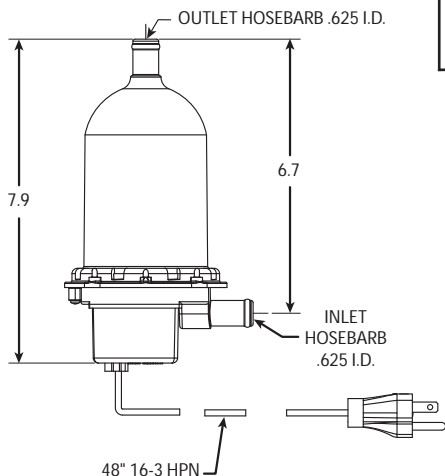
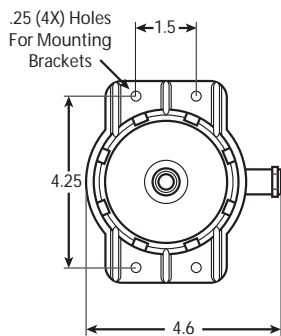

- Molded from Polyphenylene Sulfide (PPS).
- Rust-free, resists corrosion, exceptional tensile strength.
- Vibration and shock tested to extreme limits to guarantee durability.
- Greatly reduced heat loss for more efficient operation.
- Compatible with all chemicals.
- Incoloy element for longer service life.
- Thermostatically controlled.
- All parts are field replaceable — not a throw away heater.
- Compact design requires minimal mounting space.

Ambient Above -20° F	Ambient Below -20° F	Kim Hotstart Model Number	Volts	Phase	Watts	Amps	Thermostat Range	
							On	Off
150 Cubic Inch or Less	150 Cubic Inch or Less	TPS051GT8-000	120	1	500	4.2	80°F	100°F
		TPS051GT10-000	120	1	500	4.2	100°F	120°F
		TPS051GT12-000	120	1	500	4.2	120°F	140°F
		TPS051GT12-A00	120	1	500	4.2	ADJUSTABLE*	
		TPS052GT8-000	240	1	500	2.1	80°F	100°F
		TPS052GT10-000	240	1	500	2.1	100°F	120°F
		TPS052GT12-000	240	1	500	2.1	120°F	140°F
		TPS052GT12-A00	240	1	500	2.1	ADJUSTABLE*	
350 Cubic Inch or Less	200 Cubic Inch or Less	TPS101GT8-000	120	1	1000	8.4	80°F	100°F
		TPS101GT10-000	120	1	1000	8.4	100°F	120°F
		TPS101GT12-000	120	1	1000	8.4	120°F	140°F
		TPS101GT12-A00	120	1	1000	8.4	ADJUSTABLE*	
		TPS102GT8-000	240	1	1000	4.2	80°F	100°F
		TPS102GT10-000	240	1	1000	4.2	100°F	120°F
		TPS102GT12-000	240	1	1000	4.2	120°F	140°F
		TPS102GT12-A00	240	1	1000	4.2	ADJUSTABLE*	
350 — 500 Cubic Inch or Less	200 — 300 Cubic Inch or Less	TPS151GT8-000	120	1	1500	12.5	80°F	100°F
		TPS151GT10-000	120	1	1500	12.5	100°F	120°F
		TPS151GT12-000	120	1	1500	12.5	120°F	140°F
		TPS151GT12-A00	120	1	1500	12.5	ADJUSTABLE*	
		TPS152GT8-000	240	1	1500	6.3	80°F	100°F
		TPS152GT10-000	240	1	1500	6.3	100°F	120°F
		TPS152GT12-000	240	1	1500	6.3	120°F	140°F
		TPS152GT12-A00	240	1	1500	6.3	ADJUSTABLE*	
500 — 700 Cubic Inch or Less	300 — 400 Cubic Inch or Less	TPS181GT8-000	120	1	1800	15	80°F	100°F
		TPS181GT10-000	120	1	1800	15	100°F	120°F
		TPS181GT12-000	120	1	1800	15	120°F	140°F
		TPS181GT12-A00	120	1	1800	15	ADJUSTABLE*	
		TPS202GT8-000	240	1	2000	8.3	80°F	100°F
		<b>TPS202GT10-000</b>	240	1	2000	8.3	100°F	120°F
		TPS202GT12-000	240	1	2000	8.3	120°F	140°F
		TPS202GT12-A00	240	1	2000	8.3	ADJUSTABLE*	

Qty: 1

\*Off temperature – adjustable 90-130°F (On differential – 20° F)

**JAY ELECTRIC LIMITED**

Reviewed  
 Reviewed as noted  
 Resubmit

DATE: Feb. 25, 2015  
 REVIEWED BY: Gary R Beer

Provide 208 volt heater

## Type DS - DSP

For floating and charging standby batteries - diesel starting.

<b>JAY ELECTRIC LIMITED</b>	
<input checked="" type="checkbox"/> Reviewed <input type="checkbox"/> Reviewed as noted <input type="checkbox"/> Resubmit	
DATE	REVIEWED BY
Feb. 25, 2015	<i>Gary R Beer</i>



DSP24- 10 (top), TA24/7CVET (bottom) shown

The "DS" Model - automatic battery charger available in 12 volt or 24 volt is ideal for keeping a lead acid battery up to full charge at all times. Designed with reliability and battery protection against overcharging, utilizing the HI- LO charging method. In operation the charging commences at HI- rate, automatically reducing to float-rate of 2.17 V.P.C. Engine cranking will automatically place the charger back in the HI- rate mode.

### STANDARD FEATURES:

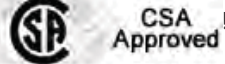
- |   |  |
|---|--|
| <ul style="list-style-type: none"> <li>■ Input: 120 VAC, 60 Hz, 1PH!</li> <li>■ Ammeter 5%(accuracy)!</li> <li>■ Circuit breaker - D.C. auto reset!</li> <li>■ Main - on- off switch!</li> <li>■ Two rate, C/W float/equalize switch.!</li> <li>■ Full- wave bridge silicon rectifier.!</li> <li>■ Temperature compensated transistorized voltage sensing circuit.!</li> <li>■ A.C. On pilot lamp amber!</li> </ul> | <ul style="list-style-type: none"> <li>■ Equalize pilot lamp red!</li> <li>■ Transformer double wound with A.C. input adjustable taps!</li> <li>■ Float rate adjustable, factory preset 12 volt battery (13 volt at 150 M.A.) - 24 volts battery - (26 volts at 150 M.A.)!</li> <li>■ Transformer double wound with A.C. input adjustable taps!</li> </ul> <div style="text-align: center;">  </div> |
|---|--|

### OPTIONAL FEATURES:

- |  |   |
|--|---|
| <ul style="list-style-type: none"> <li>■ Manual equalize timer - (replaces float/equalize switch) available - 12 hour Add suffix "ET12"</li> <li>■ Voltmeter 0- 20 volts or 0- 50 volts, 5%accuracy.</li> <li>■ A.C. input breaker protection</li> </ul> | <ul style="list-style-type: none"> <li>■ LO or HI battery voltage alarm - only one available.</li> <li>■ Low battery voltage alarm - form "C" - contacts - Add suffix "LV"</li> <li>■ High battery voltage alarm - form "C" - contacts Add suffix "HV"</li> </ul> |
|--|---|

Maximum Ratings:	Input: 120 volt 60 Hz	Output: 12 or 24 volt	12 amperes DC
Dimensions inch (mm)		Height: 9 1/2" (242)	Width: 16" (407)
Depth: 9" (229)			
Note: Cabinet dimensions can vary depending on options specified. Can be wall mounted			

### Type DS Models

	Volts DC	Amp DC	Volt AC	Amp AC
DS- 12	12	12	120	3
DS- 24	24	12	120	4.5

### Type DSP Models

	Volts DC	Amp DC	Volt AC	Amp AC
DSP- 12	12	12	120	3
DSP- 24	24	12	120	4.5

ITEM NO.	PART NUMBER	DESCRIPTION	QTY.
1	DSP 24-10	Vulcan Battery Charger, Output: 24VDC, 10A -Input: 120VAC, 3.5A	1
2	316-005		4
3	DSP-CHGR-BRKT-1	Battery Charger Bracket-Bottom	2
4	DSP-CHGR-BRKT-2	Battery Charger Bracket-Top	1
5	Regular FW 0.3125		12
6	Regular LW 0.25		8
7	Regular LW 0.3125		10
8	Regular LW 0.25		4
9	HNUT 0.3125-18-D-N		10
10	HNUT 0.2500-20-D-N		4
11	HBOLT 0.3125-18x1x0.875-N		2
12	HBOLT 0.2500-20x0.75x0.75-N		4

**JAY ELECTRIC LIMITED**  
 Reviewed  
 Reviewed as noted  
 Resubmit

**DATE**      **REVIEWED BY**  
Feb. 25, 2015      *Sandy R Beer*

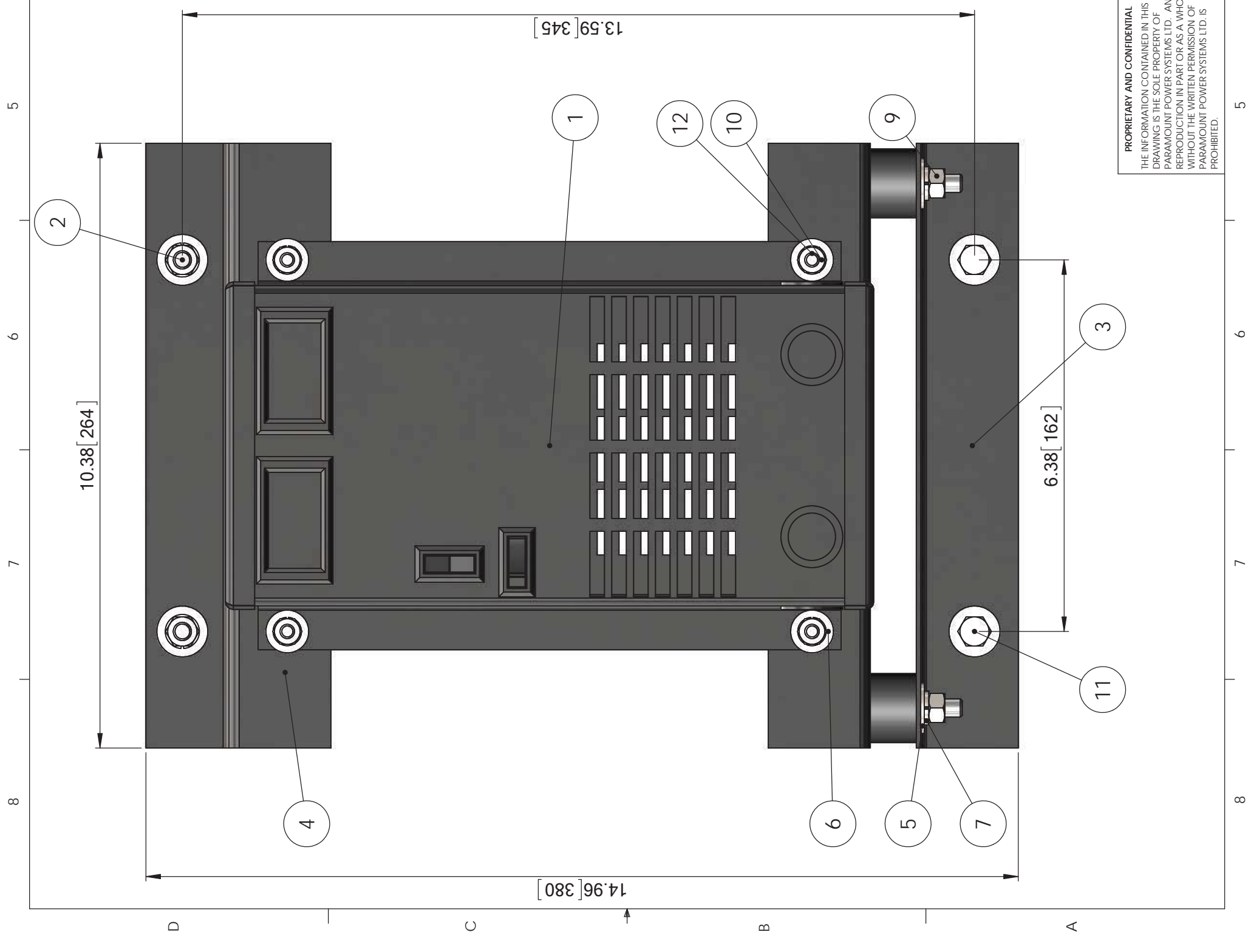
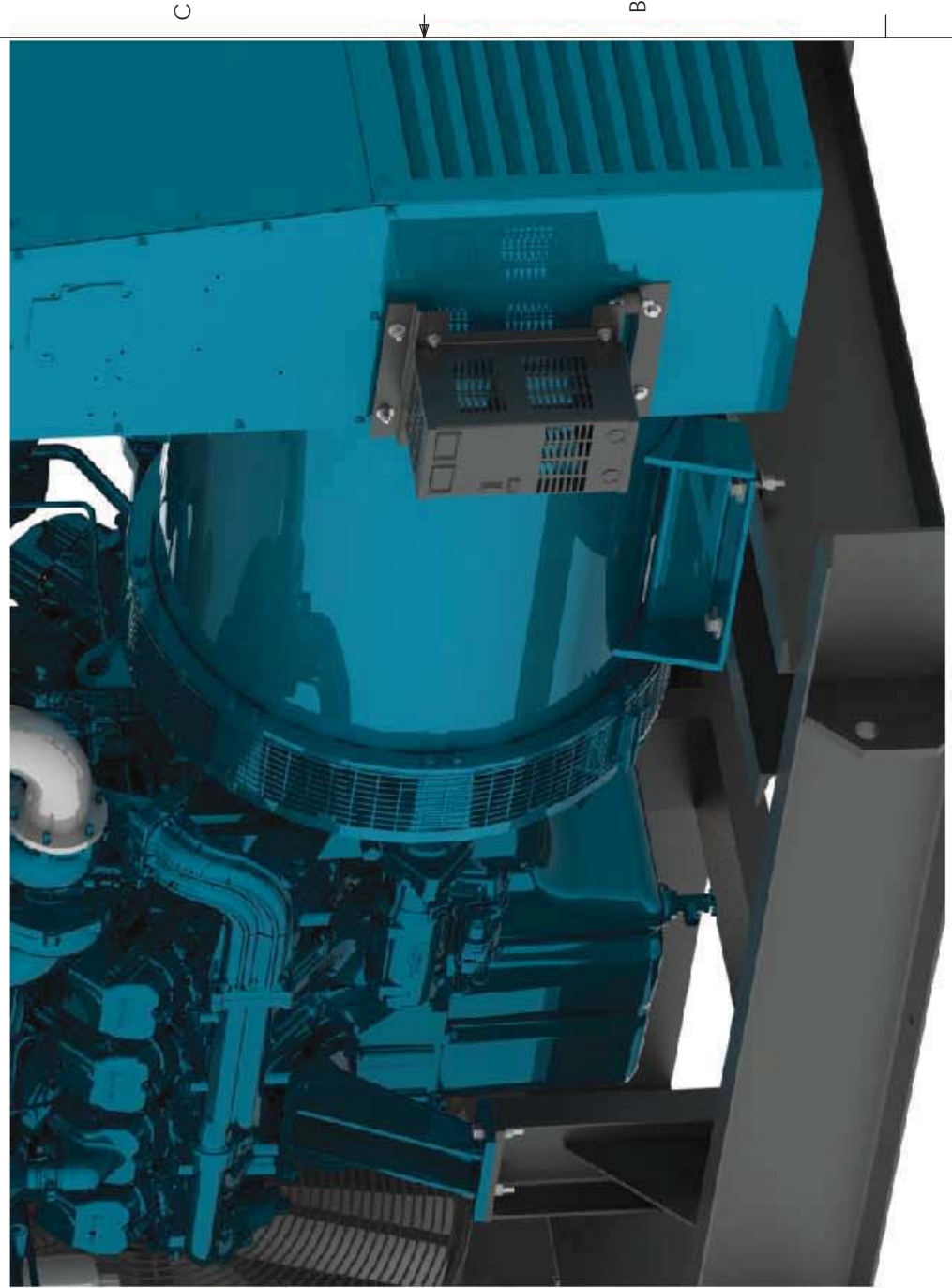

UNLESS OTHERWISE SPECIFIED: DIMENSIONS ARE IN INCHES & (MILLIMETERS)	NAME	DATE	TITLE:
TOLERANCES: FRACTIONAL ± ANGULAR: MACH ± BEND ± TWO PLACE DECIMAL ± 0.13° THREE PLACE DECIMAL ±	L.C.	08/02/15	VULCAN DSP CHARGER ASSEMBLY KIT
INTERPRET GEOMETRIC TOLERANCING PER:	L.C.	08/02/15	
MATERIAL			
FINISH			
USED ON			
APPLICATION			
DO NOT SCALE DRAWING			

DRAWN	NAME	DATE	TITLE:
CHECKED	L.C.	08/02/15	VULCAN DSP CHARGER ASSEMBLY KIT
ENG APPR.			
MFG APPR.			
O.A.			
COMMENTS:			

SCALE: 1:5	WEIGHT:	SHEET 1 OF 1
------------	---------	--------------

**PARAMOUNT POWER SYSTEMS LTD.**  
MISSISSAUGA ONTARIO CANADA

SIZE DWG. NO. REV  
**B** DSP-CHGR-KIT NEW



# BATTERY LINE SPECIFICATIONS

**JAY ELECTRIC LIMITED**

- Reviewed
- Reviewed as noted
- Resubmit

DATE	REVIEWED BY
Feb. 25, 2015	Gary R Beer

GROUP NUMBER	PART NO. (WET)	PERFORMANCE LEVEL			SUGG. WARR.	QUARTS OF ACID	APPROXIMATE WEIGHT		MAXIMUM OVERALL DIMENSIONS (in inches and mm)			COLOR CODE COVER/CASE	FOOT NOTES			
		CCA @ 0°F	RESERVE CAPACITY	MCA @ 32°F			WET	DRY	L	W	H					
<b>12-VOLT HEAVY-DUTY COMMERCIAL SERVICE</b>																
<b>4D</b>	<b>804DMM</b>	<b>925</b>	<b>240</b>	<b>1150</b>	<b>30</b>	<b>—</b>	<b>97</b>	<b>—</b>	<b>20%</b>	<b>527</b>	<b>8½</b>	<b>216</b>	<b>10</b>	<b>254</b>	<b>BB</b>	<b>★H</b>
	<del>004DMM</del>	<del>1010</del>	<del>200</del>	<del>1235</del>	<del>30</del>	<del>16</del>	<del>90%</del>	<del>58</del>							<b>BB</b>	<b>★H</b>

QTY:2

Effective June 1, 2005

Supersedes all previous information. Subject to change without notice.

UL Recognized Component

QUALITY SYSTEM  
CERTIFIED TO  
**ISO 9001**  
**ISO/TS 16949**

**JAY ELECTRIC LIMITED**

Reviewed  
 Reviewed as noted  
 Resubmit

DATE: Feb. 25, 2015  
 REVIEWED BY: Gary R Beer

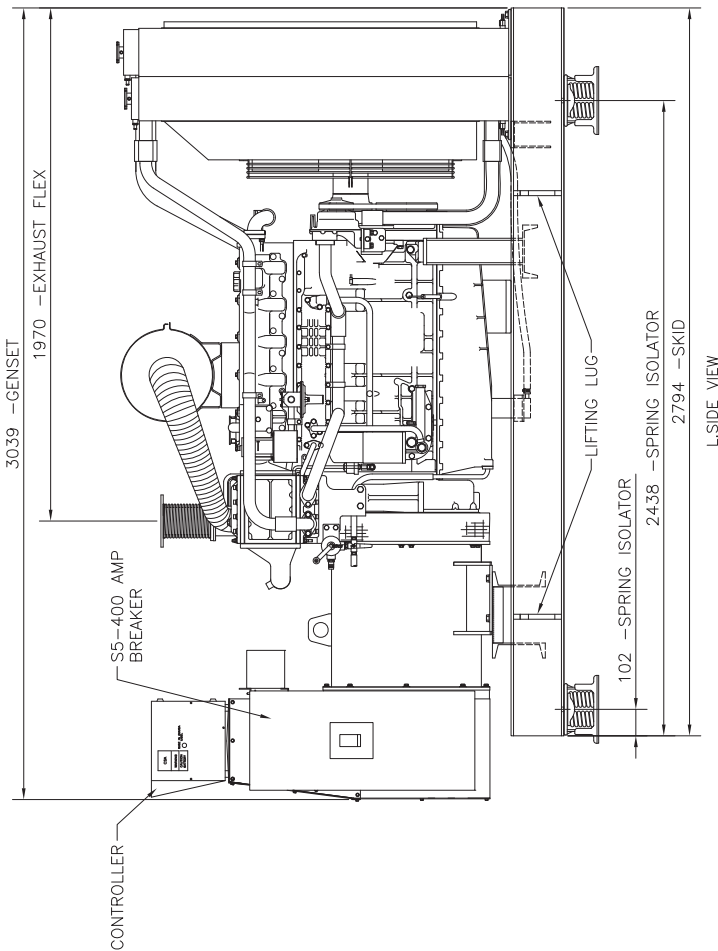
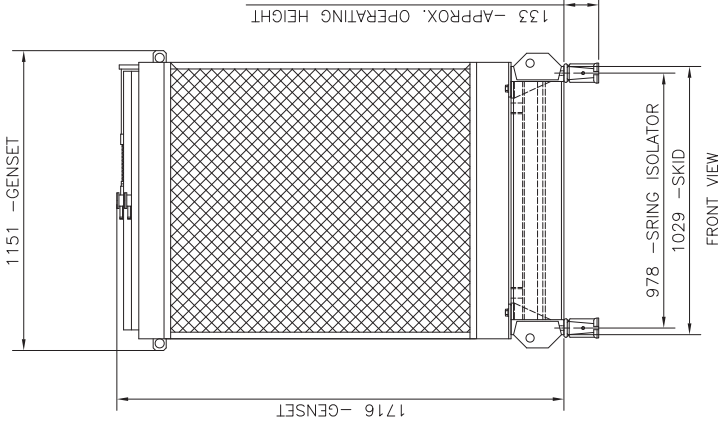

NOTE:  
 -DIMENSIONS ARE IN MILLIMETERS.  
 -WEIGHT: 4900 lbs.  
 -GAS CONSUMPTION: 3,000,000 BTU/HR.  
 -GAS PRESSURE AT ENGINE INLET: 18-20" WC

CUSTOMER	XXXXXXXXXXXXXXXXXX
DRAWN BY	LC
DATE	JUL 16/08
REV	NEW
DRAWING No.	NG200DWM-OPU
SHEET	1 OF 2

**NG200DWM  
 OPEN-UNIT**

**PARAMOUNT**  
 POWER SYSTEMS LTD.  
 MISSISSAUGA, ONTARIO  
 CANADA

No.	REVISONS	DATE	BY AUTH.
6	#5		
5	#4		
3	#3		
2	#2		
1	#1		
No.	No.		

NOTES

**JAY ELECTRIC LIMITED**

Reviewed  
 Reviewed as noted  
 Resubmit

DATE: Feb. 25, 2015  
 REVIEWED BY: Gary R Beer

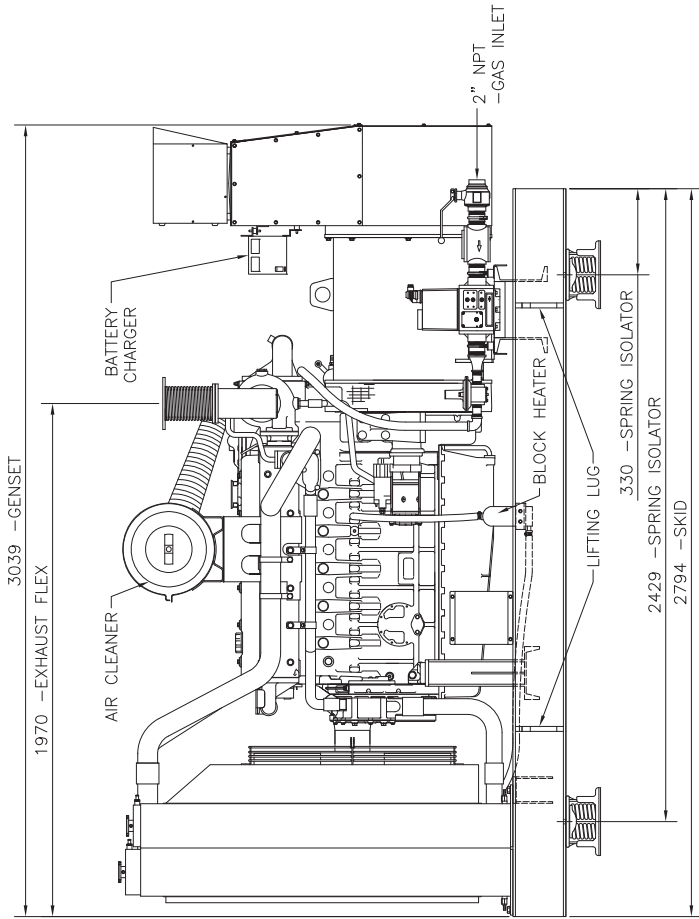

R.SIDE VIEW

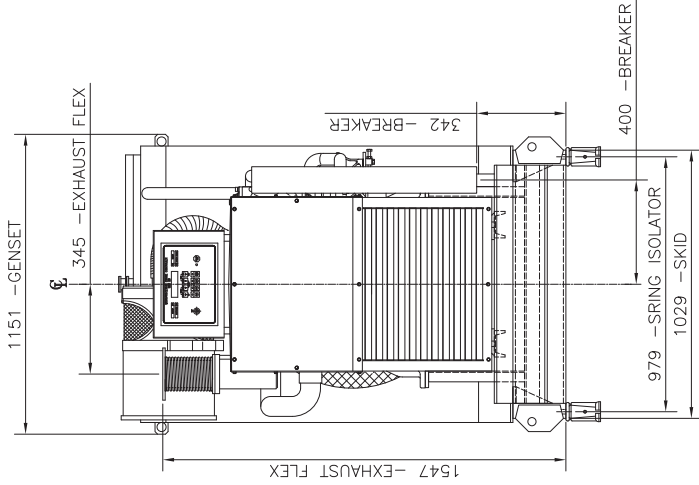

BACK VIEW

NOTE:  
 -DIMENSIONS ARE IN MILLIMETERS.  
 -WEIGHT: 4900 lbs.  
 -GAS CONSUMPTION: 3,000,000 BTU/HR.  
 -GAS PRESSURE AT ENGINE INLET: 18-20" WC

No.	REV	DATE	BY	AUTH	REVISIONS
6	#1				
5	#1				
3	#3				
2	#2				
1	#1				
NOTES					

CUSTOMER: XXXXXXXXXXXXXXXX	
DRAWN BY: LC	DATE: JUL 16/08
DRAWING No: XXX-XXX	SHEET: NEW
DRAWING No: NG200DWM-OPU	

  

<b>PARAMOUNT POWER SYSTEMS LTD.</b>	
MISSISSAUGA, ONTARIO	
CANADA	

  

<b>NG200DWM OPEN-UNIT</b>	
---------------------------	--

# UCS 200C [E1 ENCLOSURE]

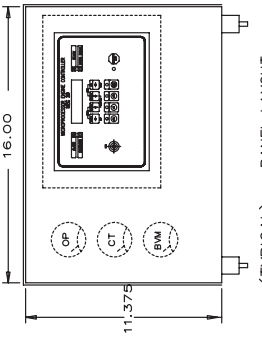
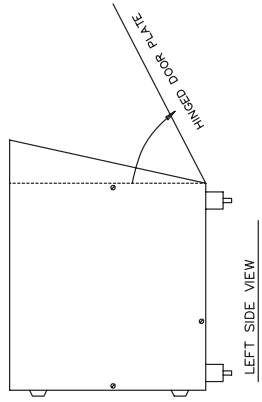

COLOUR: BLACK  
TYPE: EEMAC 1

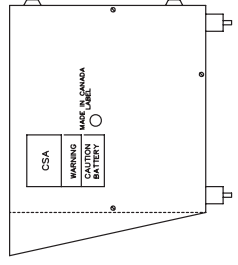
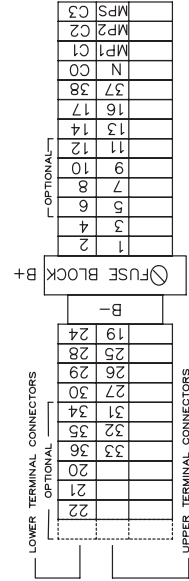
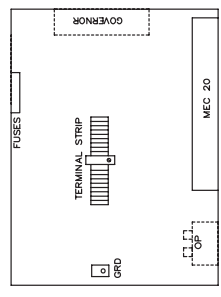
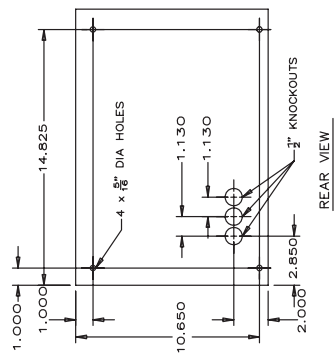
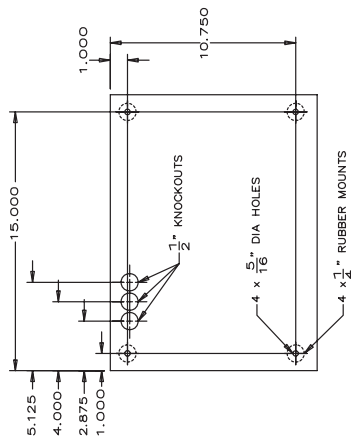

**JAY ELECTRIC LIMITED**  
 Reviewed  
 Reviewed as noted  
 Resubmit  
 DATE: Feb. 25, 2015  
 REVIEWED BY: Gary R. Beer

SYMBOL LEGEND

DC+	COMMON POSITIVE CONDUCTOR [ + ]
DC-	COMMON NEGATIVE CONDUCTOR [ - ]
⊖	COMMON CHASSIS GROUND
N	COMMON NEUTRAL CONDUCTOR
⊕	SAFETY EARTH GROUNDING CONDUCTOR
-	DASHED CONNECTIONS BY INSTALLER
-	CONTROL WIRE - TEW

SYSTEM CHARACTERISTICS

GENERATOR OUTPUT \_\_\_\_\_ KW  
 AC VOLTAGE \_\_\_\_\_ VAC  
 FREQUENCY \_\_\_\_\_ Hz  
 DC VOLTAGE \_\_\_\_\_ VDC  
 SYSTEM \_\_\_\_\_ PHASE

UCS 200C WIRING OPTIONS  
 NOTE: REFER TO MEC 20 PROGRAMMING SHEETS FOR SOFTWARE OPTIONS.

EXTRA DIGITAL FAULTS  
 011 [ ] Max-6  
 012 [ ] Max-3

EXTRA PROGRAMMABLE OUTPUTS  
 011 [ ]  
 012 [ ]  
 013 [ ]

IDLE CONTROL  
 ANALOG ENGINE GAUGES  
 ELECTRIC OP/CT  
 SWITCHGAUGE OP/CT  
 DC VOLTMETER  
 PANEL ILLUMINATION LIGHT

WIRE FOR GOVERNOR  
 BARBER COLEMAN DYNA 8000  
 BARBER COLEMAN DYNA 2500  
 WOODWARD 1712/1724  
 GAC 5500

BLOCK HEATER DISCONNECT RELAY  
 AIRFLAP OUTPUT  
 ENERGIZE TO STOP OUTPUT  
 PREHEAT OUTPUT

STANDARD CONSTRUCTION

1 TERMINAL DATA:  
 DC POSITIVE & NEGATIVE TERMINALS  
 ALL TERMINALS  
 MET-14 DOUBLE TERM. S.  
 1C - #20-PR, 2C - #14WG MAX.

2 10% SPARE TERMINALS PROVIDED.  
 WIRING DATA:  
 COLOUR CODE - PER DWG.  
 WIRE MARKERS - NONE  
 CRIMP CONNECTORS - NONE  
 WIRE TIE CONNECTORS - NONE  
 WTS: CCS-EPER CONTROL WIRE.

3 GROUND LUG: 1C - STUD 1/4x20 1/0 LUG

4 EXTERNAL LABELING:  
 WHITE LETTERS ON BLACK BACKGROUND  
 LABELS ARE MEANS OF IDENTIFICATION  
 SELF-ADHESIVE BACKING.

5 INTERNAL LABELING:  
 VINYL LABELS WITH INDELIBLE INK  
 PRINTING, MATCHING, LEAVE  
 UNCHANGED  
 LABELS ARE MEANS OF IDENTIFICATION  
 SELF-ADHESIVE BACKING.

APPROVED FOR CONSTRUCTION  
 MAKE COPY  
 MULTIPLE UNIT WORK ORDER  
 RELEASED FOR INFORMATION  
 AUTH. BY: \_\_\_\_\_ DATE: \_\_\_\_\_

PARAMOUNT POWER SYSTEMS LTD.  
 MISSISSAUGA, ONTARIO  
 CANADA

UCS200C  
 STANDARD CONTROL BOX  
 Layout and Dimensional Drawing

DRAWING No. UCS200C  
 SHEET 1 OF 1



# marathon™ Thomson Power Systems

Series TS 870 • 100 - 1200 Amp  
Bypass Isolation Transfer Switches



JAY ELECTRIC LIMITED	
<input checked="" type="checkbox"/>	Reviewed
<input type="checkbox"/>	Reviewed as noted
<input type="checkbox"/>	Resubmit
DATE	REVIEWED BY
Feb. 25, 2015	Gary R Beer

THOMSON

## OUTSTANDING FEATURES

### Enclosed Contact Power Switching Units

- **fully enclosed** silver alloy contacts provide **high withstand** rating & **100% continuous** current rating.
- barriers between the transfer switch and bypass isolation switch reduce the chance of consequential damage if there is a failure in either the transfer switch or bypass isolation switch.
- when isolated there is no power in the transfer switch compartment **providing true isolation**.
- **not damaged if manually switched** while in service since contacts have inherent spring over center design.

### Reliable Motor-Operated Transfer Mechanism

- **heavy duty** brushless gearmotor and operating mechanism provide mechanical interlocking and extreme long life with minimal maintenance.
- **safe manual operation** permits easy operation even under adverse conditions.
- all control wires and power busses are **front-accessible**, eliminating the cost and complexity of a drawout transfer switch.

### Control Features

- **TSC 80e** microprocessor based controller.
- **isolation plug** permits disconnecting control circuits from all power sources for safety and convenience.
- control circuitry permits complete **off load testing** of the transfer switch when isolated (a drawout transfer switch is not required.)

### Isolation Switch

- allows bypass without load interruption (double sided bypass only).

### Quality Assurance

- ISO 9001:2000 Registered

### Product Data

- Models from 100-1200 Amp continuous
- Available 3 or 4 pole
- All models 50/60Hz rated
- Voltage range 208-600V
- 3 phase, 3 or 4 wire systems

### Safety Standards

- CSA C22.2 No. 178/CSA C22.2 No. 31 (in accordance with **CSA 282-00** - Institutional & Residential Buildings Occupancy Group B and C)
- Seismic Certification – IBC 2405 - Section 13, Occupancy Category IV. ASCE7-05 Region 3 (minimum SS = 342%)



TS 870 - 400 AMP  
Bypass Isolation Transfer Switch

<b>JAY ELECTRIC LIMITED</b>	
<input checked="" type="checkbox"/> Reviewed	
<input type="checkbox"/> Reviewed as noted	
<input type="checkbox"/> Resubmit	
DATE	REVIEWED BY
Feb. 25, 2015	Gary R Beer

## GENERAL DESCRIPTION

The Thomson Power Systems TS 870 bypass isolation transfer switch includes all the features of the TS 870 transfer switch described in our TS 870 Automatic Transfer Switch brochure.

The TS 870 bypass isolation switch incorporates two basic types for bypass-isolation. Type "B" (double-sided) isolates the transfer switch and can bypass either the utility or generator source of the load, as selected by the operator. Single-sided bypass types "D" (utility bypass) and "C" (generator bypass) can bypass only one source to the load (in accordance with CSA 282-00 - Institutional & Residential Buildings Occupancy Group B and C). Note: CSA 282-00 requires (as a minimum) a single sided bypass on the generator supply.

The TS 870 series mechanisms utilize enclosed contact power switching units which provide a 100% continuous rating. The switches are mounted independently on a common frame.

Independent switching units provide a degree of reliability and redundancy not available with ganged contactor type bypass systems.

Each switching unit is equipped with an internal quick-make, quick-break mechanism as standard, and is certified to switch without de-energizing any system loads.

The single handle bypass mechanism is permanently mounted, and will not permit the sources to be interconnected. An operator has three simple steps to follow when bypassing, for servicing procedures or in cases when there is a transfer switch failure and manual transferring is required. The unique single handle bypass design allows bypassing with or without a load interruption (double-sided bypass only). Bypass and isolation position indication is permanently mounted at each switch position allowing the operator to clearly identify which mode the system is in (illuminated position indication is available as an option).

## STANDARD FEATURES (With TSC 80e Controller)

- LCD Display for monitoring 3 Phase Utility/Generator voltage, system frequency and timer countdown operation
- Front Panel Programming using built-in faceplate mounted pushbuttons & LCD display with password security
- Load on Utility & Load on Generator Lights
- Utility & Generator Source Available Lights
- 3 Phase Voltage sensing on Utility & Generator Sources
- Generator AC frequency sensing
- Utility under voltage control setpoint 70 - 95% (adjustable)
- Generator under voltage control setpoint 70 - 95% (adjustable)
- Generator under frequency control setpoint 70 - 90% (adjustable)
- Engine warm-up timer 0-60 sec. (adjustable)
- Utility return timer 0-30 min. (adjustable)
- Engine start timer 0-60 sec. (adjustable)
- Engine cooldown timer 0-30 min. (adjustable)
- Neutral position delay timer 0-60 sec. (adjustable)
- Load Disconnect Contact (LDC) for pre/post transfer control to signal external building systems such as elevators during transfer operations
- Programmable Generator Exercise Timer (EXT) with easy to use 4 event, 7-14-21-28 Day, on-load or off-load programmability
- Real-time clock c/w battery back-up & daylight-savings programming
- Data logging including total transfers to generator, total utility power failures, load on utility hours, load on generator hours and utility or generator voltage/ frequency data at time of fault
- Five user Programmable Output Contacts pre-wired to customer terminal blocks rated 10A, 120/240V resistive, Form C. Each output contact is user programmable to 10 different functions including: Load on Utility, Load on Gen, Load Disconnect Contact (LDC), Fail to Transfer (FTT), Utility Power Available (UPA), Generator Power Available (GPA), Utility Power Fail, Engine start,

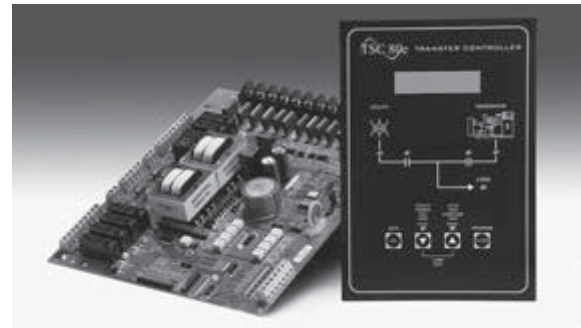

ATS Not in Auto, and ATS in Auto. The Transfer Switch is pre-programmed with the following outputs enabled:

- Load on Utility
- Load on Gen
- Load Disconnect Contact (LDC)
- Fail to Transfer (FTT)
- ATS Not in Auto
- Local utility power fail simulation test pushbutton & LED
- Remote utility power fail simulation test pushbutton input
- Local plant exercise initiate pushbutton & LED, door mounted
- Engine start contact (10A, 120/240VAC resistive max.)
- Transfer fail/forced transfer logic
- Automatic force transfer to alternate supply should load voltage become de-energized
- 50 or 60Hz capable (115V control power)
- Remote Load Test/Peak Shave Input
- NEMA 1 Enclosure
- Solid Neutral on 4 wire Systems

**JAY ELECTRIC LIMITED**

- Reviewed
- Reviewed as noted
- Resubmit

DATE: Feb. 25, 2015  
REVIEWED BY: Gary R Beer

# ONE-LINE SYSTEM DIAGRAM (Typical)

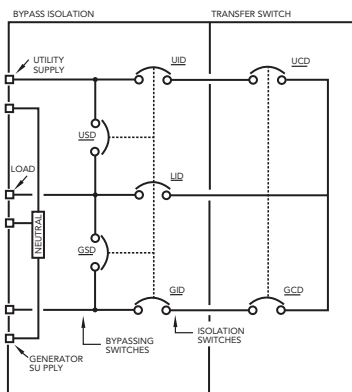

MODEL TS 870 - TYPE "D"

It is not possible to interconnect the utility and generator sources. No voltage is present at the transfer switch while isolated (i.e. isolation switches must all be open)

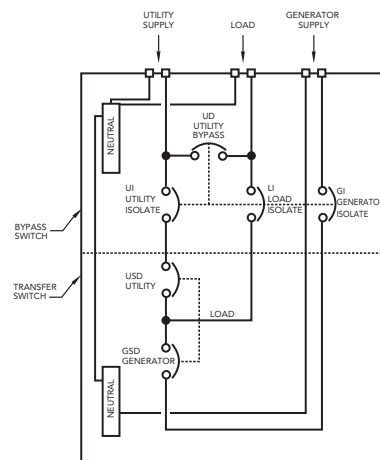

MODEL TS 870 - TYPE "B"

## WITHSTAND CURRENT RATINGS (ALL MODELS)

BASIC MODEL	MAXIMUM VOLTAGE	RATED CURRENT (AMPS)	WITHSTAND CURRENT RATING AMPS (RMS)				
			With Upstream Circuit Breaker Protection			With Upstream Fuse Protection	
			@240V	@480V	@600V	@ up to 600V	FUSE TYPE

TS 87xB - 0400	600	400	65,000	35,000	22,000	100,000	T,J
----------------	-----	-----	--------	--------	--------	---------	-----

## ENCLOSURE DIMENSIONS/CABLE TERMINALS (NEMA 1, ASA 61 GRAY)

SINGLE SIDED MODEL	DIMENSIONS (Inches) <sup>1</sup>						SHIPPING WT. (lbs)		TERMINAL RATING <sup>2</sup>	
	HEIGHT		WIDTH		DEPTH				QTY PER PHASE	RANGE <sup>3</sup>
	3 pole	4 pole	3 pole	4 pole	3 pole	4 pole	3 pole	4 pole		
TS 87xC(D) - 0100	54	54	34	34	16	16	350	355	1	#14 - 1/0
TS 87xC(D) - 0150	54	54	34	34	16	16	350	355	1	#2 - 4/0
TS 87xC(D) - 0200	54	54	34	34	16	16	360	440	1	#6 - 350 MCM
TS 87xC(D) - 0250	54	54	34	34	16	16	400	440	1	#6 - 350 MCM
TS 87xC(D) - 0400	64	84	41	41	15	15	565	610	2	2/0 - 250 MCM

<b>JAY ELECTRIC LIMITED</b>	
<input checked="" type="checkbox"/>	Reviewed
<input type="checkbox"/>	Reviewed as noted
<input type="checkbox"/>	Resubmit
DATE	REVIEWED BY
Feb. 25, 2015	Gary R Beer



**CONTROLLER FACTORY  
DEFAULT SETTINGS**

TIMER	DEFAULT	ZONE
ENGINE START	3	0-40Hz
ENGINE WARMUP	2	0-40Hz
ENGINE COOL	2	0-40Hz
ENGINE STOP	2	0-40Hz
RESTART TIMER	2	0-40Hz
NEUTRALIZER	3	0-40Hz
TRANSFER	30s	FIXED
FAULT TIMER	30s	FIXED
PROG. PROOF	0s	FIXED
UTL. TIMER	0s	FIXED
U/V TIMER	3s	FIXED
OPERATOR	3s	FIXED
UTILITY	3s	FIXED
U/V (PO)	60s	70-90%
GENERATOR	60s	70-90%
U/V (DO)	60s	70-90%
GENERATOR	60s	70-90%
U/V (PO)	60s	70-90%
OPERATOR	60s	70-90%

ALL SETTINGS ARE FIELD ADJUSTABLE UNLESS NOTED OTHERWISE IN THE TROUBLE MANUAL FOR A COMPLETE LIST OF ALL POSSIBLE SETTINGS.

**UTILITY SWITCHING DEVICE**

MOULDED CASE SWITCH   
 THERMAL MAGNETIC   
 ELECTRONIC (U)   
 ELECTRONIC (LSIG)   
 POLES 3   
 WITHSTAND RATING: 5kA @ 480V

**GENERATOR SWITCHING DEVICE**

MOULDED CASE SWITCH   
 THERMAL MAGNETIC   
 ELECTRONIC (U)   
 ELECTRONIC (LSIG)   
 POLES 3

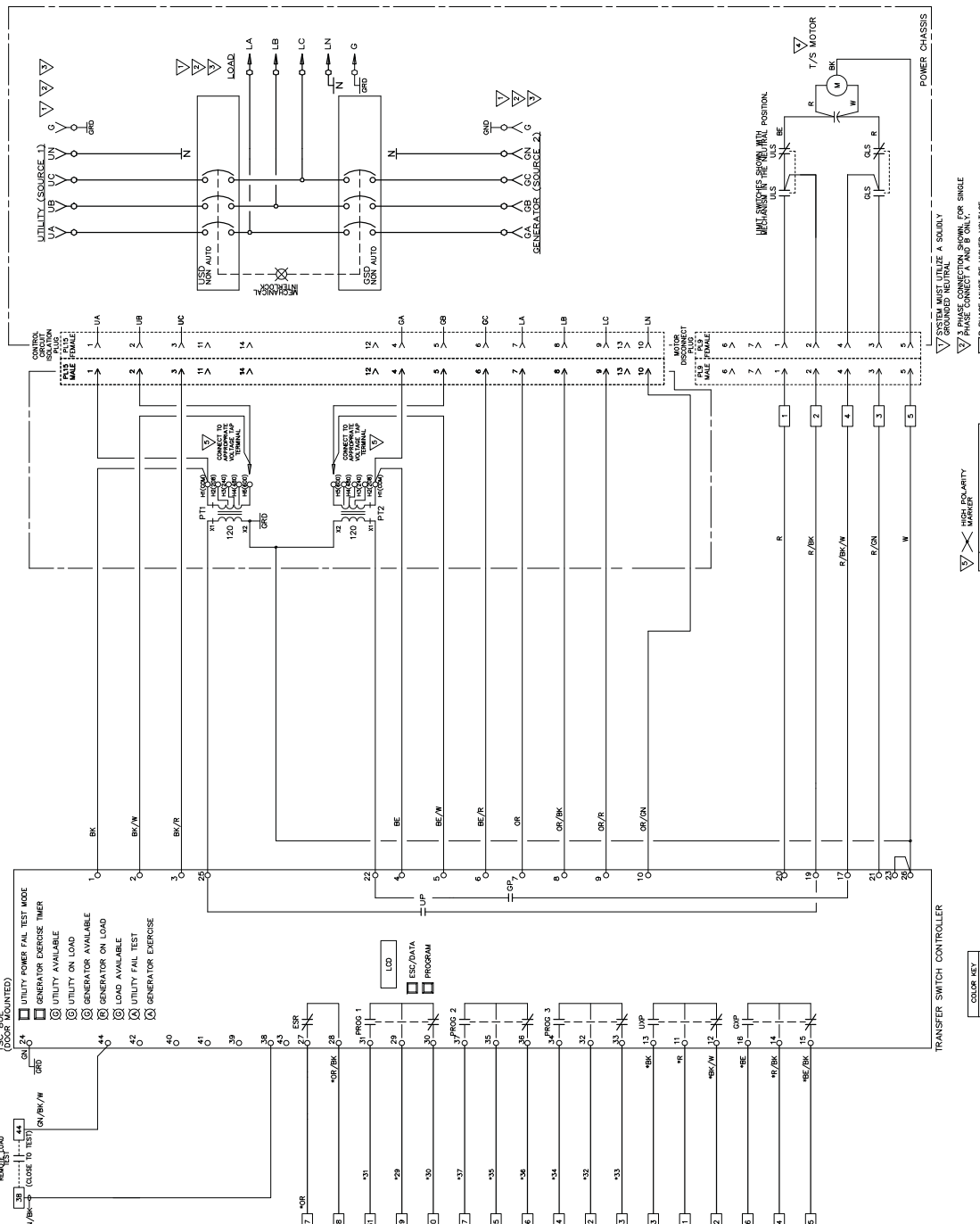

**TRANSFER SWITCH CONTROLLER**

Terminal	Signal / Description
1	ON/BK (CLOSE TO TEST)
2	ON/BK/W (CLOSE TO TEST)
3	ON/BK/W (DOOR MOUNTED)
4	UTILITY POWER FAIL TEST MODE
5	GENERATOR EXERCISE TIMER
6	UTILITY AVAILABLE
7	GENERATOR AVAILABLE
8	LOAD AVAILABLE
9	UTILITY FAIL TEST
10	GENERATOR EXERCISE
11	GEN START (NON-PROGRAMMABLE) ANALOGIC RES
12	LOAD ON (NON-PROGRAMMABLE) ANALOGIC RES
13	DISCON (NON-PROGRAMMABLE) ANALOGIC RES
14	UTL. CONTACT (NON-PROGRAMMABLE) ANALOGIC RES
15	GEN. CONTACT (NON-PROGRAMMABLE) ANALOGIC RES
16	ESC/DATA
17	PROGRAM
18	LOAD
19	PROG 1
20	PROG 2
21	PROG 3
22	UP
23	CP
24	ESR
25	ESR
26	ESR
27	ESR
28	ESR
29	ESR
30	ESR
31	ESR
32	ESR
33	ESR
34	ESR
35	ESR
36	ESR
37	ESR
38	ESR
39	ESR
40	ESR
41	ESR
42	ESR
43	ESR
44	ESR

**JAY ELECTRIC LIMITED**  
 Reviewed  
 Reviewed as noted  
 Resubmit  
 DATE: Feb. 25, 2015  
 REVIEWED BY: Gary R. Beer

## TRANSFER SWITCH CONTROLLER

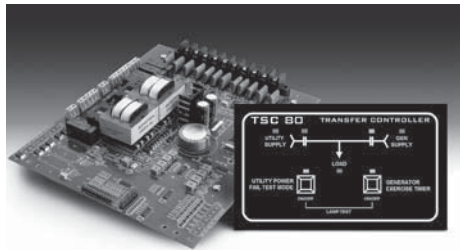

TSC 80

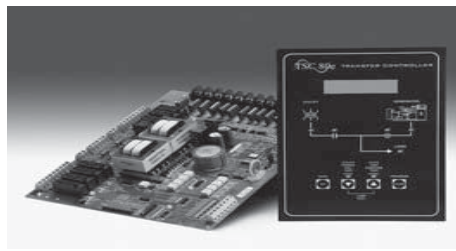

TSC 80e

- 2 models now available - standard TSC 80 or enhanced TSC 80e controller with additional features such as LCD display and programmable outputs
- Microprocessor-based circuitry provides ultimate reliability and versatility
- Non-volatile memory retains logic and setpoints if control power is lost
- Direct 3 phase voltage sensing inputs on generator and utility supplies from 120VAC up to 600VAC (nominal)
- Self diagnostic features continuously verify processing, I/O and memory circuits
- Simplified controller design is easy to use and requires no external software programming device
- Superior EMI/RFI noise immunity and voltage surge performance as per IEEE C62.41

### GENERAL DESCRIPTION

The Thomson Technology **TSC 80 / TSC 80e Transfer Switch Controller** utilizes the latest advancements in microprocessor technology, printed circuit board assembly and software for control of automatic transfer switches. The **TSC 80 / TSC 80e** is the second generation of microprocessor-based transfer switch controllers from Thomson Technology, and reflects over 30 years of transfer switch control experience. The **TSC 80 / TSC 80e** is factory configured to monitor, display and control all operational functions of the automatic transfer switch. All voltage sensors and timers are fully user adjustable utilizing potentiometers, which requires no software programming. The microprocessor design provides high accuracy for all voltage sensing and timing functions as well as providing many standard features.

The **TSC 80** Transfer Switch Controller is available in 2 basic model types - **TSC 80** Standard and **TSC 80e** Enhanced Transfer controller. The **TSC 80e** Enhanced Transfer Controller includes all of the features available in the standard **TSC 80** plus additional features such as LCD display, five programmable outputs, front programming buttons, data logging with real time clock, integrated Load Disconnect control and programmable exercise timer.

### TSC 80 STANDARD CONTROL FEATURES

- Utility & Generator AC voltage sensing (true RMS) – 120-600V single phase or 3 phase
- Generator AC frequency sensing
- Utility under voltage control setpoint 70 - 95% (adjustable)
- Generator under voltage control setpoint 70 - 95% (adjustable)
- Generator under frequency control setpoint 70 - 90% (adjustable)
- Engine warm-up timer 0-60 sec. (adjustable)
- Utility return timer 0-30 min. (adjustable)
- Engine start timer 0-60 sec. (adjustable)
- Engine cooldown timer 0-30 min. (adjustable)
- Neutral position delay timer 0-60 sec. (adjustable)
- Eight printed circuit board mounted user adjustable potentiometers
- Lamp Test
- Local utility power fail simulation test pushbutton & LED, door mounted
- Remote utility power fail simulation test pushbutton input (via terminal block)
- Load on utility supply & load on generator supply LED's, door mounted
- Utility and generator source available LED's, door mounted
- Weekly plant exercise timer (30 min. on load) manually initiated
- Local plant exercise initiate pushbutton & LED, door mounted
- Engine start contact (10A, 120/240VAC resistive max.)
- Load on utility auxiliary contact (Qty 1 only, 10A, 120/240VAC, Form C)
- Load on generator auxiliary contact (Qty 1 only, 10A, 120/240VAC, Form C)
- Transfer fail/forced transfer logic
- 50 or 60Hz capable (115V control power)

## TSC 80e STANDARD CONTROL FEATURES

- LCD Display for monitoring single or 3 Phase Utility/Generator voltage, system frequency and timer countdown operation
- Front Panel Programming using built-in faceplate mounted pushbuttons & LCD display with password security
- Utility & Generator AC Voltage sensing (true RMS) – 120-600V single or 3 phase
- Generator AC frequency sensing
- Utility under voltage control setpoint 70 - 95% (adjustable)
- Generator under voltage control setpoint 70 - 95% (adjustable)
- Generator under frequency control setpoint 70 - 90% (adjustable)
- Engine warm-up timer 0-60 sec. (adjustable)
- Utility return timer 0-30 min. (adjustable)
- Engine start timer 0-60 sec. (adjustable)
- Engine cooldown timer 0-30 min. (adjustable)
- Neutral position delay timer 0-60 sec. (adjustable)
- Pre/post transfer Load disconnect control to signal external building systems such as elevators during transfer operations
- Programmable Generator Exercise Timer (EXT) with easy to use 4 event, 7-14-21-28 Day, On-load or Off-load Programmability
- On Board Real-time clock c/w battery back-up & daylight-savings programming functionality
- Data logging of key events including total transfers to generator, total utility power failures, load on utility hours, load on generator hours and utility or generator voltage/ frequency data at time of fault
- Five user Programmable Output Contacts rated 10A, 120/240V resistive, Form C. Each output contact is individually user programmable to 10 different functions which includes: Load on Utility, Load on Gen, Load Disconnect Contact (LDC), Fail to Transfer (FTT), Utility Power Available (UPA), Generator Power Available (GPA), Utility Power Fail, Engine start, ATS Not in Auto, and ATS in Auto.  
The TSC 80e Controller is supplied pre-programmed from our factory with the following outputs enabled:
  - Load on Utility
  - Load on Generator
  - Load Disconnect Contact (LDC)
  - Fail to Transfer (FTT)
  - ATS Not in Auto
- Engine start contact (10A, 120/240VAC resistive max.)
- Local utility power fail simulation test pushbutton & LED, door mounted & remote test pushbutton input (via terminal block)
- Local plant exercise initiate pushbutton & LED, door mounted
- Load on Utility & Load on Generator LED Lights
- Utility & Generator Source Available LED Lights
- Lamp test
- Automatic force transfer to alternate supply should load voltage become de-energized
- 50 or 60Hz capable (115V control power)

## ADVANCED FEATURES

- 3 Phase voltage sensing on load bus, utility, and generator sources with direct input voltage up to 600VAC nominal
- Superior EMI/RFI noise immunity and voltage surge performance design features as per IEEE C62.41 requirements
- Complete 3 phase under voltage monitoring of both sources complete with user adjustable setpoints
- Automatic re-transfer to utility supply in test exercising modes should generator fail while on load
- Automatic plant exercise timer
- Automatic force transfer to alternate supply should load voltage become de-energized
- Flexible design allows user configuration to almost any system (i.e. 3 phase or single phase, system voltage, 50 or 60Hz system frequency)
- Remote Load Test/Peak Shave Input

## SPECIFICATIONS

- POWER SUPPLY:
  - 115VAC, -30%, +10%
  - 50/60Hz
  - 100ma nominal (no external load connected)
- VOLTAGE SENSING:
  - Direct 120-600VAC
  - 50/60Hz
  - +/- 1.0% accuracy of setting @ 25°C
- OPERATING TEMPERATURE:
  - -40°C to +50°C TSC 80
  - -15°C to +50°C TSC 80e
- OUTPUT CONTACTS (Form C 10A, 120/240VAC resistive)
- OUTPUT SIGNALS 120VAC
  - Transfer to utility 10A
  - Transfer to generator 10A

<b>JAY ELECTRIC LIMITED</b>	
<input checked="" type="checkbox"/> Reviewed	
<input type="checkbox"/> Reviewed as noted	
<input type="checkbox"/> Resubmit	
DATE	REVIEWED BY
Feb. 25, 2015	Gary R Beer

**NOTE:** Specifications subject to change without notice.  
CL 063 Rev 3 09/02/1 6520Z-SK-11/09-1500-RG

THOMSON TECHNOLOGY • 9087A - 198th STREET, LANGLEY, BC CANADA V1M 3B1

TELEPHONE: (604) 888-0110 • FAX: (604) 888-3381 • E-MAIL: info@thomsontechnology.com • www.thomsontechnology.com





# marathon™ Thomson Power Systems

Series TS 870 • 100 - 1200Amp

TS 870 Automatic Transfer Switches



<b>JAY ELECTRIC LIMITED</b>	
<input checked="" type="checkbox"/>	Reviewed
<input type="checkbox"/>	Reviewed as noted
<input type="checkbox"/>	Resubmit
DATE	REVIEWED BY
Feb. 25, 2015	Gary R Beer

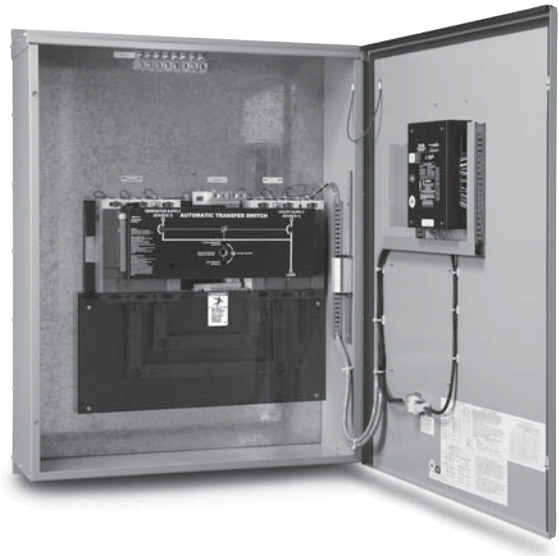

A Regal Brand

**REGAL**

# TS870 AUTOMATIC TRANSFER SWITCHES

THOMSON POWER SYSTEMS TS 870 AUTOMATIC TRANSFER SWITCHES OFFER THE FOLLOWING OUTSTANDING FEATURES:

## Enclosed Contact Power Switching Units

- Fully enclosed silver alloy contacts provide high withstand rating & 100% continuous current rating.
- 3 cycle short circuit current withstand.
- Completely isolated utility and generator side power switching units.
- Power switching units can incorporate over current protection, allowing cost savings in upstream devices.
- Not damaged if manually switched while in service.

## Reliable Motor-Operated Transfer Mechanism

- Heavy duty brushless gearmotor and operating mechanism provide mechanical interlocking and extreme long life.
- Safe manual operation permits operation under adverse conditions.

## Superior Serviceability

- All mechanical and control devices are visible and front accessible.
- All control wires and power busses are front-accessible.

## Control Features

- TSC 80e microprocessor based controller with integral front faceplate mounted LCD display and programmable outputs.
- Isolation plug permits disconnecting control circuits from all power sources.

## Quality Assurance

- ISO 9001 Registered

## Product Data

- Models from 100-1200 Amp continuous current
- Available 2, 3 or 4 pole
- All models 50/60Hz rated
- Voltage range 120-600VAC
- 3 phase, 3 or 4 wire systems

## Seismic Certification:

- TS 870 ATS is certified for installation and operation per the following requirements:
- IBC 2006 – Section 13, Occupancy Category IV
- ASCE7-05 Region 3 (minimum SS=342%)

## Safety Standards

- UL 1008 Automatic Transfer Switches for use in Emergency Systems
- CSA C22.2 No. 178 Automatic Transfer Switches

- \* Meets NFPA 110 for emergency and standby power systems.
- \* TSC80e controller is ROHS compliant.

<b>JAY ELECTRIC LIMITED</b>	
<input checked="" type="checkbox"/> Reviewed	
<input type="checkbox"/> Reviewed as noted	
<input type="checkbox"/> Resubmit	
DATE	REVIEWED BY
Feb. 25, 2015	Gary R Beer

## GENERAL DESCRIPTION

### STANDARD ATS

Thomson Power Systems **TS 870 Standard Automatic Transfer Switches** employ two mechanically interlocked power switching units with a microprocessor based controller to automatically start a generator and transfer system load to a generator supply in the event of a utility supply failure. System load is then automatically retransferred back to the utility supply following restoration of the utility power source to within normal operating limits. All load transfer sequences are "Open Transition" (i.e. "break-before make") with adjustable neutral position delay to ensure adequate voltage decay to prevent out of phase transfers.

**TS 870** Automatic Transfer Switches are certified to UL 1008 & CSA 178 Standards for use in Emergency Power System applications.

All **TS 870** transfer switches have been 3 cycle withstand current tested in accordance with UL 1008 & CSA 178.

The standard **TS 870** Automatic Transfer Switch is rated for 100% system load. The **TS 870** design allows optional use of integral over current trip elements within the power switching units.

All **TS 870** series transfer switches use a TSC 80e microprocessor based controller. All necessary control functions for fully automatic operation are provided by the TSC 80e transfer controller. The TSC 80e controller is mounted on the door of the transfer switch enclosure and operating status is shown via faceplate mounted LCD display and LED lights. All parameters and configuration is entered without opening the front doors.

Thomson **TS 870** Series ATS are also available in a Manually Initiated configuration without the TSC 80e controller but providing Source Availability and Position indication lights with a Source 1/Source 2 selector switch.

### SERVICE ENTRANCE ATS

Thomson Power Systems **TS 870 Service Entrance Automatic Transfer Switches** incorporate an isolating mechanism and over current protection on the utility supply thereby removing the need to have a separate, upstream circuit breaker/disconnect switch. This unique Service Entrance Rated Automatic Transfer Switch design is incorporated into a standard sized automatic transfer switch enclosure.

Standard features of the Service Entrance Rated Automatic Transfer Switch include a NEMA 1 rated enclosure, pad-lockable Service Disconnect control switch and status indications.

**TS 870 SE** Service disconnect operation ensures a high level of safety for system maintenance personnel. Normal operation and performance of the automatic transfer switch is unaffected by the Service Entrance ATS feature. The **TS 870 SE** Automatic Transfer Switch is rated for the system load and requires upstream over current protection on the generator supply.

The **TS 870 SE** series transfer switches use a type TSC 80e microprocessor based controller.

JAY ELECTRIC LIMITED	
<input checked="" type="checkbox"/> Reviewed	
<input type="checkbox"/> Reviewed as noted	
<input type="checkbox"/> Resubmit	
DATE	REVIEWED BY
Feb. 25, 2015	Gary R Beer

## WITHSTAND CURRENT RATINGS (ALL MODELS)

BASIC MODEL	MAXIMUM VOLTAGE	RATED CURRENT (AMPS)	WITHSTAND CURRENT RATING AMPS (RMS) <sup>1</sup>				
			With Upstream Circuit Breaker Protection			With Upstream Fuse Protection	
			@240V	@480V	@600V	@ up to 600V	FUSE TYPE
TS 87xA - 0400	600	400	65,000	50,000	35,000	100,000	T,J

<sup>1</sup> Note: For power switching devices equipped with optional overcurrent trip units, standard interrupting ratings are identical to withstand ratings shown at 240V and 480V. For interrupting ratings at 600V, contact Thomson Power Systems.

## ENCLOSURE DIMENSIONS/CABLE TERMINALS

(NEMA 1, ASA 61 GRAY)

BASIC MODEL	NUMBER OF POLES	DIMENSIONS Inches (mm) <sup>1</sup>			SHIPPING WEIGHT lbs (KG)	TERMINAL RATING <sup>3</sup>	
		HEIGHT	WIDTH	DEPTH		QTY PER PHASE	RANGE <sup>4</sup>
400A	2,3	43.1 (1095)	34.3 (871)	13.0 (330)	227 (103)	2	2/0 – 500 MCM

Optional NEMA 3R & 4X class enclosures available — consult Thomson Power Systems.  
For ATS with Distribution Breaker Option contact factory for dimensions.

<sup>1</sup> Enclosure dimensions are for reference. (DO NOT USE FOR CONSTRUCTION)

<sup>3</sup> All cable connections suitable for copper or aluminum

<sup>4</sup> Optional terminal ratings are available in some models – Consult Thomson Power Systems

<b>JAY ELECTRIC LIMITED</b>	
<input checked="" type="checkbox"/> Reviewed <input type="checkbox"/> Reviewed as noted <input type="checkbox"/> Resubmit	
DATE	REVIEWED BY
Feb. 25, 2015	Gary R Beer

## STANDARD FEATURES (With TSC 80e Controller)

- LCD Display for monitoring 3 Phase Utility/Generator voltage, system frequency and timer countdown operation
- Front Panel Programming using built-in faceplate mounted pushbuttons & LCD display with password security
- Load on Utility & Load on Generator Lights
- Utility & Generator Source Available Lights
- 3 Phase Voltage sensing on Utility & Generator Sources
- Generator AC frequency sensing
- Utility under voltage control setpoint 70 - 95% (adjustable)
- Generator under voltage control setpoint 70 - 95% (adjustable)
- Generator under frequency control setpoint 70 - 90% (adjustable)
- Engine warm-up timer 0-60 sec. (adjustable)
- Utility return timer 0-30 min. (adjustable)
- Engine start timer 0-60 sec. (adjustable)
- Engine cooldown timer 0-30 min. (adjustable)
- Neutral position delay timer 0-60 sec. (adjustable)
- Load Disconnect Contact (LDC) for pre/post transfer control to signal external building systems such as elevators during transfer operations
- Programmable Generator Exercise Timer (EXT) with easy to use 4 event, 7-14-21-28 Day, On-load or Off-load Programmability
- Real-time clock c/w battery back-up & daylight-savings programming
- Data logging including total transfers to generator, total utility power failures, load on utility hours, load on generator hours and utility or generator voltage/frequency data at time of fault
- Five user Programmable Output Contacts pre-wired to customer terminal blocks rated 10A, 120/240V resistive, Form C. Each output contact is user programmable to 10 different functions including: Load on Utility, Load on Gen, Load Disconnect Contact (LDC), Fail to Transfer (FTT), Utility Power Available (UPA), Generator Power Available (GPA), Utility Power Fail, Engine start, ATS Not in Auto, and ATS in Auto. The Transfer Switch is pre-programmed with the following outputs enabled:
  - Load on Utility
  - Load on Gen
  - Load Disconnect Contact (LDC)
  - Fail to Transfer (FTT)
  - ATS Not in Auto

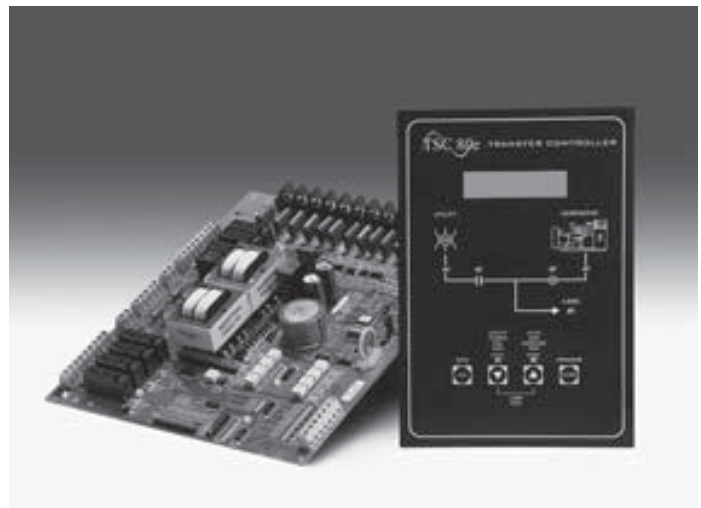

- Local utility power fail simulation test pushbutton & LED
- Remote utility power fail simulation test pushbutton input
- Local plant exercise initiate pushbutton & LED, door mounted
- Engine start contact (10A, 120/240VAC resistive max.)
- Transfer fail/forced transfer logic
- Automatic force transfer to alternate supply should load voltage become de-energized
- 50 or 60Hz capable (115V control power)
- Remote Load Test/Peak Shave Input
- NEMA 1 Enclosure
- Solid Neutral on 4 wire Systems

### JAY ELECTRIC LIMITED

- Reviewed
- Reviewed as noted
- Resubmit

DATE  
Feb. 25, 2015

REVIEWED BY  
*Gary R Beer*



**JAY ELECTRIC LIMITED**

Reviewed  
 Reviewed as noted  
 Resubmit

**DATE** Feb. 25, 2015 **REVIEWED BY** Sary R Beer

CONTROLLER FACTORY DEFAULT SETTINGS	
PARAMETER	DEFAULT RANGE / RANGE
ENGINE START TIMER	3 0-60sec
ENGINE STOP TIMER	2 0-60sec
ENGINE COOL DOWN TIMER	2 0-30min
UTILITY RETURN TIMER	2 0-30min
UTILITY TRANSFER	3 0-60sec
EXPOSURE	30min FIXED
UTIL. TIMER	0# FIXED
U/F TIMER	0# FIXED
U/V TIMER	3# FIXED
U/W TIMER	3# FIXED
U/X TIMER	3# FIXED
U/Y TIMER	3# FIXED
U/Z TIMER	3# FIXED
U/AA TIMER	3# FIXED
U/AB TIMER	3# FIXED
U/AC TIMER	3# FIXED
U/AD TIMER	3# FIXED
U/AE TIMER	3# FIXED
U/AF TIMER	3# FIXED
U/AG TIMER	3# FIXED
U/AH TIMER	3# FIXED
U/AI TIMER	3# FIXED
U/AJ TIMER	3# FIXED
U/AK TIMER	3# FIXED
U/AL TIMER	3# FIXED
U/AM TIMER	3# FIXED
U/AN TIMER	3# FIXED
U/AO TIMER	3# FIXED
U/AP TIMER	3# FIXED
U/AQ TIMER	3# FIXED
U/AR TIMER	3# FIXED
U/AS TIMER	3# FIXED
U/AT TIMER	3# FIXED
U/AU TIMER	3# FIXED
U/AV TIMER	3# FIXED
U/AW TIMER	3# FIXED
U/AX TIMER	3# FIXED
U/AY TIMER	3# FIXED
U/AZ TIMER	3# FIXED
U/BA TIMER	3# FIXED
U/BB TIMER	3# FIXED
U/BC TIMER	3# FIXED
U/BD TIMER	3# FIXED
U/BE TIMER	3# FIXED
U/BF TIMER	3# FIXED
U/BG TIMER	3# FIXED
U/BH TIMER	3# FIXED
U/BI TIMER	3# FIXED
U/BJ TIMER	3# FIXED
U/BK TIMER	3# FIXED
U/BL TIMER	3# FIXED
U/BM TIMER	3# FIXED
U/BN TIMER	3# FIXED
U/BO TIMER	3# FIXED
U/BP TIMER	3# FIXED
U/BQ TIMER	3# FIXED
U/BR TIMER	3# FIXED
U/BS TIMER	3# FIXED
U/BT TIMER	3# FIXED
U/BU TIMER	3# FIXED
U/BV TIMER	3# FIXED
U/BW TIMER	3# FIXED
U/BX TIMER	3# FIXED
U/BY TIMER	3# FIXED
U/BZ TIMER	3# FIXED
U/CA TIMER	3# FIXED
U/CB TIMER	3# FIXED
U/CC TIMER	3# FIXED
U/CD TIMER	3# FIXED
U/CE TIMER	3# FIXED
U/CF TIMER	3# FIXED
U/CG TIMER	3# FIXED
U/CH TIMER	3# FIXED
U/CI TIMER	3# FIXED
U/CL TIMER	3# FIXED
U/CM TIMER	3# FIXED
U/CN TIMER	3# FIXED
U/CO TIMER	3# FIXED
U/CP TIMER	3# FIXED
U/CQ TIMER	3# FIXED
U/CR TIMER	3# FIXED
U/CS TIMER	3# FIXED
U/CT TIMER	3# FIXED
U/CU TIMER	3# FIXED
U/CA	3# FIXED
U/CB	3# FIXED
U/CC	3# FIXED
U/CD	3# FIXED
U/CE	3# FIXED
U/CF	3# FIXED
U/CG	3# FIXED
U/CH	3# FIXED
U/CI	3# FIXED
U/CL	3# FIXED
U/CM	3# FIXED
U/CN	3# FIXED
U/CO	3# FIXED
U/CP	3# FIXED
U/CQ	3# FIXED
U/CR	3# FIXED
U/CS	3# FIXED
U/CT	3# FIXED
U/CU	3# FIXED
U/CA	3# FIXED
U/CB	3# FIXED
U/CC	3# FIXED
U/CD	3# FIXED
U/CE	3# FIXED
U/CF	3# FIXED
U/CG	3# FIXED
U/CH	3# FIXED
U/CI	3# FIXED
U/CL	3# FIXED
U/CM	3# FIXED
U/CN	3# FIXED
U/CO	3# FIXED
U/CP	3# FIXED
U/CQ	3# FIXED
U/CR	3# FIXED
U/CS	3# FIXED
U/CT	3# FIXED
U/CU	3# FIXED

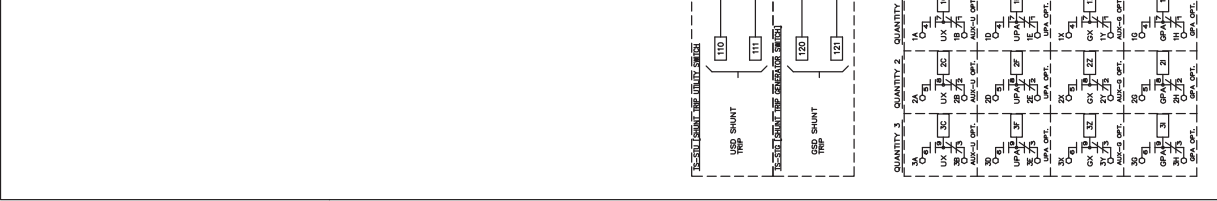
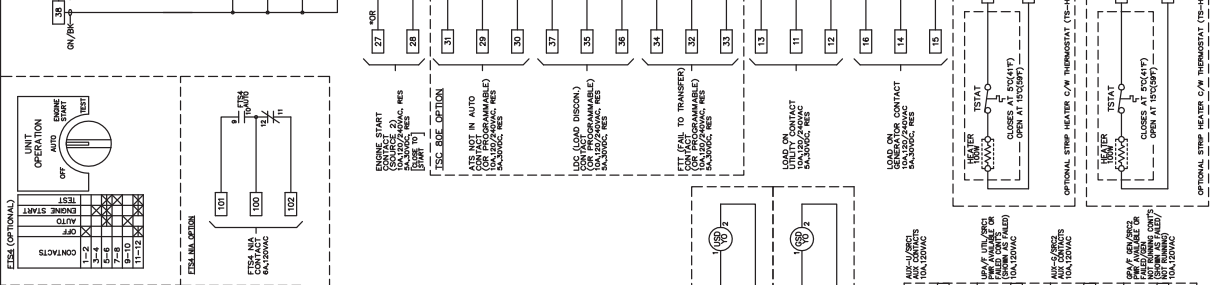
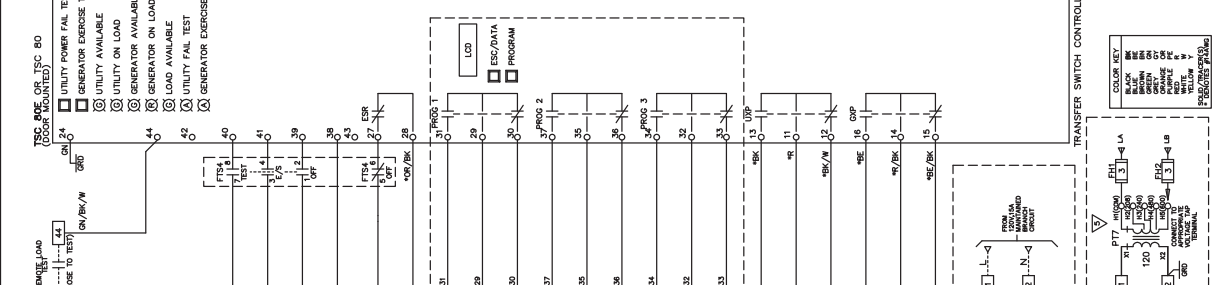
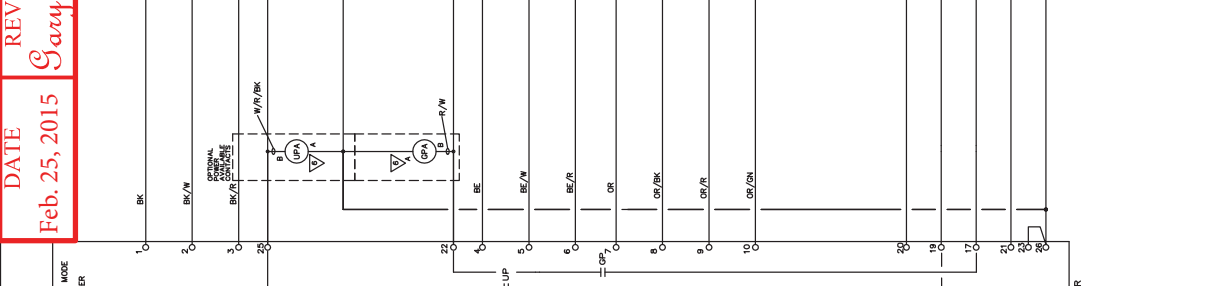
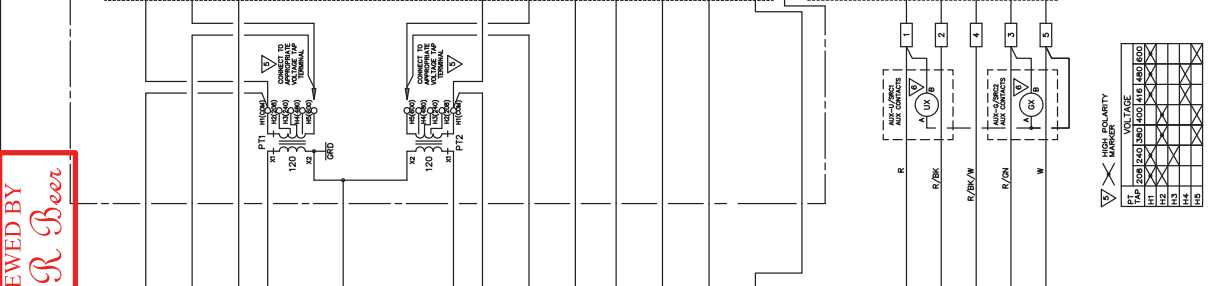
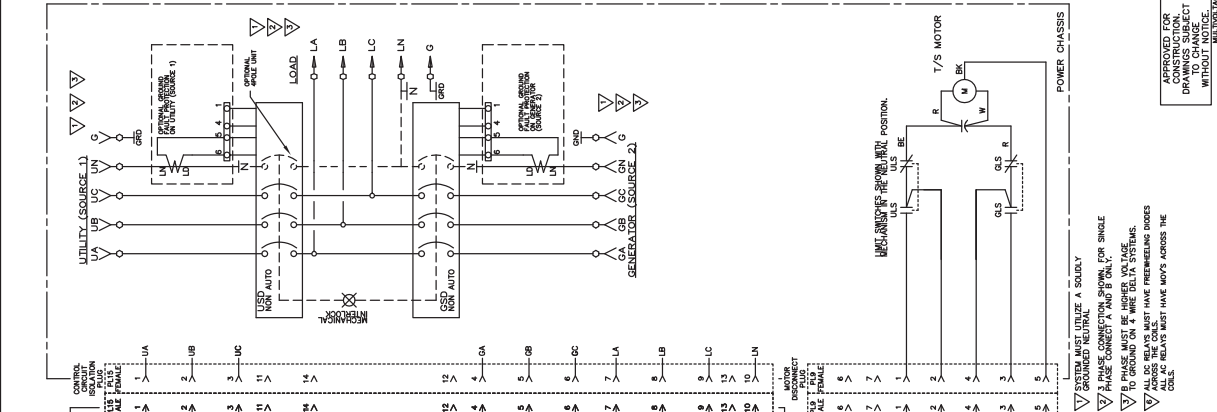

**APPROVED FOR CONSTRUCTION**  
 MASTER COPY  
 REFERENCE COPY  
 RELEASED FOR INFORMATION  
 AUTH: B.Y.O.G DATE: 07-06-26

**THOMSON TECHNOLOGY**  
 POWER ELECTRONICS COMPANY

**AUTOMATIC TRANSFER SWITCH**  
 MODEL TS 873A0400A1CN3AKKAA  
 SCHEMATIC DIAGRAM

400A, 600V, 3P, 4W, 60HZ

REVISIONS

No.	REVISIONS	DATE	BY/AUTH
01		08-10-14	PA/OS
02		08-10-14	BMG/OS
03		10-11-17	SM/OS
04		10-07-22	OS/OS
05		09-06-12	OS/OS

DRAWING NO. 07-06-26

APPROVED FOR CONSTRUCTION WITHOUT NOTICE